

# Non-Contact Pneumatic Sensors

## Reflex Sensors

### Reflex Sensor Type RML-4.8-S

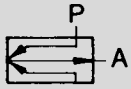

The reflex sensor is used as a non-contact signaling device. It is capable of sensing indicating instruments, monitoring press and stamping dies (sheet gauge, perforations, layering), including edge-guiding and magazine control, metering and measuring.

High pollution, noise interference, explosive atmosphere, total darkness or the transparency or magnetism of objects do not affect the functioning of reflex sensors.

The reflex sensor should be supplied with filtered, non-lubricated compressed air at port P. If the jet, constantly emitting air, is disturbed by an object in front of the sensor, a signal pressure  $\geq 0.0073$  psi / 0.5 mbar appears at outlet A. This signal pressure is then converted to a higher pressure by amplifiers.

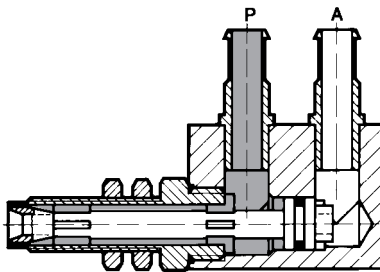
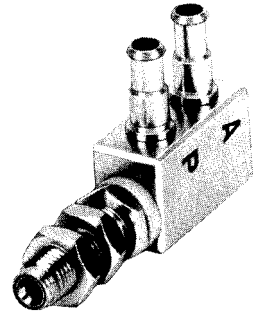

P = Supply  
A = Outlet

Order Number	Part No./Type	9849 RML-4.8-S
Medium		Compressed air (filtered, unlubricated)
Design		Reflex nozzle, no moving parts
Mounting		M6 x 0.75 with mounting nuts
Mounting Hole Diameter		0.24 in / 6.1 mm
Connection		Barbed fitting for 1/4 in / 4 mm plastic tubing
Supply Pressure Range of P*		1.13 to 3.75 psi / 0.075 to 0.25 bar
Signal Pressure Range, Max.		7.5 psi / 0.5 bar
Signal Pressure Range at A		See graph, next page
Air Consumption at 1.5 psi / 0.1 bar		0.5 scfm / 15 l/min
Materials		Housing: brass, Al. Seals: NBR
Weight		0.024 lb / 0.011 kg

\* 14 to 140°F / -10 to +60°C

### Type RML-4.8-S

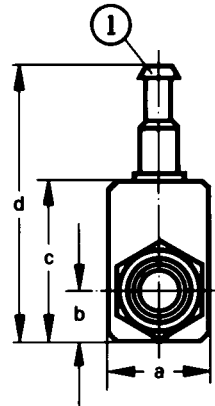
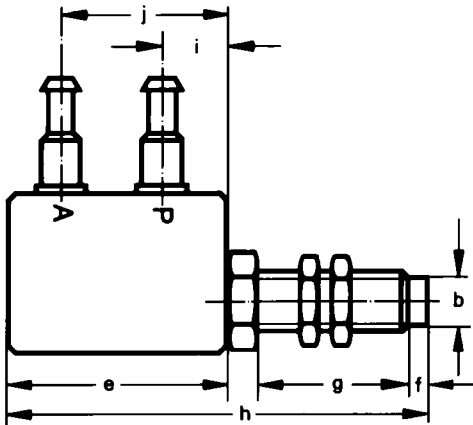

① Barbed fitting for 1/4 in / 4 mm plastic tubing

#### Dimensions

a 0.39 in / 10 mm	f 0.07 in / 2 mm
b 0.19 in / 5 mm	g 0.59 in / 15 mm
c 0.62 in / 16 mm	h 1.65 in / 42 mm
d 1.1 in / 27.5 mm	i 0.19 in / 6.5 mm
e 0.86 in / 22 mm	j 0.64 in / 16.5 mm

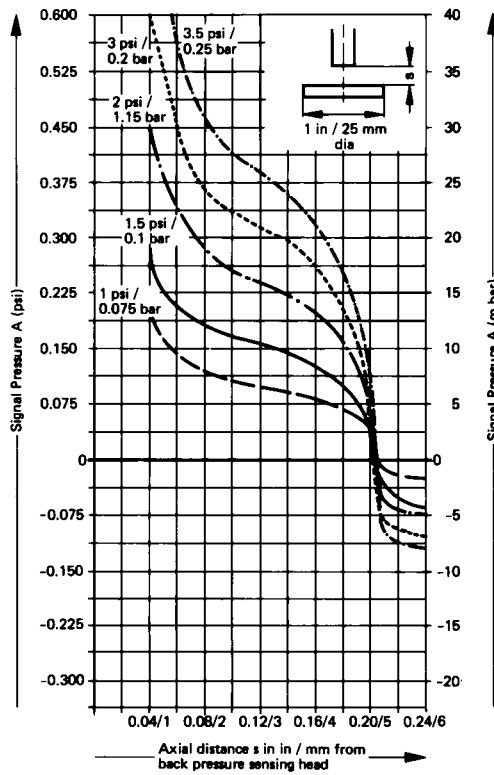

### Signal Pressure Versus Sensing Distance and Supply Pressure For Type RML-4.8-S

#### Axial Sensitivity at various pressures

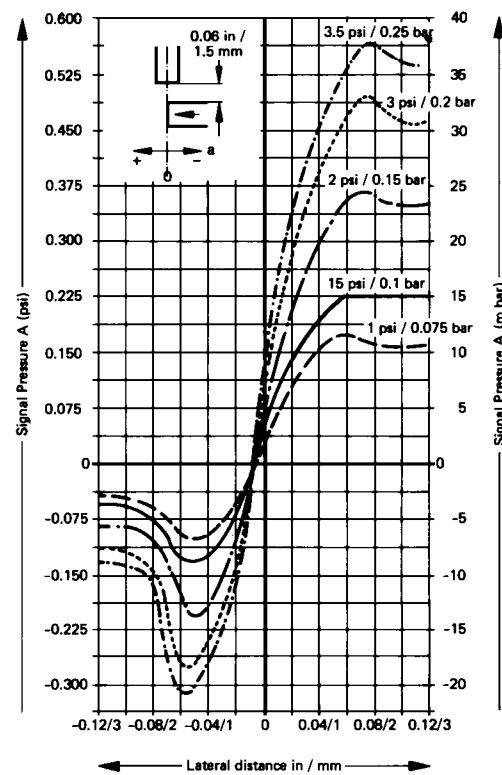

#### Lateral Sensitivity



Maximum sensing Distance	Minimum detectible variation	Minimum size of object to be detected (stationary pieces)		
0.19 to 0.21 in / 4.8 to 5.1 mm	0.002 in / 0.05 mm			
		0.15 x 0.10 in / 3.75 x 2.5 mm	0.12 x 0.12 in / 3 x 3 mm	0.12 in / 3 mm

# Non-Contact Pneumatic Sensors

## Reflex Proximity Sensors

### Reflex Sensor

Type RML-5

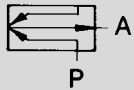

### Reflex Sensors

Type RFL-4

RFL-15

The reflex sensor is used as a non-contact signaling device. It is capable of sensing indicating instruments, monitoring press and stamping dies (sheet gauge, perforations, layering), including edge-guiding and magazine control, metering and measuring. Depending on the type used, a range covering 0.004 to 0.008 in / 0.1 to 0.2 mm can be detected.

High pollution, noise interference, explosive atmosphere, total darkness or the transparency or magnetism of objects do not affect the functioning of reflex sensors.

The reflex sensor should be supplied with compressed air at port P. The air with a pressure of 1.5 to 3 psi / 0.1 to 0.2 bar must be filtered and free of any water or oil. If the jet, constantly emitting air, is disturbed by an object in front of the sensor, a signal pressure  $\geq 0.007$  psi / 0.5 mbar appears at outlet A. This signal pressure is then converted to a higher pressure by amplifiers.

Type RML-5

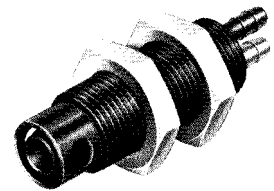

Type RFL-4

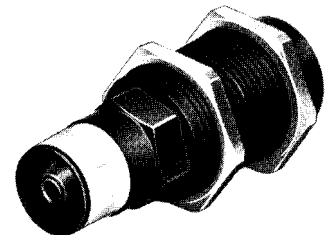

Type RFL-15

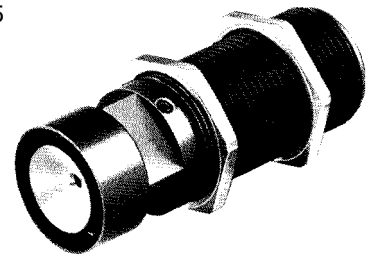

### Accessories:

Mounting Bracket, see page 199

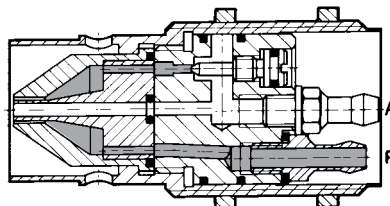

P = Supply  
A = Outlet

Order Number	Part No./Type	7050 RML-5	3649 RFL-4	7454 RFL-15
Medium		Compressed air (filtered, unlubricated)		
Mounting		M12 x 1 with mounting nuts	M22 x 1 with mounting nuts	
Mounting Hole Diameter		0.5 in / 12.5 mm	0.89 in / 22.5 mm	
Connection		Barbed fitting for 3/16 in / 3 mm tubing	Barbed fitting for 1/4 in / 4 mm tubing	
Supply Pressure Range at P*		1.5 to 3 psi / 0.1 to 0.2 bar		3 to 4.5 psi / 0.2 to 0.3 bar
Supply Pressure Range, Max.		7.5 psi / 0.5 bar		22.5 psi / 1.5 bar
Signal Pressure Range at A		See graph, page 233		
Air Consumption		See graph, page 233		
Ambient Temperature		-40 to 212°F / -40 to 100°C†		
Design		Back pressure nozzle, no moving parts		
Material		Brass	Al, brass	
Weight		0.055 lb / 0.025 kg	0.110 lb / 0.050 kg	0.187 lb / 0.085 kg

\* 14 to 140°F / -10 to 60°C

† Depending on tubing used

Type	Nozzle Diameter in / mm	Color Code	Max Sensing Range in / mm	Minimum Detectable Variation in Range in / mm	Minimum Size of Object to be Detected (Stationary Parts)		
					bxh in / mm	bxh in / mm	d in / mm
RML-5	—	None	0.22 / 5.5	0.008 / 0.2	0.12 x 0.4 / 3 x 10	0.32 x 0.4 / 8 x 10	0.14 / 3.5
RFL-4	0.084 / 2.25	Yellow	0.18 / 4.5	0.004 / 0.1	0.12 x 0.8 / 3 x 20	0.32 x 0.8 / 8 x 20	0.12 / 3
RFL-15	—	None	0.61 / 15.5	0.01 / 0.3	—	—	0.8 / 20

Type RML-5

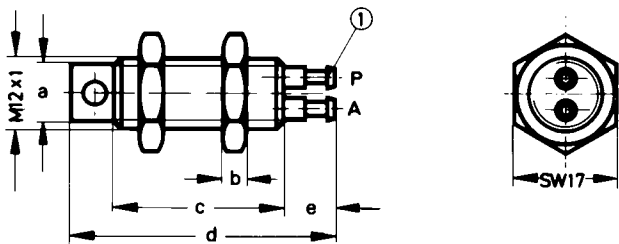

Type RFL-4

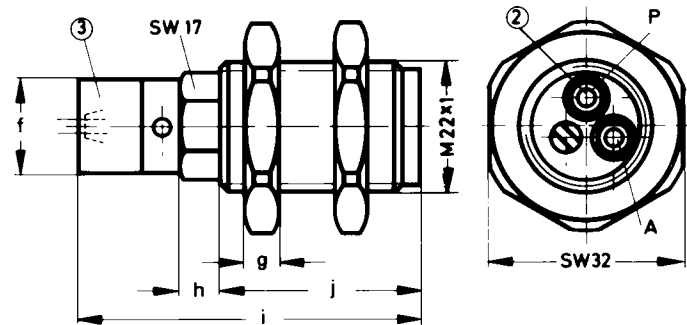

Type RFL-15

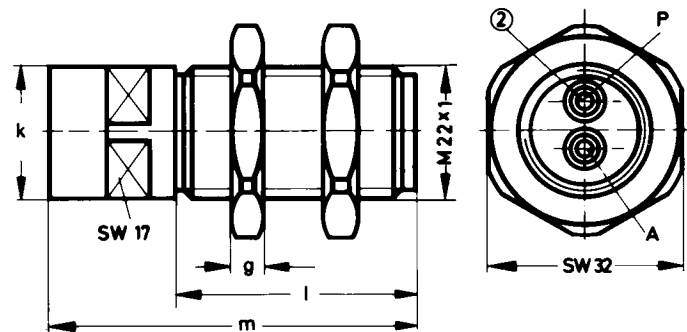

### Dimensions

- a 0.39 in / 10 mm
- b 0.16 in / 4 mm
- c 1.11 in / 28.3 mm
- d 1.77 in / 45 mm
- e 0.35 in / 9 mm
- f 0.63 in / 16 mm
- g 0.24 in / 6 mm
- h 0.29 in / 7.5 mm
- i 2.28 in / 58 mm
- j 1.32 in / 33.5 mm
- k 0.89 in / 22.5 mm
- l 1.58 in / 40 mm
- m 2.48 in / 63 mm

- ① Barbed fitting for 3/16 in / 3 mm tubing, connection P black, connection A yellow
- ② Barbed fitting for 1/4 in / 4 mm tubing
- ③ Color band

SW = wrench size, mm

# Non-Contact Pneumatic Sensors

## Reflex Proximity Sensors, Operating Characteristics

Signal Pressure Versus Supply Pressure and Nozzle Range For Types RML-5, RFL-4

Axial Sensitivity at 2.18 psi / 150 mbar Supply Pressure

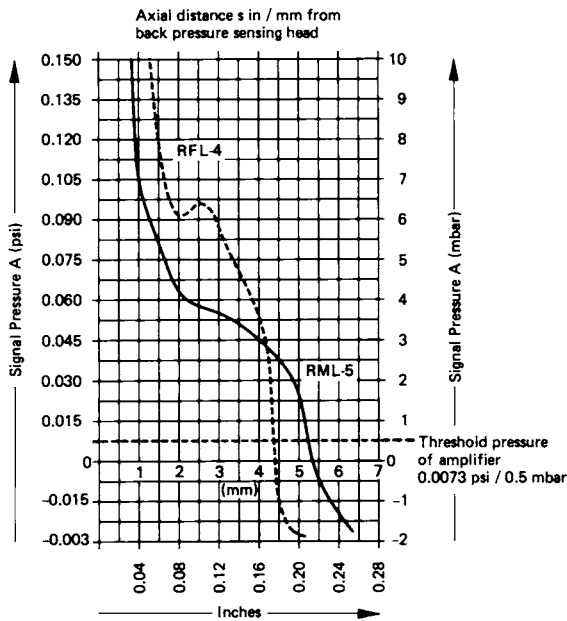

For Type RFL-15

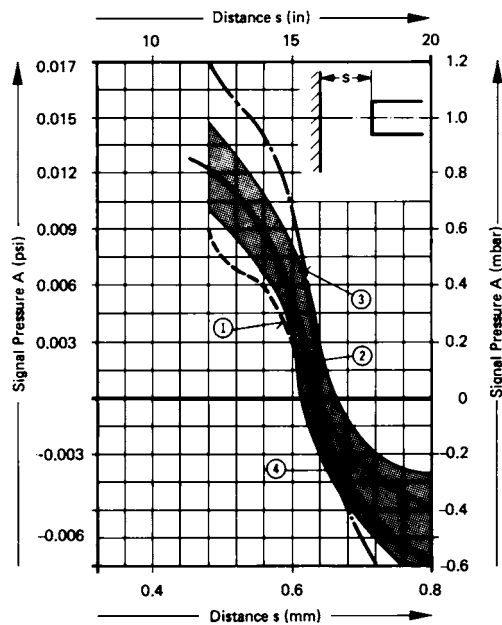

Lateral Sensitivity at 2.18 psi / 150 mbar Supply Pressure

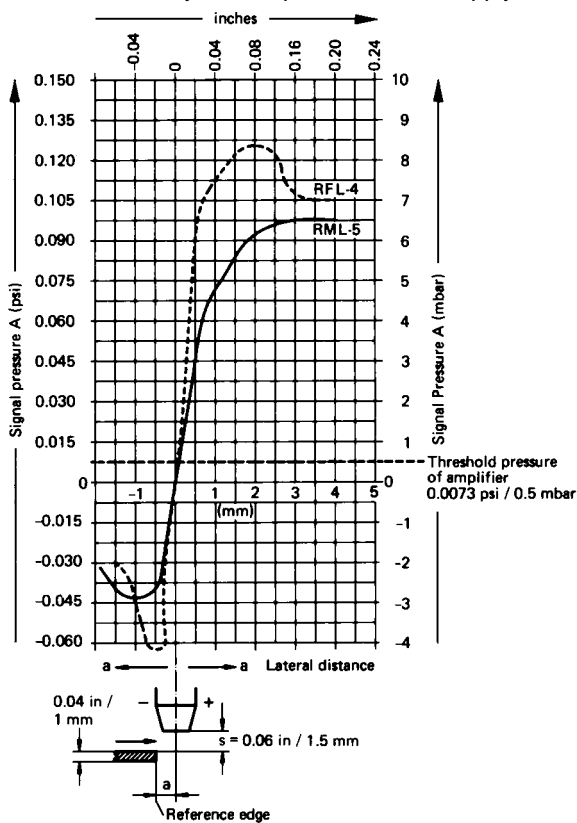

Air Consumption Versus Supply Pressure (Unrestricted Flow) For Types RML-5, RFL-4

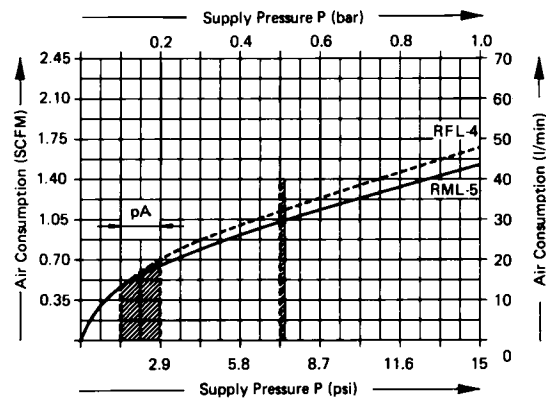

For Type RFL-15

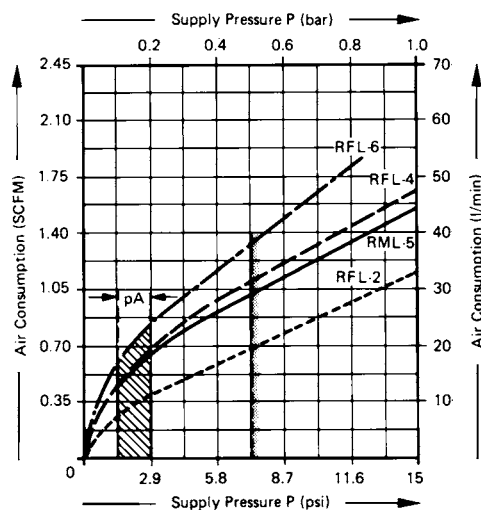

- ① Supply Pressure 2.18 psi / 150 mbar
- ② Supply Pressure 2.9 psi / 200 mbar
- ③ Supply Pressure 4.35 psi / 300 mbar
- ④ Sensing Range for Supply Pressure 2.9 psi / 200 mbar

Mounting Thread M12 x 1:  
 Foot Mount  
 Order No.  
 5123 HBN-8/10-1

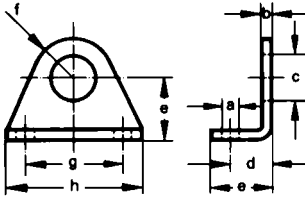

Flange Mount  
 Order No.  
 5129 FBN-8/10

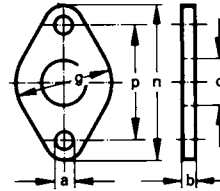

For Mounting Thread M22 x 1:  
 Foot Mount  
 Order No.  
 5127 HBN-20/25-1

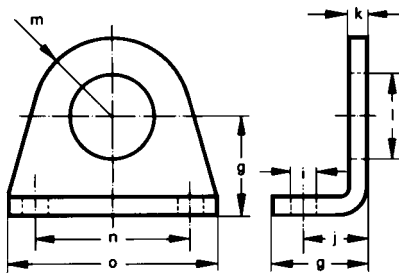

Flange Mount  
 Order No.  
 5131 FBN-20/25

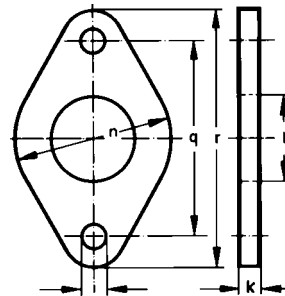

### Dimensions

a 0.18 in / 4.5 mm	j 0.67 in / 17 mm
b 0.12 in / 3 mm	k 0.20 in / 5 mm
c 0.48 in / 12.1 mm	l 0.87 in / 22.1 mm
d 0.43 in / 11 mm	m 0.79 in / 20 mm
e 0.63 in / 16 mm	n 1.58 in / 40 mm
f 0.39 in / 10 mm	o 2.13 in / 54 mm
g 0.99 in / 25 mm	p 1.18 in / 30 mm
h 1.38 in / 35 mm	q 1.97 in / 50 mm
i 0.26 in / 6.6 mm	r 2.60 in / 66 mm

# Festo - Your Partner in Automation



**1 Festo Inc.**  
5300 Explorer Drive  
Mississauga, ON L4W 5G4  
Canada

**Festo Customer Interaction Center**  
Tel: 1 877 463 3786  
Fax: 1 877 393 3786  
Email: [customer.service.ca@festo.com](mailto:customer.service.ca@festo.com)



**2 Festo Pneumatic**  
Av. Ceylán 3,  
Col. Tequesquináhuac  
54020 Tlalnepantla,  
Estado de México

**Multinational Contact Center**  
01 800 337 8669  
[ventas.mexico@festo.com](mailto:ventas.mexico@festo.com)



**3 Festo Corporation**  
1377 Motor Parkway  
Suite 310  
Islandia, NY 11749

**Festo Customer Interaction Center**  
1 800 993 3786  
1 800 963 3786  
[customer.service.us@festo.com](mailto:customer.service.us@festo.com)



**4 Regional Service Center**  
7777 Columbia Road  
Mason, OH 45040

Connect with us



[www.festo.com/socialmedia](http://www.festo.com/socialmedia)



[www.festo.com](http://www.festo.com)

Subject to change