

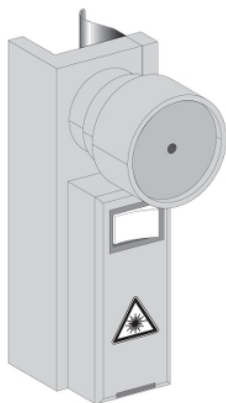

Product availability: Non-Stock - Not normally stocked in distribution facility



Main

Range of product	Preventa Safety detection
Accessory / separate part designation	Laser alignment tool
Accessory / separate part type	Laser
Accessory / separate part category	Installation accessories
Accessory / separate part destination	Safety light curtain type 4 Safety light curtain type 2

Complementary

Net weight	1.76 lb(US) (0.8 kg)
------------	----------------------

Ordering and shipping details

Category	22455 - LIGHT CURTAINS - XUSL
Discount Schedule	DS2
GTIN	00785901502586
Package weight(Lbs)	0.42 kg (0.93 lb(US))
Returnability	Yes
Country of origin	IT

Offer Sustainability

Sustainable offer status	Green Premium product
California proposition 65	WARNING: This product can expose you to chemicals including: Di-isodecyl phthalate (DIDP) and Diisononyl phthalate (DINP) which is known to the State of California to cause Carcinogen and Reproductive harm. For more information go to www.p65warnings.ca.gov
REACH Regulation	REACH Declaration
EU RoHS Directive	Pro-active compliance (Product out of EU RoHS legal scope) EU RoHS Declaration
Toxic heavy metal free	Yes
Mercury free	Yes
RoHS exemption information	Yes
Environmental Disclosure	Product Environmental Profile
Circularity Profile	End Of Life Information

The information provided in this documentation contains general descriptions and/or technical characteristics of the performance of the products contained herein. This documentation is not intended as a substitute for and is not to be used for determining suitability or reliability of these products for specific user applications. It is the duty of any such user or integrator to perform the appropriate and complete risk analysis, evaluation and testing of the products with respect to the relevant specific application or use thereof. Neither Schneider Electric Industries SAS nor any of its affiliates or subsidiaries shall be responsible or liable for misuse of the information contained herein.

Dimensions

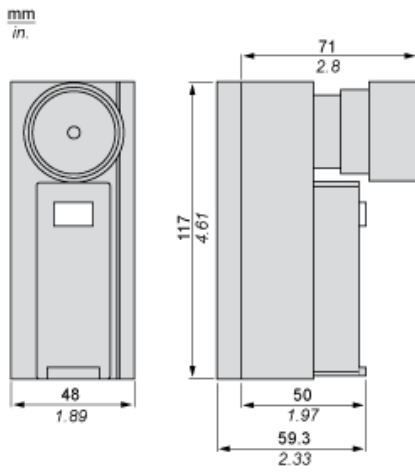

Mounting and Clearance

Laser Alignment Device

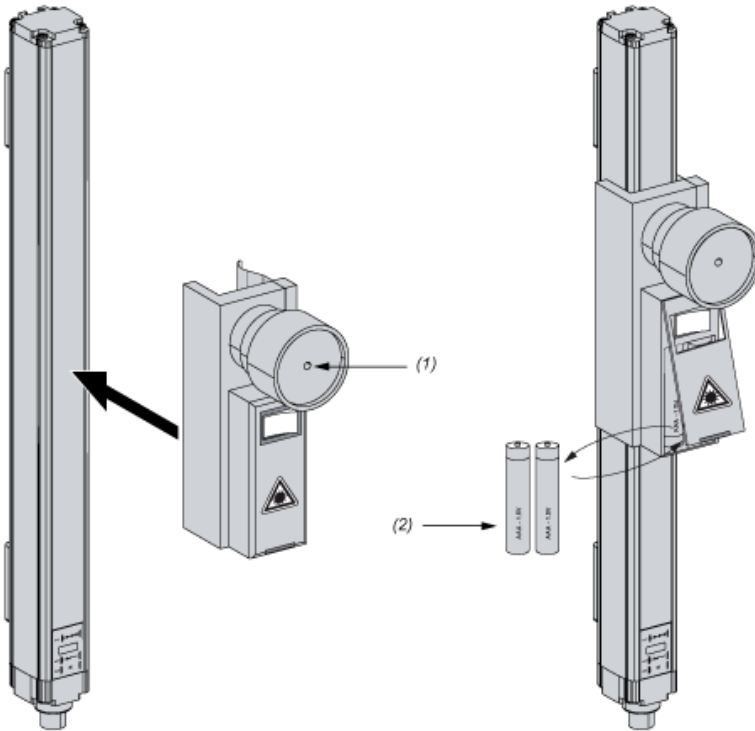

- (1) Position of the laser beam
- (2) 2 AAA batteries (not part of package)