



Product availability: Stock - Normally stocked in distribution facility



Main

Range compatibility	Lexium 28
Product or component type	Servo motor
Device short name	BCH2

Complementary

Maximum mechanical speed	3000 rpm
[Us] rated supply voltage	220 V
Phase	Three phase Single phase
Continuous stall current	5.77 A
Continuous stall torque	42.22 Lbf.In (4.77 N.m) LXM26D 7 A, 220 V, single phase 42.22 Lbf.In (4.77 N.m) LXM26D 7 A, 220 V, three phase 42.22 Lbf.In (4.77 N.m) LXM28... 7 A, 220 V, single phase 42.22 lbf.in (4.77 N.m) LXM28... 7 A, 220 V, three phase
Continuous power	1000 W
Peak stall torque	126.57 Lbf.In (14.3 N.m) LXM26D 7 A, 220 V, single phase 126.57 Lbf.In (14.3 N.m) LXM26D 7 A, 220 V, three phase 126.57 Lbf.In (14.3 N.m) LXM28... 7 A, 220 V, single phase 126.57 lbf.in (14.3 N.m) LXM28... 7 A, 220 V, three phase
Nominal output power	1000 W LXM26D 7 A, 220 V, single phase 1000 W LXM26D 7 A, 220 V, three phase 1000 W LXM28... 7 A, 220 V, single phase 1000 W LXM28... 7 A, 220 V, three phase
Nominal torque	42.22 Lbf.In (4.77 N.m) LXM26D 7 A, 220 V, single phase 42.22 Lbf.In (4.77 N.m) LXM26D 7 A, 220 V, three phase 42.22 Lbf.In (4.77 N.m) LXM28... 7 A, 220 V, single phase 42.22 lbf.in (4.77 N.m) LXM28... 7 A, 220 V, three phase
Nominal speed	2000 rpm LXM26D 7 A, 220 V, single phase 2000 rpm LXM26D 7 A, 220 V, three phase 2000 rpm LXM28... 7 A, 220 V, single phase 2000 rpm LXM28... 7 A, 220 V, three phase
Maximum current Irms	19.64 A LXM28... 1 kW, 220 V
Maximum permanent current	6.29 A
Product compatibility	LXM26D servo drive 1 kW, 220 V, single phase LXM26D servo drive 1 kW, 220 V, three phase LXM28... servo drive 1 kW, 220 V, single phase LXM28... servo drive 1 kW, 220 V, three phase
Shaft end	Keyed
Shaft diameter	0.87 in (22 mm)
Shaft length	2.17 in (55 mm)
Key width	0.31 in (8 mm)
Feedback type	20 bits single turn absolute encoder
Holding brake	Without
Mounting support	Asian standard flange

Motor flange size	5.12 in (130 mm)
Electrical connection	Connector MIL
Torque constant	0.83 N.m/A 68 °F (20 °C)
Back emf constant	50 V/krpm 68 °F (20 °C)
Rotor inertia	6.63 kg.cm ²
Stator resistance	0.62 Ohm 68 °F (20 °C)
Stator inductance	7.4 mH 68 °F (20 °C)
Stator electrical time constant	11.94 ms 68 °F (20 °C)
Maximum radial force Fr	670 N 2000 rpm
Maximum axial force Fa	200 N
Brake pull-in power	19.7 W
Type of cooling	Natural convection
Length	5.79 in (147 mm)
Number of motor stacks	1
Centring collar diameter	4.33 in (110 mm)
Centring collar depth	0.31 in (8 mm)
Number of mounting holes	4
Mounting holes diameter	0.36 in (9.2 mm)
Circle diameter of the mounting holes	5.71 in (145 mm)
Distance shaft shoulder-flange	0.31 in (8 mm)
Product weight	15.43 lb(US) (7 kg)

Environment

IP degree of protection	IP50 IM V3 IP65 IM B5, IM V1
Ambient air temperature for operation	-4...104 °F (-20...40 °C)

Ordering and shipping details

Category	18281 - LEXIUM 23/28 MOTORS
Discount Schedule	PC53
GTIN	00785901829430
Package weight(Lbs)	7.85 kg (17.3 lb(US))
Returnability	Yes
Country of origin	CN

Offer Sustainability

Sustainable offer status	Green Premium product
California proposition 65	WARNING: This product can expose you to chemicals including: Lead and lead compounds which is known to the State of California to cause Carcinogen & Reproductive harm. For more information go to www.p65warnings.ca.gov
REACH Regulation	REACH Declaration
REACH free of SVHC	Yes
EU RoHS Directive	Pro-active compliance (Product out of EU RoHS legal scope) EU RoHS Declaration
Mercury free	Yes
RoHS exemption information	Yes
China RoHS Regulation	China RoHS Declaration
Environmental Disclosure	Product Environmental Profile
Circularity Profile	No need of specific recycling operations
WEEE	The product must be disposed on European Union markets following specific waste collection and never end up in rubbish bins.

Dimensions

Dimensions of Motor

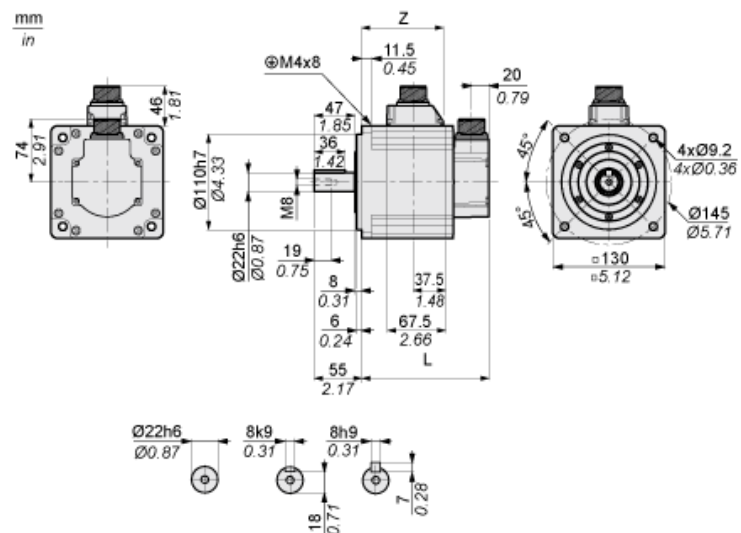

	mm	in.
L (without holding brake)	147	5.79
L (with holding brake)	183	7.2
Z	94.5	3.72

Torque/Speed Curves with 230 V Single/Three Phase Supply Voltage

Servo Motor with LXM28AU10●●● Servo Drive

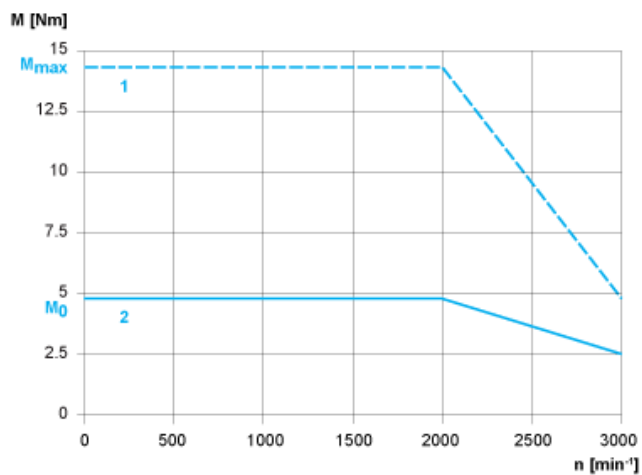

- 1 : Peak torque
- 2 : Continuous torque