

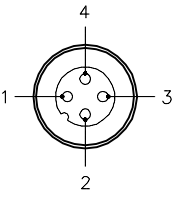

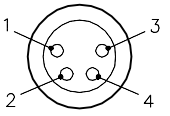

MALE END VIEW	FEMALE END VIEW	WIRING DIAGRAM	SPECIFICATIONS																	
			<table border="1"> <tr><td>CONTACT CARRIER MATERIAL</td><td>NYLON OR TPU</td></tr> <tr><td>MOLDED HEAD MATERIAL/COLOR</td><td>TPU/YELLOW</td></tr> <tr><td>CONTACT MATERIAL/PLATING</td><td>BRASS/GOLD</td></tr> <tr><td>COUPLING NUT MATERIAL/PLATING</td><td>BRASS/NICKEL</td></tr> <tr><td>RATED CURRENT [A]</td><td>4.0 A</td></tr> <tr><td>RATED VOLTAGE [V]</td><td>60 VAC/75 VDC</td></tr> <tr><td>TEMPERATURE RANGE</td><td>-40°C to +105°C (-40°F to +221°F)</td></tr> <tr><td>PROTECTION CLASS</td><td>MEETS NEMA 1,3,4,6P AND IEC IP67</td></tr> </table>	CONTACT CARRIER MATERIAL	NYLON OR TPU	MOLDED HEAD MATERIAL/COLOR	TPU/YELLOW	CONTACT MATERIAL/PLATING	BRASS/GOLD	COUPLING NUT MATERIAL/PLATING	BRASS/NICKEL	RATED CURRENT [A]	4.0 A	RATED VOLTAGE [V]	60 VAC/75 VDC	TEMPERATURE RANGE	-40°C to +105°C (-40°F to +221°F)	PROTECTION CLASS	MEETS NEMA 1,3,4,6P AND IEC IP67	
CONTACT CARRIER MATERIAL	NYLON OR TPU																			
MOLDED HEAD MATERIAL/COLOR	TPU/YELLOW																			
CONTACT MATERIAL/PLATING	BRASS/GOLD																			
COUPLING NUT MATERIAL/PLATING	BRASS/NICKEL																			
RATED CURRENT [A]	4.0 A																			
RATED VOLTAGE [V]	60 VAC/75 VDC																			
TEMPERATURE RANGE	-40°C to +105°C (-40°F to +221°F)																			
PROTECTION CLASS	MEETS NEMA 1,3,4,6P AND IEC IP67																			
																				

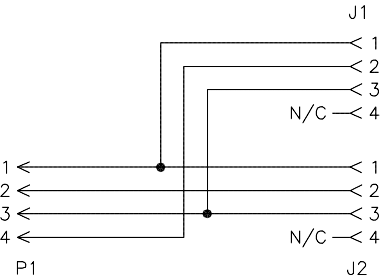

SOURCE DRAWING - FOR REFERENCE ONLY

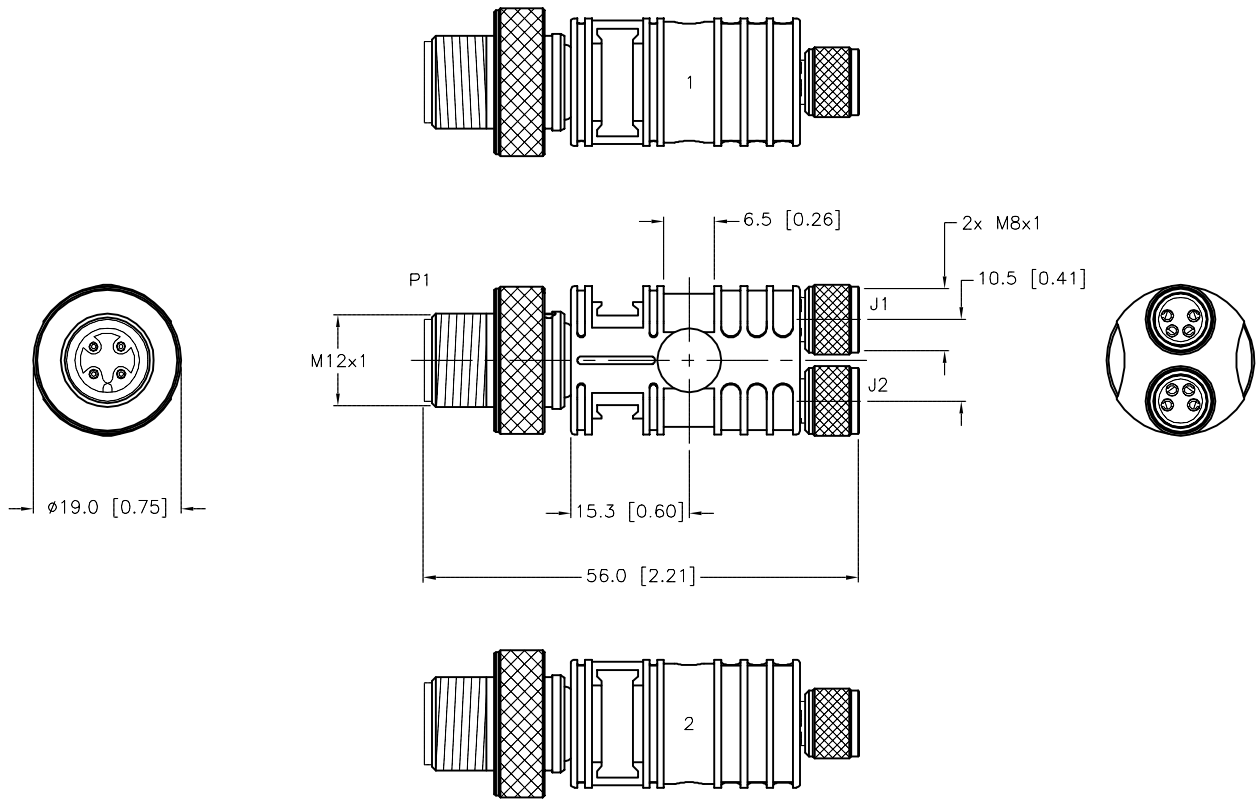
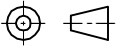
RELATED DOCUMENTS 1. 2. 3. 4.	3RD ANGLE PROJECTION 	THIS DRAWING IS CONFIDENTIAL AND THE PROPERTY OF TURCK INC. USE OF THIS DOCUMENT WITHOUT WRITTEN PERMISSION IS PROHIBITED.	<div style="text-align: right;"> <p>3000 CAMPUS DRIVE          MINNEAPOLIS, MN 55441          1-800-544-7769          (763) 553-7300          (763) 553-0708 fax          www.turck.us</p> </div> <div style="text-align: center;">  </div>
MATERIAL  SEE SPECIFICATIONS  FINISH  SEE SPECIFICATIONS	ALL DIMENSIONS DISPLAYED ON THIS DRAWING ARE FOR REFERENCE ONLY  CONTACT TURCK FOR MORE INFORMATION	DRFT RDS DATE 02/17/04 APVD SCALE 1=1.0 UNIT OF MEASUREMENT <b>MILLIMETER [ INCH ]</b>	DESCRIPTION VBRS 4.4-2SKM 4  IDENTIFICATION NO. U0961-00 REV C
C DRAWING PROCESSED AS PART OF ECO 33971 REV DESCRIPTION	CBM 04/07/11 BY DATE	33971 ECO NO.	DO NOT SCALE THIS DRAWING FILE: U0961-00 SHEET 1 OF 1