

# UC-8200 Series

*Arm Cortex-A7 dual-core 1 GHz IIoT gateway with built-in LTE Cat. 4, 1 mini PCIe expansion slot for a Wi-Fi module, 1 CAN port, 4 DIs, 4 DOs*



## Features and Benefits

- Armv7 Cortex-A7 dual-core 1 GHz
- Moxa Industrial Linux with 10-year superior long-term support
- 2 auto-sensing 10/100/1000 Mbps Ethernet ports
- Integrated LTE Cat. 4 module with US/EU/APAC band support
- Dual-SIM slots
- Integrated isolation of the DI and CAN interfaces and the antenna ports for insulation protection against external electrical interference
- 1 CAN port supports CAN 2.0A/B
- microSD socket for storage expansion
- Programmable LEDs and a programmable button for easy installation and maintenance
- -40 to 85°C wide temperature range and -40 to 70°C with LTE enabled

## Certifications



## Introduction

The UC-8200 computing platform is designed for embedded data acquisition applications. The computer comes with dual RS-232/422/485 serial ports, dual 10/100/1000 Mbps Ethernet ports, and one CAN port as well as dual Mini PCIe socket to support Wi-Fi/cellular modules. These versatile capabilities let users efficiently adapt the UC-8200 to a variety of complex communications solutions.

The UC-8200 is built around a Cortex-A7 dual core processor that has been optimized for use in energy monitoring systems, but is widely applicable to a variety of industrial solutions. With flexible interfacing options, this tiny embedded computer is a reliable and secure gateway for data acquisition and processing at field sites as well as a useful communications platform for many other large-scale deployments.

Wide temperature LTE-enabled models are available for extended temperature applications. All units are thoroughly tested in a testing chamber, guaranteeing that the LTE-enabled computing platforms are suitable for wide-temperature applications.

## Appearance

### UC-8210

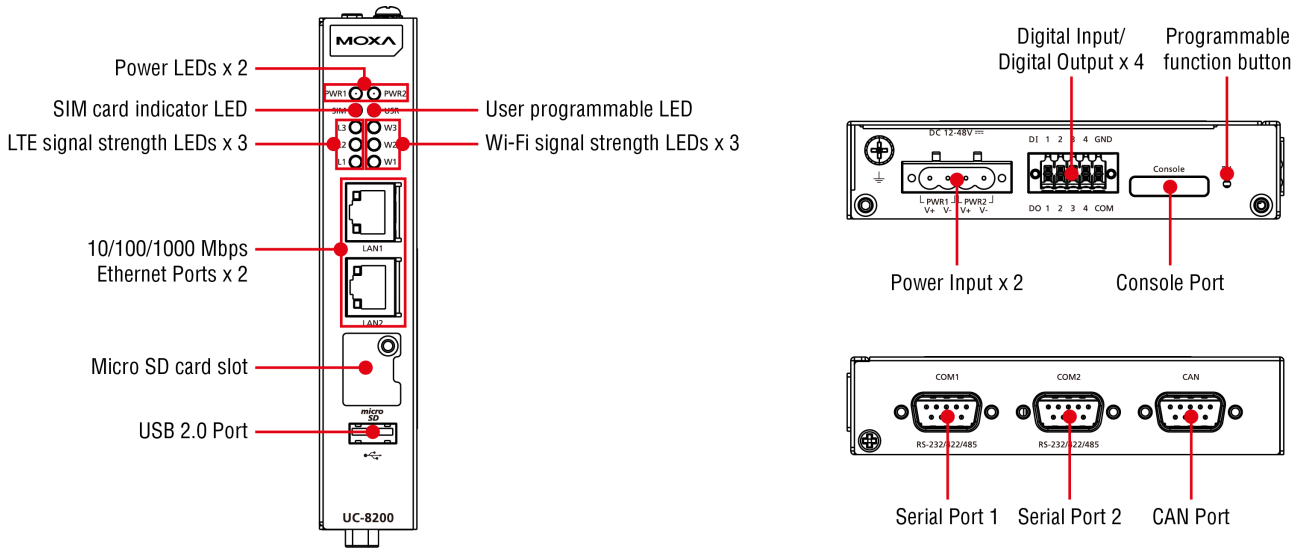

### UC-8220

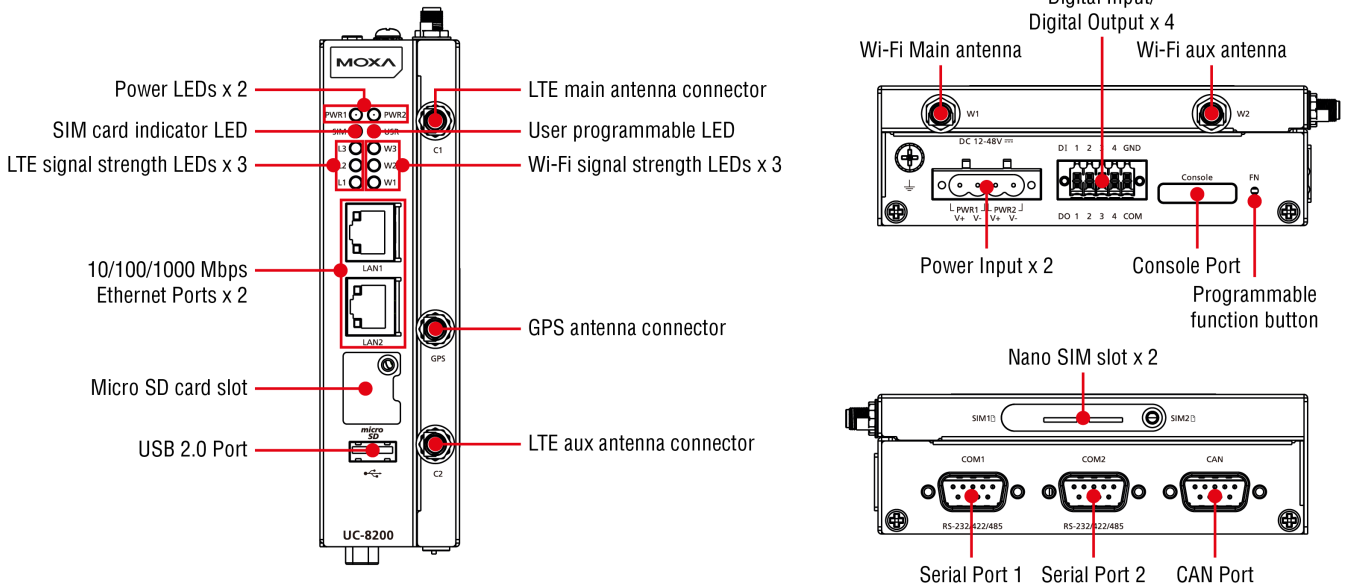

## Specifications

### Computer

CPU	Armv7 Cortex-A7 dual-core 1 GHz
DRAM	2 GB DDR3L
Storage Pre-installed	8 GB eMMC
Pre-installed OS	Moxa Industrial Linux (Debian 9, Kernel 4.4)
Expansion Slots	MicroSD (SD 3.0) socket x 1

## Computer Interface

TPM	UC-8210-T-LX-S: TPM v2.0 UC-8220-T-LX-AP-S: TPM v2.0 UC-8220-T-LX-EU-S: TPM v2.0 UC-8220-T-LX-US-S: TPM v2.0
Ethernet Ports	Auto-sensing 10/100/1000 Mbps ports (RJ45 connector) x 2
Serial Ports	RS-232/422/485 ports x 2, software selectable (DB9 male)
CAN Ports	CAN 2.0 A/B x 1 (DB9 male)
Digital Input	DIs x 4
Digital Output	DOs x 4
USB 2.0	USB 2.0 hosts x 1, type-A connectors
Wi-Fi Antenna Connector	UC-8220-T-LX: RP-SMA x 2
Cellular Antenna Connector	UC-8220-T-LX: SMA x 2
GPS Antenna Connector	UC-8220-T-LX: SMA x 1
Expansion Slots	UC-8220-T-LX: mPCIe slot x 2
SIM Format	UC-8220-T-LX: Nano
Number of SIMs	UC-8220-T-LX: 2
Buttons	Programmable button

## Ethernet Interface

Magnetic Isolation Protection	1.5 kV (built-in)
-------------------------------	-------------------

## Serial Interface

Console Port	1 x 4-pin header to DB9 console port
Data Bits	5, 6, 7, 8
Parity	None, Even, Odd, Space, Mark
Stop Bits	1, 1.5, 2

## Serial Signals

RS-232	TxD, RxD, RTS, CTS, DTR, DSR, DCD, GND
RS-422	Tx+, Tx-, Rx+, Rx-, GND
RS-485-2w	Data+, Data-, GND
RS-485-4w	Tx+, Tx-, Rx+, Rx-, GND

## CAN Interface

No. of Ports	1
Connector	DB9 male
Baudrate	10 to 1000 kbps
Industrial Protocols	CAN 2.0A, CAN 2.0B
Isolation	2 kV (built-in)
Signals	CAN_H, CAN_L, CAN_GND, CAN_SHLD, CAN_V+, GND

## Digital Inputs

Connector	Screw-fastened Euroblock terminal
Dry Contact	Off: open On: short to GND
Isolation	3K VDC
Sensor Type	Wet contact (NPN) Dry contact
Wet Contact (DI to COM)	On: 10 to 30 VDC Off: 0 to 3 VDC

## Digital Outputs

Connector	Screw-fastened Euroblock terminal
Current Rating	200 mA per channel
I/O Type	Sink
Voltage	24 VDC nominal, open collector to 30 VDC

## Cellular Interface

Cellular Standards	LTE CAT-4
Band Options (US)	UC-8220-T-LX-US-S: LTE Band 2 (1900 MHz) / LTE Band 4 (1700 MHz) / LTE Band 5 (850 MHz) / LTE Band 13 (700 MHz) / LTE Band 17 (700 MHz) UC-8220-T-LX-US-S: UMTS/HSPA 850 MHz / 1900 MHz Carrier Approval: Verizon, AT&T
Band Options (EU)	UC-8220-T-LX-EU-S: LTE Band 1 (2100 MHz) / LTE Band 3 (1800 MHz) / LTE Band 5 (850 MHz) / LTE Band 7 (2600 MHz) / LTE Band 8 (900 MHz) / LTE Band 20 (800 MHz) UC-8220-T-LX-EU-S: UMTS/HSPA 850 MHz / 900 MHz / 1900 MHz / 2100 MHz
Band Option (APAC)	UC-8220-T-LX-AP-S: LTE Band 1 (2100 MHz) / LTE Band 3 (1800 MHz) / LTE Band 5 (850 MHz) / LTE Band 7 (2600 MHz) / LTE Band 8 (900 MHz) / LTE Band 28 (700 MHz) UC-8220-T-LX-AP-S: UMTS/HSPA 850 MHz / 900 MHz / 1900 MHz / 2100 MHz

## GPS Interface

Receiver Types	72-channel u-blox M8 engine GPS/GLONASS/Galileo
Accuracy	Position: 2.5 m CEP SBAS: 2.0 m CEP
Acquisition	Aided starts: 3 sec Cold starts: 26 sec
Sensitivity	Cold starts: -148 dBm Tracking: -164 dBm
Time Pulse	0.25 Hz to 10 MHz

## LED Indicators

System	Power x 2 Programmable x 1 SIM card indicator x 1
Wireless Signal Strength	Cellular/Wi-Fi x 6

## Power Parameters

No. of Power Inputs	Redundant dual inputs
Input Voltage	12 to 48 VDC

Power Consumption	12 W
Input Current	1 A @ 12 VDC
<b>Reliability</b>	
Alert Tools	External RTC (real-time clock)
Automatic Reboot Trigger	External WDT (watchdog timer)
<b>Physical Characteristics</b>	
Dimensions	141.5 x 120 x 39 mm (5.7 x 4.72 x 1.54 in) 141.5 x 120 x 27 mm (5.7 x 4.72 x 1.06 in)
Housing	SECC Metal
Installation	DIN-rail mounting, Wall mounting (with optional kit)
IP Rating	IP30
Weight	UC-8210: 560 g (1.23 lb) UC-8220: 750 g (1.65 lb)
<b>Environmental Limits</b>	
Ambient Relative Humidity	5 to 95% (non-condensing)
Operating Temperature	UC-8210-T-LX: -40 to 85°C (-40 to 185°F) UC-8210-T-LX-S: -40 to 85°C (-40 to 185°F) UC-8220-T-LX: -40 to 70°C (-40 to 158°F) UC-8220-T-LX-US-S: -40 to 70°C (-40 to 158°F) UC-8220-T-LX-EU-S: -40 to 70°C (-40 to 158°F) UC-8220-T-LX-AP-S: -40 to 70°C (-40 to 158°F)
Storage Temperature (package included)	-40 to 85°C (-40 to 185°F)
Shock	IEC 60068-2-27
Vibration	2 Grms @ IEC 60068-2-64, random wave, 5-500 Hz, 1 hr per axis (without USB devices attached)
<b>Standards and Certifications</b>	
Safety	UL 62368-1, EN 62368-1
EMC	EN 55032/35, EN 61000-6-2/-6-4
EMI	CISPR 32, FCC Part 15B Class A
EMS	IEC 61000-4-2 ESD: Contact: 4 kV; Air: 8 kV IEC 61000-4-3 RS: 80 MHz to 1 GHz: 10 V/m IEC 61000-4-4 EFT: Power: 2 kV; Signal: 1 kV IEC 61000-4-6 CS: 10 V IEC 61000-4-8 PFMF IEC 61000-4-5 Surge: Power: 0.5 kV; Signal: 1 kV
Hazardous Locations	Class I Division 2, ATEX, IECEx <sup>1</sup>
Green Product	RoHS, CRoHS, WEEE

1. Class 1 Division 2, ATEX, and IECEx certifications are underway. Please contact a Moxa sales representative for details.

## MTBF

Time	UC-8210-T-LX: 716,739 hrs UC-8210-T-LX-S: 708,581 hrs UC-8220-T-LX: 650,836 hrs UC-8220-T-LX-US-S: 528,574 hrs UC-8220-T-LX-EU-S: 528,574 hrs UC-8220-T-LX-AP-S: 528,574 hrs
Standards	Telcordia (Bellcore) Standard TR/SR

## Warranty

Warranty Period	5 years
Details	See <a href="http://www.moxa.com/warranty">www.moxa.com/warranty</a>

## Package Contents

Device	1 x UC-8200 series computer
Documentation	1 x quick installation guide 1 x warranty card
Installation Kit	1 x DIN-rail kit (preinstalled) 1 x power jack 6 x M2.5 mounting screws for the cellular module
Cable	1 x console cable

## Dimensions

### UC-8210

Unit: mm (inch)

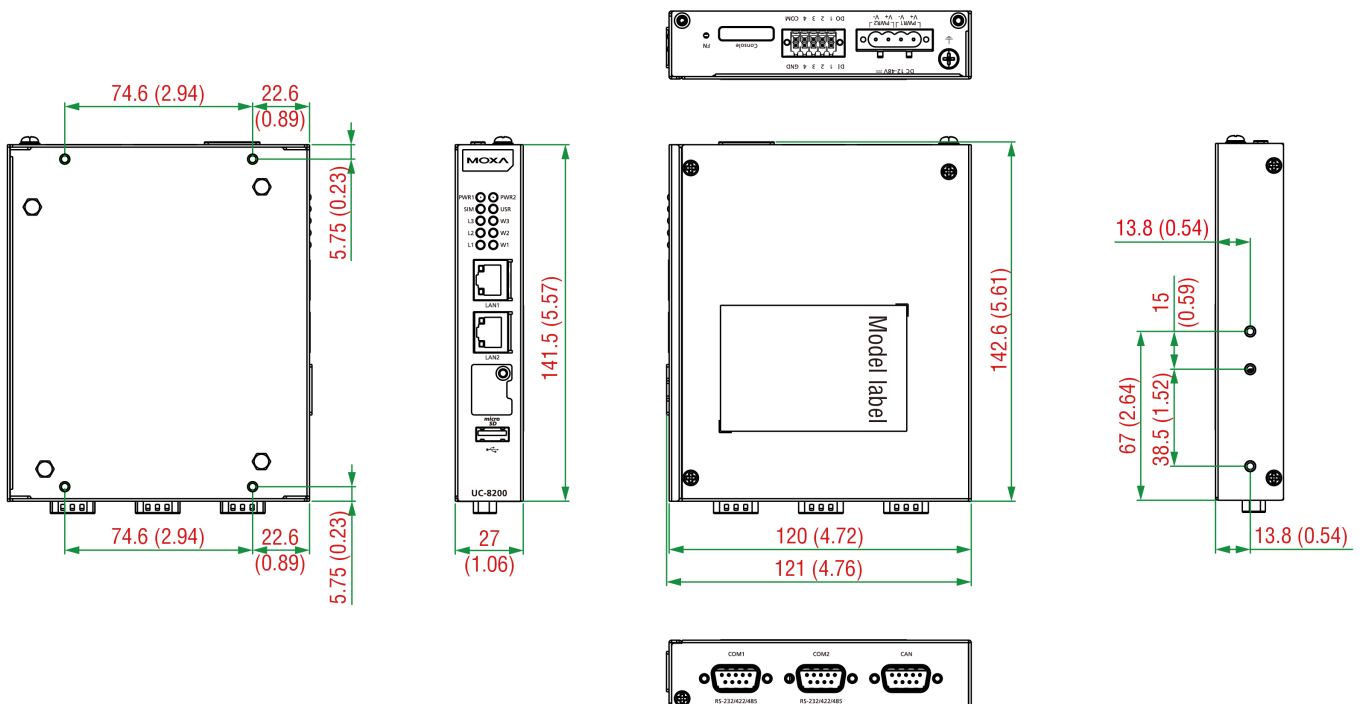

## UC-8220

Unit: mm (inch)

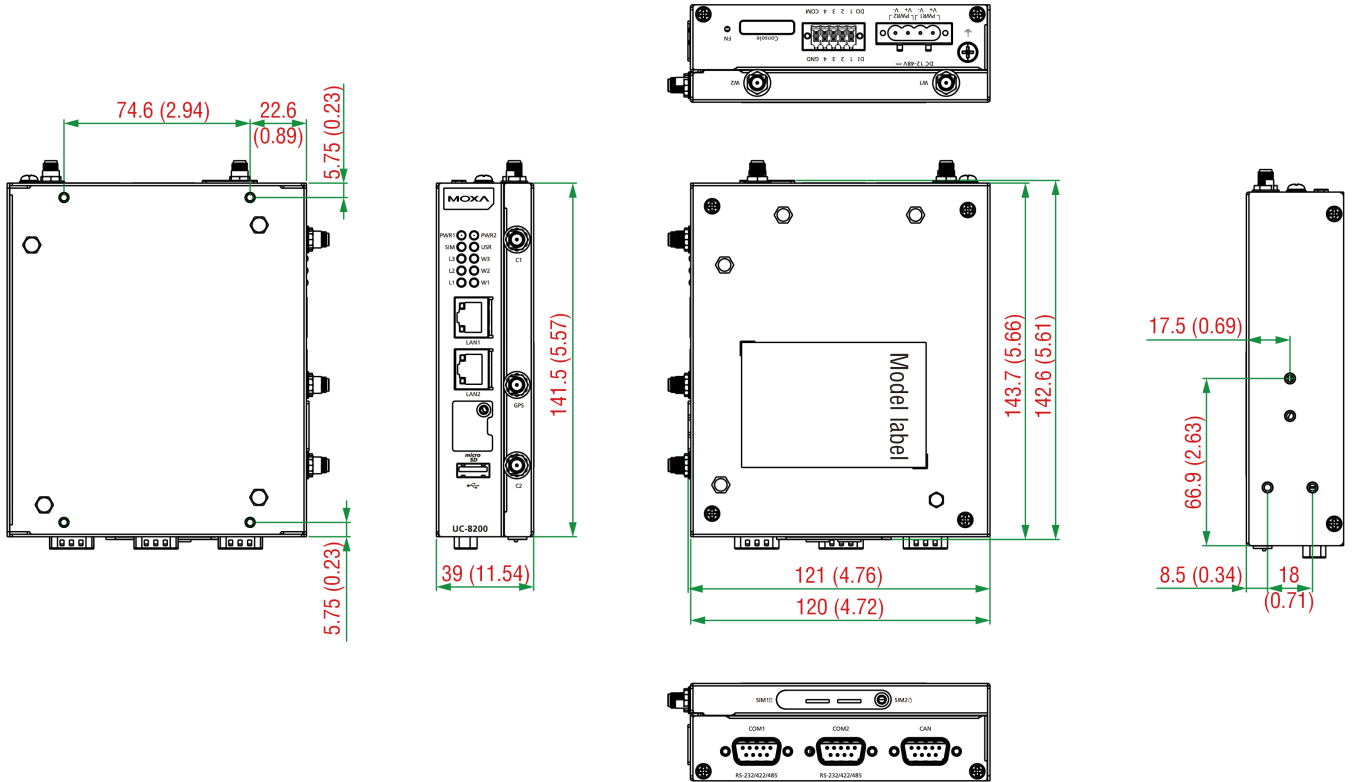

## Ordering Information

Model Name	CPU	RAM	Storage	TPM	mPCIe Slot 1 for LTE Module	mPCIe Slot 2 for Wi-Fi Module	Operating Temperature
UC-8210-T-LX	1 GHz Dual Core	2 GB	8 GB	-	-	-	-40 to 85°C
UC-8210-T-LX-S	1 GHz Dual Core	2 GB	8 GB	Built-in	-	-	-40 to 85°C
UC-8220-T-LX	1 GHz Dual Core	2 GB	8 GB	-	Reserved	Reserved	-40 to 70°C
UC-8220-T-LX-US-S	1 GHz Dual Core	2 GB	8 GB	Built-in	US region LTE module preinstalled	Reserved	-40 to 70°C
UC-8220-T-LX-EU-S	1 GHz Dual Core	2 GB	8 GB	Built-in	Europe region LTE module preinstalled	Reserved	-40 to 70°C
UC-8220-T-LX-AP-S	1 GHz Dual Core	2 GB	8 GB	Built-in	APAC region LTE module preinstalled	Reserved	-40 to 70°C

## Accessories (sold separately)

### Power Adapters

PWR-24270-DT-S1 Power adapter, input voltage 90 to 264 VAC, output voltage 24 V with 2.5 A DC load

### Power Cords

PWC-C7AU-2B-183 Power cord with Australian (AU) plug, 2.5A/250V, 1.83 m

PWC-C7UK-2B-183 Power cord with United Kingdom (UK) plug, 2.5A/250V, 1.83 m

PWC-C7US-2B-183 Power cord with United States (US) plug, 10A/125V, 1.83 m

PWC-C7EU-2B-183 Power cord with Continental Europe (EU) plug, 2.5A/250V, 1.83 m

PWC-C7CN-2B-183 Power cord with two-prong China (CN) plug, 1.83 m

## Power Wiring

CBL-PJTB-10	Non-locking barrel plug to bare-wire cable
-------------	--

## Cables

CBL-F9DPF1x4-BK-100	Console cable with 4-pin connector, 1 m
---------------------	---

## Wi-Fi Wireless Modules

UC-8200 WiFi-AC	Wi-Fi package, includes Wi-Fi module, 6 screws, heat sink, and pad
-----------------	--

## Antennas

ANT-LTEUS-ASM-01	GSM/GPRS/EDGE/UMTS/HSPA/LTE, omni-directional rubber duck antenna, 1 dBi
ANT-LTE-ASM-04 BK	LTE Stick antenna that covers 704-960/1710-2620 MHz providing omnidirectional radiation with a gain of 4.5 dBi.
ANT-LTE-OSM-03-3m BK	Multi-band antenna that covers 700-2700 MHz. Specially designed for 2G, 3G, and 4G applications. Magnetic mounting is available
ANT-LTE-ASM-05 BK	LTE stick antenna that covers 704-960/1710-2620 MHz with a gain of 5 dBi.
ANT-LTE-OSM-06-3m BK MIMO	Multi-band antenna that covers 700-2700/2400-2500/5150-5850 MHz frequencies. Screw-fastened mounting and full IP67 waterproofing are available.
ANT-WDB-ARM-0202	2.4/5 GHz, panel antenna, 1.8/1.8 dBi, RP-SMA (male)
ANT-GPS-OSM-03-3m BK	GPS/Glonass/Galileo Passive Antenna magnetic type

## DIN-Rail Mounting Kits

UC-8220 DIN-Rail Kit	DIN-rail mounting kit with 4 M3 screws
UC-8210 DIN-Rail Kit	DIN-rail mounting kit with 4 M3 screws

## Wall-Mounting Kits

UC-8200 Wall-Mounting Kit	Wall-mounting kit with 4 M3 screws
---------------------------	------------------------------------

© Moxa Inc. All rights reserved. Updated Mar 17, 2020.

This document and any portion thereof may not be reproduced or used in any manner whatsoever without the express written permission of Moxa Inc. Product specifications subject to change without notice. Visit our website for the most up-to-date product information.