

2 dBi Ground Independent Tunable Poly Spring Vehicular Antenna 144-174 MHz NMO Mount Connector



HG142PSGI-NMO

Features

- Broadband performance; ground independent
- NMO Mount, Black Chrome Finish
- Flexible Black Polymer Alloy Spring
- O-ring seal for waterproof construction
- Durable Xenoy™ base with TPV over mold dust seal and grip ring

Applications

- Service Vehicles
- Public Safety
- Public Transportation
- Mining & Construction

Description

This wide band ground independent VHF mobile omnidirectional antenna is ideally suited for multipoint mobile applications including service vehicles, public transportation, public safety, mining and construction vehicles, as well numerous other commercial and industrial applications where mobility and wide coverage is desired. This antenna features a flexible Poly Spring base. Unlike the traditional metal spring base, the Poly Spring will not corrode and does not generate electrical noise when flexed during use. It has a standard TAD/NMO Motorola-type mobile base.

Configuration

Design	Vehicular
Application Band	VHF
Band Type	Single
Radiation Pattern	Omni Directional
Polarization	Linear, Vertical
Ground Plane	Independent
Connector Type	NMO Mount

Electrical Specifications

Description	Minimum	Typical	Maximum	Units
Frequency Range (Tunable Range)	144		174	MHz
Operational Bandwidth (Frequency Dependent)			15-20	MHz
Input VSWR (across operational bandwidth)			2:1	
Center Frequency VSWR			1.2:1	
Impedance		50		Ohms
Gain		2		dBi
Horizontal (Azimuth) Beam Width		Omnidirectional		
Vertical (Elevation) Beam Width		70		Degrees
Input Power			150	Watts

Click the following link (or enter part number in "SEARCH" on website) to obtain additional part information including price, inventory and certifications:
[2 dBi Ground Independent Tunable Poly Spring Vehicular Antenna 144-174 MHz NMO Mount Connector HG142PSGI-NMO](#)

2 dBi Ground Independent Tunable Poly Spring Vehicular
Antenna 144-174 MHz NMO Mount Connector

HG142PSGI-NMO



Mechanical Specifications

Base Material	Xenoy TM w/TPV over mold grip ring
Whip Material	17-7 SS
Whip Finish	Black Chrome
Mounting Application	¾ inch thru-hole NMO Mount
Spring Material	Black Molded Polymer Alloy

Size by Frequency

Length @ 144 MHz	46 in [116.84 cm]
------------------	-------------------

2 dBi Ground Independent Tunable Poly Spring Vehicular
Antenna 144-174 MHz NMO Mount Connector

HG142PSGI-NMO



Installation Instructions

**HG142PSGI-NMO (144-174 MHz) 2 dBi
VHF GROUND PLANE INDEPENDENT ANTENNA**

Congratulations on your selection of another quality antenna product from L-COM.

L-COM is committed to continually provide the greatest antenna VALUE for your wireless applications.

1. Parts (Figure 1):

Verify all parts are included with the Antenna as shown in Figure 1.

- A. Antenna Whip
- B. e/m-Flex™ Poly Spring Assembly
- C. NMO Base Adapter
- D. O-Ring

2. Tools/Materials Required:

- A. Tool for cutting stainless steel whip
- B. Hex Wrench (3/32")
- C. **Note:** Special tools are not required to install the antenna. The antenna is intended to be installed using a firm hand torque until the sealing O-ring is completely compressed against the installation surface.

3. Pre-Installation (Figure 2):

- A. **Optimal VSWR and Bandwidth:** Best performance is achieved when mounted to a non-metallic surface or small metal L-Bracket.
- B. **Mounting Option:** Metallic ground plane surface.
- C. Ensure O-ring is properly seated within O-ring groove as shown in Figure 2.
- D. **Important:** Verify proper operational Frequency, as labeled. (Figure2).
- E. Read and follow all Whip Cutting Instructions supplied for this model.

4. Tuning and Installation (Figure 3):

- A. Verify contact spring is completely extended. If necessary, adjust by pulling the contact outward.
- B. Thread NMO Base Coil Adapter onto the vehicle NMO mount. Tighten by hand until O-Ring is completely seated.
- C. Thread Spring onto NMO Base Coil Adapter. Firmly torque by hand.
- D. Refer to whip cutting instructions. Cut whip length according to desired frequency and either ground plane or no ground plane installation.
- E. Verify VSWR. Apply firm torque to whip adapter set screws. (2 ea.).

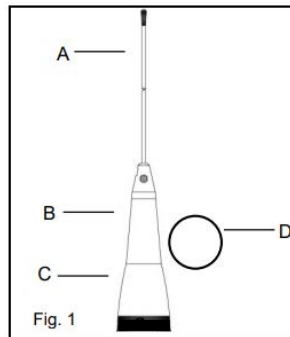

Fig. 1

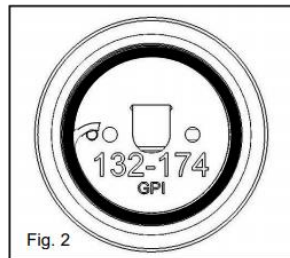

Fig. 2

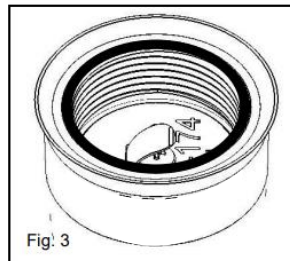

Fig. 3

2 dBi Ground Independent Tunable Poly Spring Vehicular
Antenna 144-174 MHz NMO Mount Connector

HG142PSGI-NMO



WHIP CUTTING INSTRUCTIONS

“Ground Plane” and “No Ground Plane” Installations
PLEASE CAREFULLY READ ALL INSTRUCTIONS BEFORE CUTTING THE WHIP

CENTER FREQUENCY (± BANDWIDTH)	TUNED WHIP LENGTH “W” NO GROUND PLANE		TUNED WHIP LENGTH “W” GROUND PLANE	
	(inches)	(mm)	(inches)	(mm)
144 (± 7.5)	41-5/16	1050	37-7/8	963
150 (± 7.5)	38-9/16	980	35-5/8	905
155 (± 8)	36-1/2	928	34-1/4	870
160 (± 8)	34-1/2	876	32-1/2	826
165 (± 8)	32-3/4	833	30-3/4	781
170 (± 9)	31-1/16	789	29-5/16	745
174 (± 9)	30-1/16	763	28-1/4	714

Table 1

1. **IMPORTANT: Before Cutting.**

OPTIMAL PERFORMANCE: This antenna is specifically designed for precision VSWR performance at the desired frequency. Tuning the whip per Table 1 will provide optimal VSWR match across the bandwidth specified. VSWR bandwidth may vary depending on the actual installation surface material, location, bracket type and size.

CUTTING NOTE: The whip can be cut using a grinding wheel or shearing tool designed for this purpose. Due to a large variation of installations without a conductive ground plane surface, it is strongly recommended to cut the whip slightly longer than the specified dimension in Table 1. If necessary, continue to trim for best VSWR match. Always verify actual VSWR or Return Loss performance after cutting and installation.

TUNED LENGTH “W”: is determined by measuring the distance between the top of the whip adapter and the top of the whip.

See Figure 4. NOTE: The actual cut length will be approximately 1” (25mm) longer than TUNED WHIP LENGTH “W”.

- Choose the column in Table 1 for “Ground Plane” or “NO Ground Plane” installation.
- Identify the desired center frequency of operation.
- Imperial and Metric units are given for convenience. Cut the whip as required to establish the specified **TUNED WHIP LENGTH “W”** as shown in Figure 4.
- Verify VSWR. Secure set screws (2 ea.).

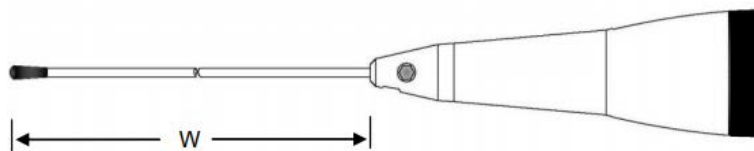

[Note: Add 1” (25mm) to Tuned Length “W” when cutting whip.] Fig. 4

2 dBi Ground Independent Tunable Poly Spring Vehicular Antenna 144-174 MHz NMO Mount Connector



HG142PSGI-NMO

Environmental Specifications

Temperature

Operating Range

-40 to +85 deg C

Humidity

95%

Compliance Certifications (see [product page](#) for current document)

Plotted and Other Data

Notes:

Typical Radiation Pattern

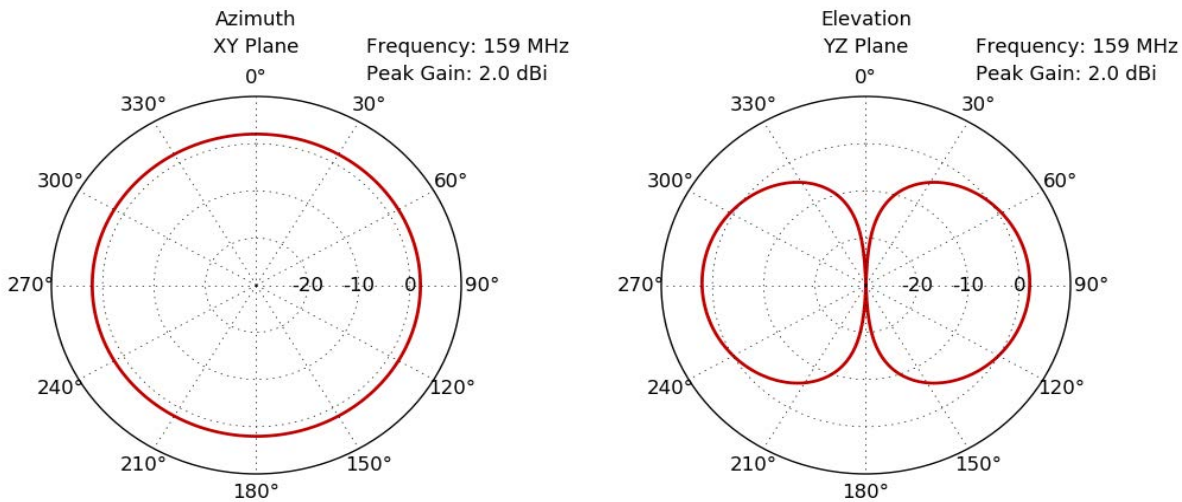

2 dBi Ground Independent Tunable Poly Spring Vehicular Antenna 144-174 MHz NMO Mount Connector from L-com has same day shipment for domestic and International orders. Our portfolio includes coaxial cable assemblies, connectors, adapters and custom products as well as lightning and surge protectors, NEMA rated enclosures, and an RF product line which includes antennas, amplifiers, passive, and active components.

The information contained within this document is accurate to the best of our knowledge and representative of the part described herein. It may be necessary to make modifications to the part and/or the documentation of the part in order to impliment improvements. L-com reserves the right to make such changes as required. Unless otherwise stated, all specifications are nominal. L-com does not make any representation or warranty regarding the suitability of the part described herein for any particular purpose, and L-com does not assume liability arising out of the use of any part or document.

2 dBi Ground Independent Tunable Poly Spring Vehicular Antenna 144-174 MHz NMO Mount Connector

L-com CAD Drawing

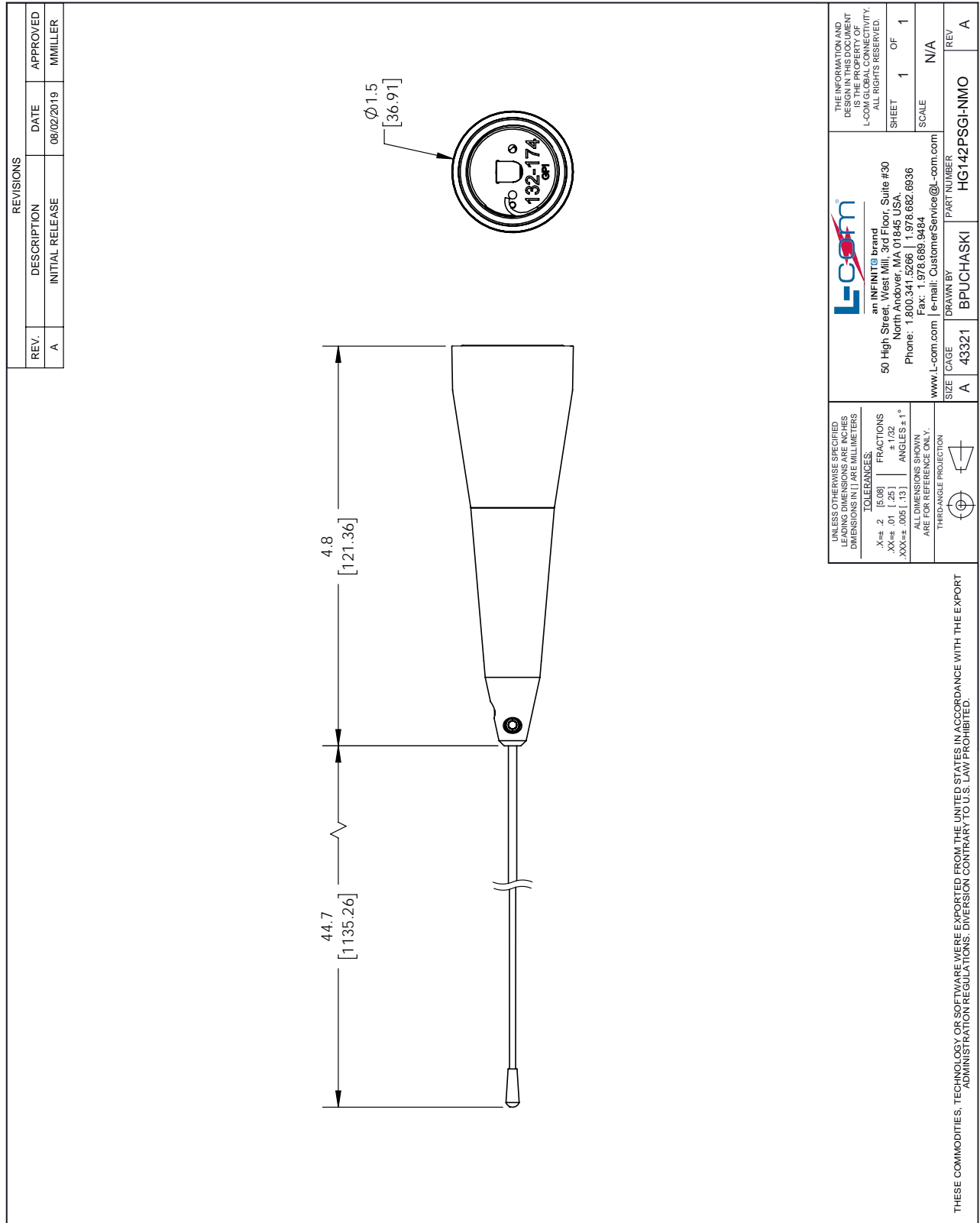

<p>UNLESS OTHERWISE SPECIFIED LEADING DIMENSIONS ARE INCHES DIMENSIONS IN [] ARE MILLIMETERS</p> <p>TOLERANCES:</p> <p>.X = ± .2 [5.08] FRACTIONS ± 1/32</p> <p>.XX = ± .01 [.25] ANGLES ± 1°</p> <p>.XXX = ± .005 [.13] ALL DIMENSIONS SHOWN ARE FOR REFERENCE ONLY.</p> <p>THIRD-ANGLE PROJECTION</p>	<p style="text-align: center;">L-com</p> <p style="text-align: center;">an INFINITE brand</p> <p style="text-align: center;">50 High Street, West Mill, 3rd Floor, Suite #30 North Andover, MA 01845 USA Phone: 1 800 341 5266 1 978 682 6936 Fax: 1 978 689 9484 www.L-com.com e-mail: CustomerService@L-com.com</p>	<p>THE INFORMATION AND DESIGN IN THIS DOCUMENT IS THE PROPERTY OF L-COM GLOBAL CONNECTIVITY. ALL RIGHTS RESERVED.</p> <p>SHEET 1 OF 1</p> <p>SCALE N/A</p>
<p>SIZE A</p> <p>DRAWN BY BPUCHASKI</p>	<p>PART NUMBER HG142PSG1-NMO</p>	<p>REV A</p>

THESE COMMODITIES, TECHNOLOGY OR SOFTWARE WERE EXPORTED FROM THE UNITED STATES IN ACCORDANCE WITH THE EXPORT ADMINISTRATION REGULATIONS. DIVERSION CONTRARY TO U.S. LAW PROHIBITED.

T-Rev.B