

**PUSH BUTTON START/INTERNAL:** The 409 has a Push Button built into its front dial. When pressed, the timer starts and provides an interval time delay. The 409 has a set of DPDT output contacts. When the Push Button is pressed with power applied, the contacts immediately transfer. After the timer has timed out, the contacts release. Unit timing will reset with power loss.

**UNIVERSAL POWER SUPPLY:** All 409 timers can be powered using 24-240 VAC or 24 VDC power, greatly simplifying ordering and inventory management of replacement units.

**HIGH ACCURACY:** The 409's timing circuit is not a simple RC circuit. It utilizes the sophistication of a proprietary integrated circuit that includes counting technology along with a stable oscillator to provide repeatable time delays.

**1/16 DIN HOUSING:** The 48mm<sup>2</sup> (1/16 DIN) housing is compact. The 409 is mounted in an 8-pin round (octal) socket. With an optional mounting clip, the 409 can be panel mounted.

The dial on the 409 is extra large and is easy to read. When fractional ranges are selected, decimal points are clearly indicated.

The Range Select Switch is located on the side of the unit, so that when panel mounted, this switch is not accessible to the operator. This tamper proof feature prevents unauthorized or hazardous changes to the timing range from being made.

## OPERATIONS

Timing begins when the front green push button is pressed. This energizes the DPDT relay and starts an oscillator which runs at a frequency determined by the time setting. A fixed number of counts from the oscillator determines the end of the timing cycle.

The LED indicates the status of the relay output. It comes on when the green push button is pressed and remains on steady during the cycle. The LED turns off after the cycle is completed and the contacts released.

## MODEL NUMBER

MODEL NUMBER	409B			2	
<b>RANGE</b>					
Six dial-selected ranges (1 or 10 SEC/MIN/HRS)	100				
Six dial-selected ranges (5 or 50 SEC/MIN/HRS)	500				
<b>VOLTAGE &amp; FREQUENCY</b>					
12 VDC		E			
24 to 240 VAC (50/60 Hz) and 24 VDC		F			
<b>ARRANGEMENT</b>					
8-Pin, Push Button Start, Interval Operation			2		
<b>FEATURES</b>					
Standard					X
Special					K

## ACCESSORIES

8-Pin surface/DIN rail socket	000-825-85-00
Hold down for above socket (Requires two per unit)	407-025-13-00
Panel mounting bracket	405-320-02-00
Plug-in socket kit (8-pin)	319-261-45-00
8-Pin panel socket with rear facing terminals	000-825-90-00

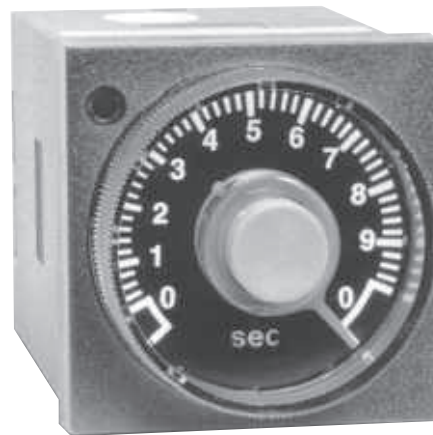

## 1/16 DIN Push-Button Timer

- Push Button Start, Interval Timing Mode
- Push Button Integral to front dial
- Output Contacts rated 10A at 120/240 VAC and 30 VDC
- Six Timing Ranges in a single unit:
  - 1 and 10 SEC, MIN, and HRS
  - 5 and 50 SEC, MIN, and HRS
- Universal Power Supply: 24-240 VAC and 24 VDC
- 48mm<sup>2</sup> DIN Standard housing
- Large and easy to read dial shows decimal points
- Round (octal) socket mount or mount in panel cutout
- Range and Mode select are tamper proof when panel-mounted

**DIMENSIONS (INCHES/MILLIMETERS)**

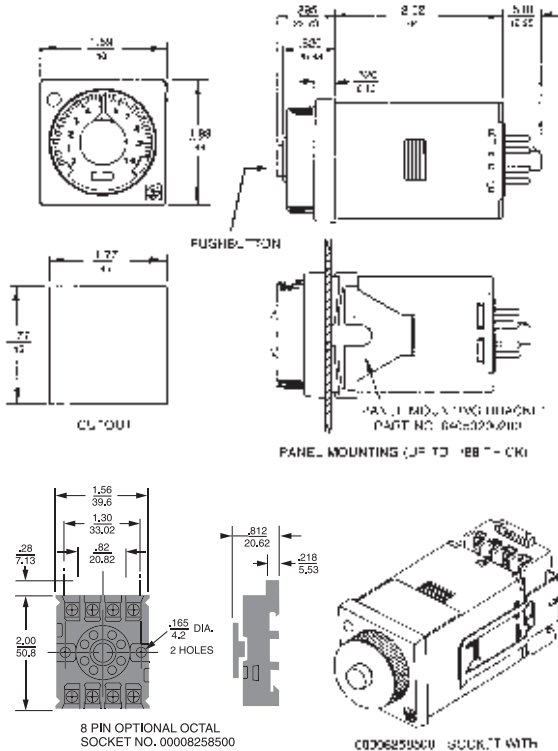

**WIRING**

**MODEL 409B...F2X**

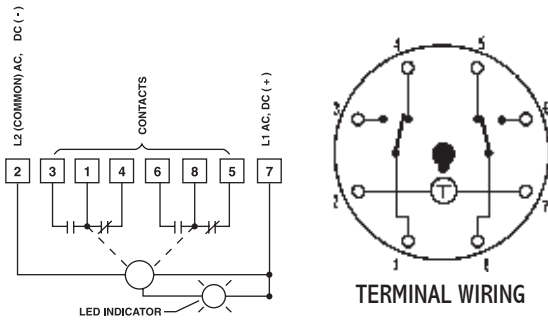

**TYPICAL CIRCUITS**

**409B...F2X**

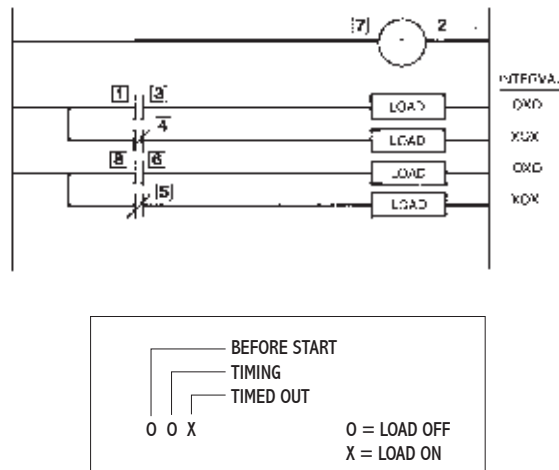

**SPECIFICATIONS**

<b>MODELS</b>	409B100F2X Push Button Start, Interval Timing with (1) DPDT relay (1 or 10 SEC/MIN/HRS)
	409B500F2X Push Button Start, Interval Timing with (1) DPDT relay (5 or 50 SEC/MIN/HRS)
	Both models available in 6 ranges from 1 SEC to 10 HRS or 5 SEC to 50 HRS
<b>CONTACT RATING</b>	Rated 10 AMPS resistive at 30 VDC or 250 VAC (or less) 1/8 HP @ 120 VAC 1/4 HP @ 240 VAC 240 VA @ 240 VAC LIFE: 10 million operation with no load 100,000 operations with: 10 AMPS at 30 VDC (or less) or 10 AMPS at 250 VAC (or less)
<b>CONTACT MATERIAL</b>	Silver Nickel
<b>TEMPERATURE RATING</b>	0° to 122°F (-18° to 50°C)
<b>MOUNTING</b>	Plug-in octal base; mounts in any position with retaining clips. Options: Surface mounting socket DIN rail mounting socket Panel-mounting adapter kit Plug-on socket kit
<b>POWER REQUIREMENTS</b>	Universal power supply - reverse polarity protected Unit will accept power from 24 to 240 VAC, 50 or 60 Hz, (+10%, -20%) 24 VDC (+20%, -20%) AC Inrush - 1.5 Amps Power required - 1.2 watts DC Maximum ripple @ 100 Hz - 5% Current required - 50mA Power required - 1.2 watts
<b>REPEAT ACCURACY</b>	Varies as a function of temperature. Any voltage (constant temperature): ±0.5%* Any voltage (0 F to 140 F): ±2.0%* *Variation from average actual time.
<b>MINIMUM SETTING</b>	2% of range, with the exception of 50 mSEC on the 1 second range
<b>SETTING ACCURACY</b>	±5% of range
<b>RESET</b>	a 0 to 20 mSEC power interruption: guaranteed no reset b 20 to 65 mSEC; it may reset (40 mSEC typical reset) c Over 65 mSEC guaranteed to reset
<b>WEIGHT</b>	5 oz. (140 g)