

ROP520

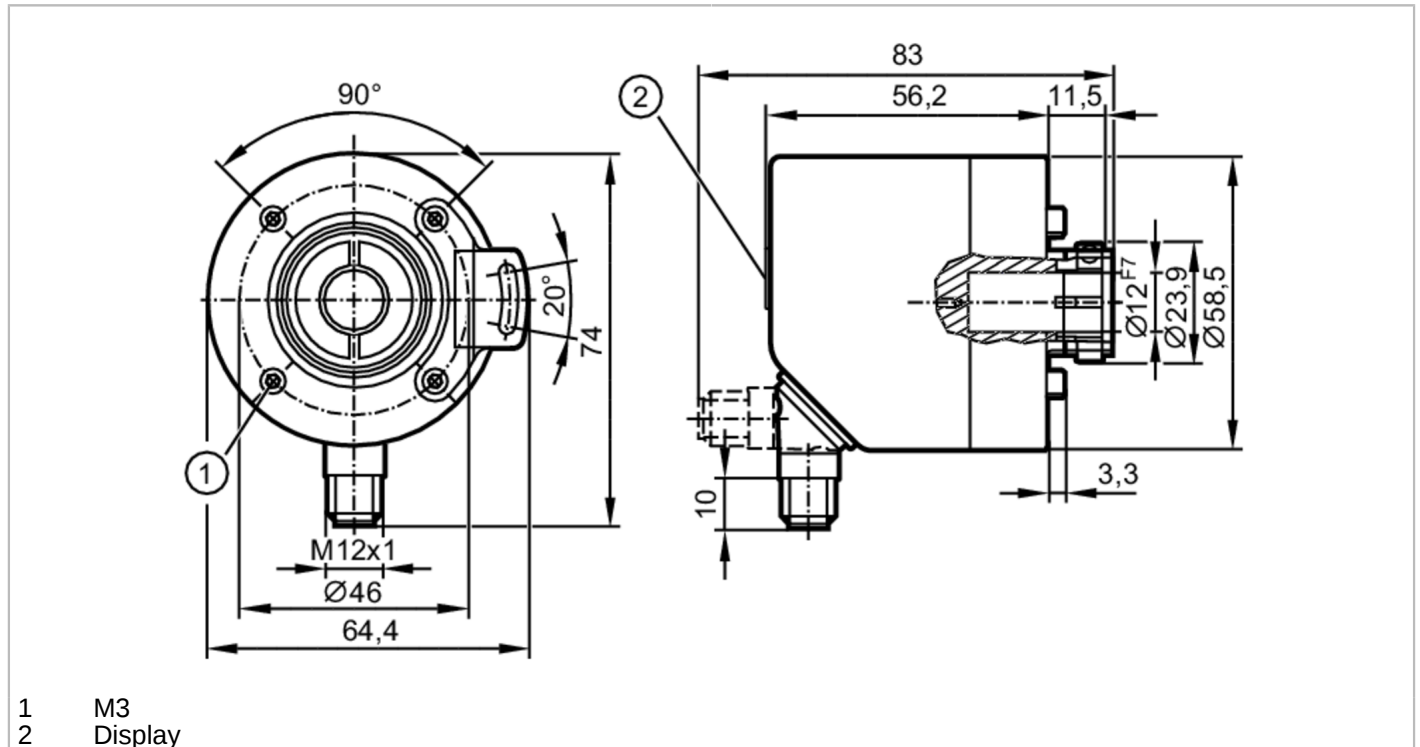

Incremental encoder with hollow shaft and display

INCREMENTAL ENCODER PERFORMANCE LINE



- 1 M3
- 2 Display



Product characteristics	
Resolution	1...10000; (configurable; Factory setting: 1024) resolution
Communication interface	IO-Link
Shaft design	hollow shaft open to one side
Shaft diameter [mm]	12
Application	
Function principle	incremental
Detection system	magnetic
Application	encoder; Speed monitor; Counter
Electrical data	
Operating voltage [V]	4.75...30 DC
Current consumption [mA]	< 350
Protection class	III
Reverse polarity protection	yes
Max. revolution electrical [U/min]	12000
Outputs	
Electrical design	HTL/TTL
Switching frequency [kHz]	1000
Factory setting	Output function: HTL (50 mA)
Short-circuit protection	yes
Phase difference A und B [°]	90
Measuring/setting range	
Resolution	1...10000; (configurable; Factory setting: 1024) resolution

ROP520



Incremental encoder with hollow shaft and display

INCREMENTAL ENCODER PERFORMANCE LINE

Speed monitor		
Set point SP	[U/min]	-9994...9999
Set point SP	[Hz]	-166.6...166.7
Reset point rP	[U/min]	-9999...9994
Reset point rP	[Hz]	-166.7...166.6
Counter		
Preset point		1...9999
Accuracy / deviations		
Accuracy	[°]	0.1
Software / programming		
Parameter setting options		encoder; Resolution; Direction of rotation; HTL; TTL; Speed monitor; Resolution
Interfaces		
Communication interface		IO-Link
Transmission type		COM 2
IO-Link revision		1.1
SIO mode		yes
Min. process cycle time	[ms]	2.3
Operating conditions		
Ambient temperature	[°C]	-40...85
Storage temperature	[°C]	-40...85
Max. relative air humidity	[%]	95; (Condensation not permissible)
Protection		IP 65; (IP 67: on the housing; IP 65: on the shaft)
Tests / approvals		
Shock resistance		100 g
Vibration resistance		20 g
MTTF	[years]	218
Mechanical data		
Weight	[g]	478.5
Dimensions	[mm]	Ø 58.5 / L = 69
Material		flange: aluminum; housing: stainless steel (1.4521 / 444); plug: stainless steel (1.4401 / 316); display window: PEI
Max. revolution, mechanical	[U/min]	12000
Max. starting torque	[Nm]	2
Reference temperature torque	[°C]	20
Shaft design		hollow shaft open to one side
Shaft diameter	[mm]	12
Shaft material		stainless steel
Installation depth/shaft	[mm]	27
Max. axial shaft misalignment	[mm]	0,5

ROP520



Incremental encoder with hollow shaft and display

INCREMENTAL ENCODER PERFORMANCE LINE

Displays / operating elements	
Display	10-segment display, red/ green 4-digit configurable
	2 x LED, yellow
	5 x LED, green

Accessories	
Accessories (supplied)	Stator coupling: 1

Electrical connection	
IO-Link	
1	L+
2	not to be used
3	L-
4	IO-Link
5	not to be used
6	not to be used
7	not to be used
8	not to be used
screen	plug

encoder	
1	UB
2	A
3	GND
4	Z/0-Pulse (90 deg)
5	B
6	A-
7	B-
8	Z-
screen	plug

Preset counter	
1	UB
2	IN1
3	GND
4	not to be used
5	OUT1
6	not to be used
7	not to be used
8	not to be used
screen	plug

ROP520



Incremental encoder with hollow shaft and display

INCREMENTAL ENCODER PERFORMANCE LINE

Speed monitor

1	UB
2	OUT2
3	GND
4	not to be used
5	OUT1
6	OUT2-
7	OUT1-
8	not to be used
screen	plug

Connector: 1 x M12, radial, can also be used axially; Moulded body: stainless steel (1.4401 / 316); Maximum cable length: 100 m; (IO-Link: max. 20 m)

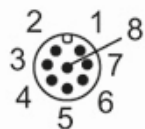

Diagrams and graphs

Pulse diagram

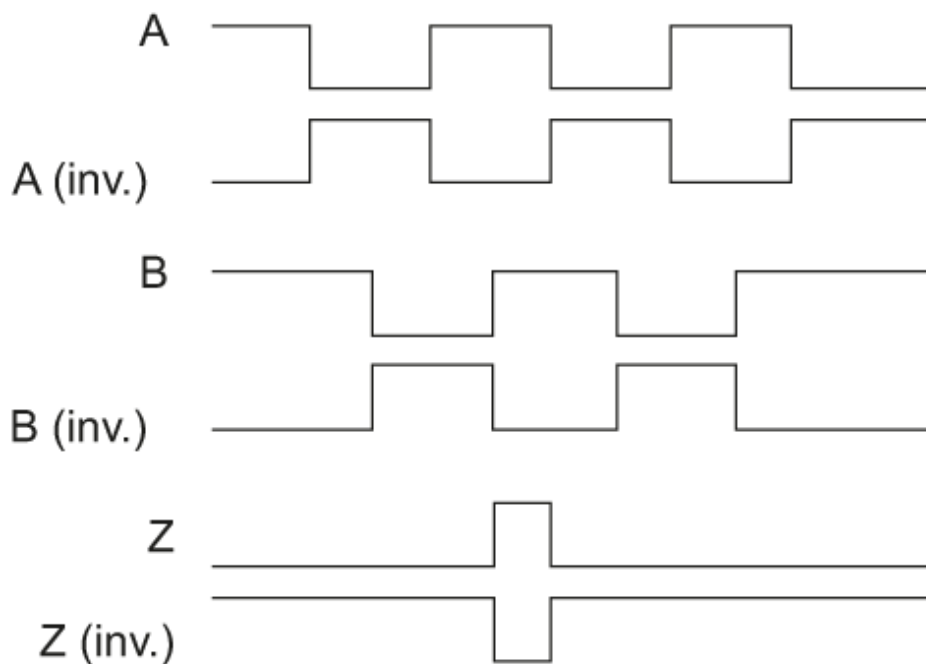

Direction of rotation clockwise (looking at the shaft)