

TRACK ROLLERS

Overview: Track rollers (also known as cam followers) are characterized by their thick-walled outer rings that run directly on a track. The thick outer rings permit high load-carrying capability while minimizing both distortion and bending stresses. Sealed designs with internal thrust washers help extend service life under conditions of infrequent lubrication.

- **Sizes:** Stud-Type: 10 mm – 130 mm (0.3937 in. – 5.1180 in.) O.D.
Yoke-Type: 10 mm – 300 mm (0.3937 in. – 11.816 in.) O.D.
- **Markets:** Ram support rollers, material handling and indexing equipment.
- **Features:** Available in two basic designs: with an inner ring for straddle mounting in a yoke or with an integral stud for cantilever mounting.
- **Benefits:** High load-carrying capability with minimized distortion and bending stresses. Extended service life under conditions of infrequent re-lubrication.



Caged Yoke-Type Track Rollers – Metric Nominal Dimensions

Bore diameter from 10 mm to 17 mm (for NA22)
 00 = 10 mm 02 = 15 mm
 01 = 12 mm 03 = 17 mm

Bore diameter > 17 mm (for NA22)
 05 = 25 mm

NA22

05

2RS

Prefix

NA22 track roller, yoke-type, profiled outer diameter, with inner ring, sealed
RNA22 track roller, yoke-type, profiled outer diameter, without inner ring, sealed
RSTO track roller, yoke-type, profiled outer diameter, without inner ring, without washers
STO track roller, yoke-type, profiled outer diameter, with inner ring, without washers
NATR track roller, yoke-type, profiled outer diameter, with inner ring, with washers

Suffix

TN molded cage of reinforced, engineered polymer
DZ cylindrical outer diameter
ZZ two washers for track rollers used for axial location
.2RS lip contact seal on each side of the bearing
ZZ.DZ two washers for track rollers used for axial location; cylindrical outer diameter
DZ.TN cylindrical outer diameter; molded cage of reinforced, engineered polymer
.2RS.DZ lip contact seal on each side of bearing; cylindrical outer diameter

STO

25

DZ

Bore diameter for STO, NATR
 25 = 25 mm
 45 = 45 mm

Caged Stud-Type Track Rollers – Metric Nominal Dimensions

Prefix Modification
 E eccentric stud

Suffix
SK hexagonal wrench socket in stud head
DZ.2RS cylindrical outer diameter: lip contact seals on each end of bearing
.2RS lip contact seal on each side of the bearing
DZ cylindrical outer diameter

KR

E

22

.2RS

Prefix
KR track roller, stud-type with cage, profiled outer diameter

Outer Diameter
 22 = 22 mm

Full Complement Track Rollers – Inch Nominal Dimensions

Prefix
CR stud-type
YCR yoke-type

Outer Diameter
8 = $\frac{8}{16}$ = $\frac{1}{2}$ in. **32** = $\frac{32}{16}$ = 2 in.
16 = $\frac{16}{16}$ = 1 in. **36** = $\frac{36}{16}$ = 2 $\frac{1}{4}$ in.

CR S B E - 16

Design Modifications

S seals with internal thrust washers
B hex wrench socket (CR Type only)
C crowned O.D.
E eccentric stud (CR Type only)

Full Complement Yoke-Type Track Rollers – Metric Nominal Dimensions

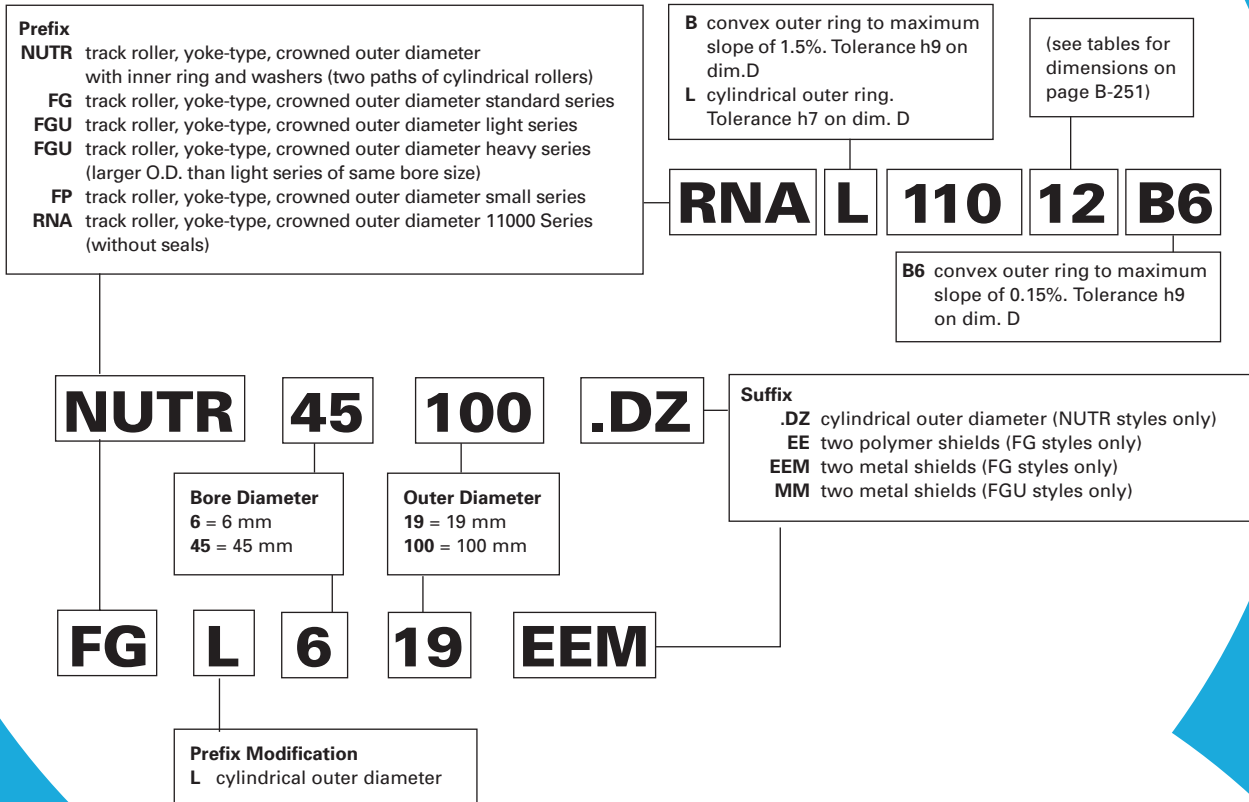

Full Complement Stud-Type Track Rollers – Metric Nominal Dimensions

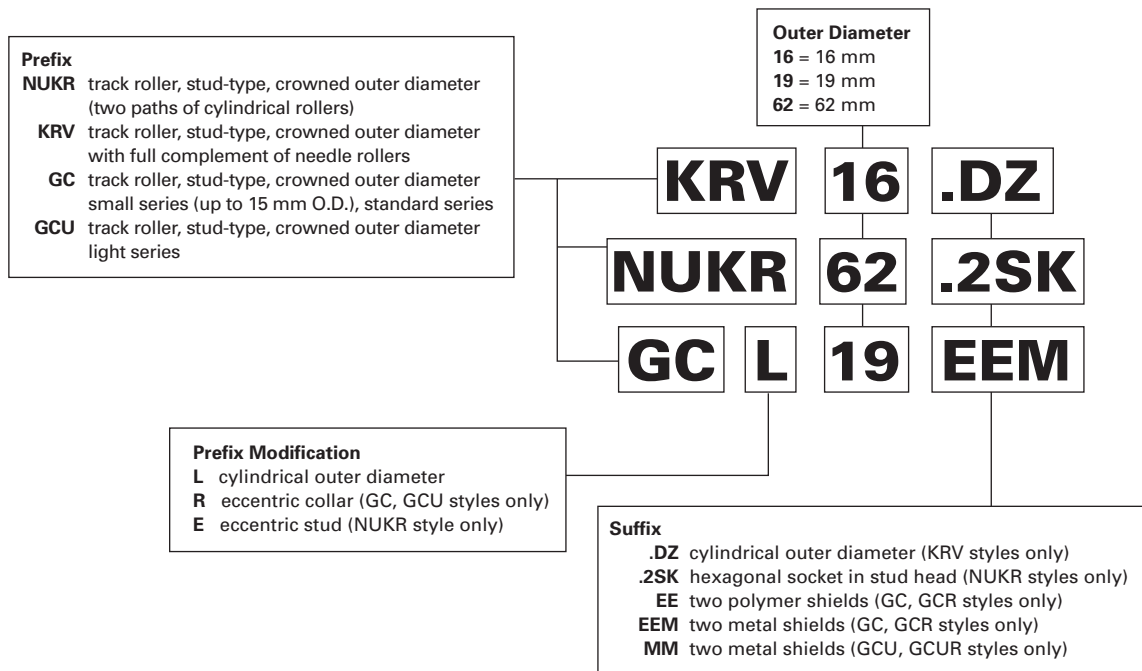

B

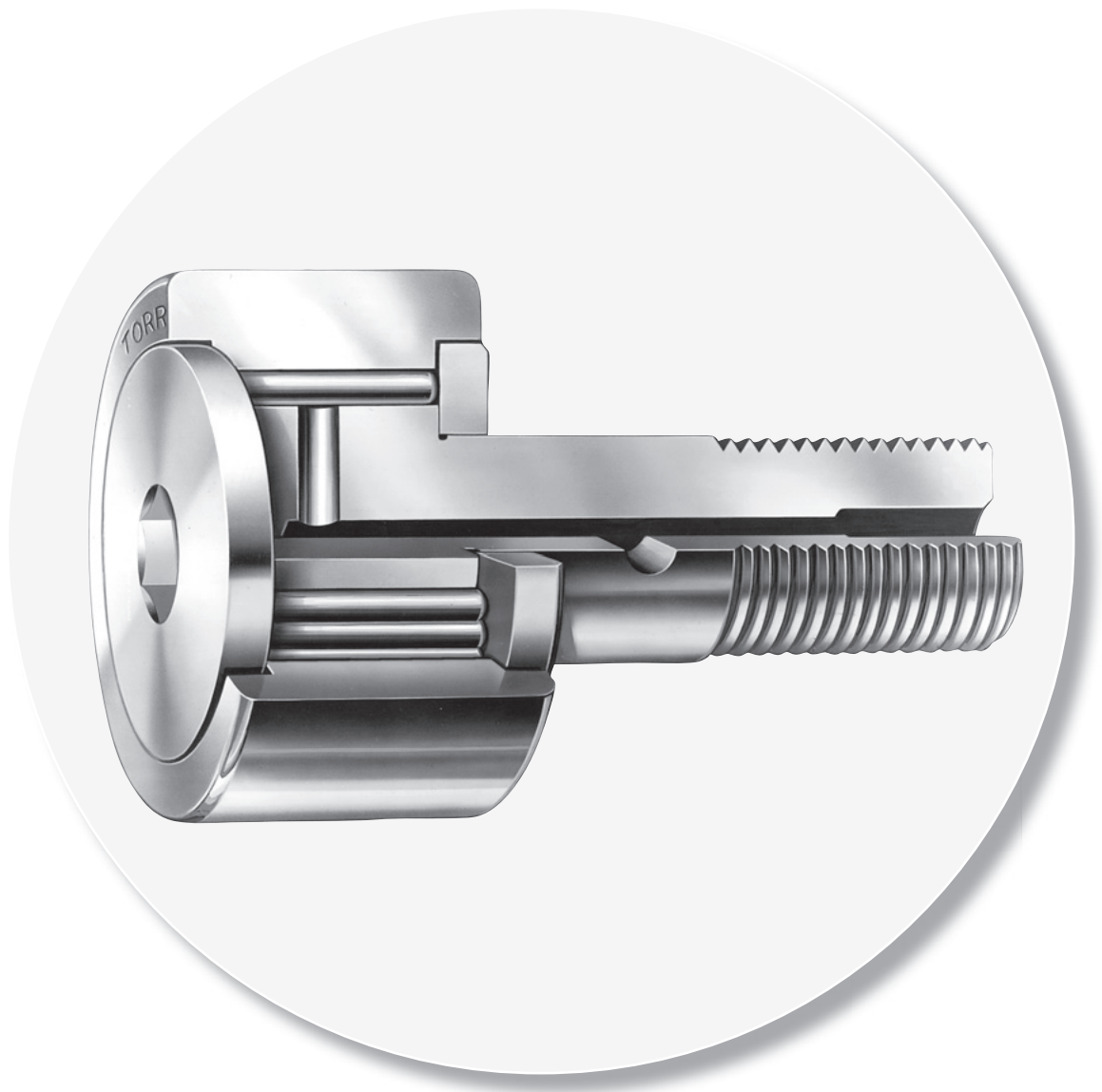

Stud-Type and Yoke-Type Track Roller

STUD-TYPE AND YOKE-TYPE TRACK ROLLERS METRIC SERIES Page

Introduction B-212

STUD-TYPE METRIC SERIES

Needle Roller and Cage Assemblies (KR Series) B-222

Needle Roller and Cage Assemblies, Sealed
(KR...2S Series) B-224

Full Complement with Needle Rollers (KRV Series) or
Cylindrical Rollers (NUKR Series) B-226

Full Complement, Small Series, Unsealed (GC Series) B-228

Full Complement, Standard Series, with or
without Seals (GC Series) B-230

Full Complement, with Metal Seals (GCU...MM Series) B-232

Full Complement, Eccentric (GCR Series) B-234

Full Complement, Eccentric, with Metal Seals
(GCUR...MM Series) B-236

YOKE-TYPE METRIC SERIES

Caged, without Inner Ring, No End Washers
(RSTO Series) B-238

Caged, with Inner Ring, No End Washers (STO Series) B-239

Caged, without Inner Ring, No End Washers,
Sealed (RNA22 Series) B-240

Caged, with Inner Ring, No End Washers,
Sealed (NA22 Series) B-241

Caged, with Inner Ring, with End Washers
(NATR, STO...ZZ Series) B-242

Full Complement, with Inner Ring, with End Washers,
Cylindrical Rollers (NUTR Series) B-243

Page

Full Complement, Non-Separable, Small Series,
Unsealed (FP Series) B-244

Full Complement, Non-Separable, Sealed or Unsealed
(FG Series) B-245

Full Complement, Non-Separable, Light Series,
with Metal Seals (FGU...MM Series) B-248

Full Complement, Non-Separable, Heavy Series,
with Metal Seals (FGU...MM Series) B-249

Full Complement, without Inner Ring, Unsealed
(RNA...B6, RNAB, RNAL Series) B-251

Separate Inner Rings (BIC Series) B-251

STUD-TYPE AND YOKE-TYPE TRACK ROLLERS – FULL COMPLIMENT INCH SERIES

Introduction B-252

Stud-Type Track Rollers CR, CRS Series B-258

Stud-Type Track Rollers CRSB Series B-262

Yoke-Type Track Rollers YCR, YCRS Series B-266





STUD-TYPE AND YOKE-TYPE TRACK ROLLERS

METRIC SERIES

JTEKT track rollers listed in this catalog have been designed with outer rings of a large radial cross section to withstand heavy rolling and shock loads on track-type or cam-controlled equipment. The outer diameters of the outer rings are either crowned or cylindrical. Crowned track rollers are designed to alleviate uneven bearing loading resulting from deflection, bending or misalignment in mounting.

Stud-type track rollers are available in various open designs, as well as with lip contact seals or metal shields.

Yoke-type track rollers are designed for straddle mounting. The various metric series designs are grouped and organized as illustrated below.

REFERENCE STANDARDS ARE:

- **ISO 6278** – needle roller bearings – track rollers – boundary dimensions.
- **ISO 492** – radial bearings – tolerances.
- **DIN 620** – tolerances of ball and roller bearings.
- **ISO 281** – rolling bearings – dynamic load ratings and rating life.

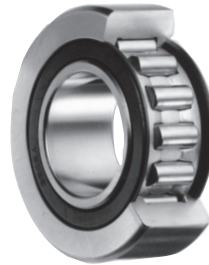

Fig. B-48. Yoke-type track rollers

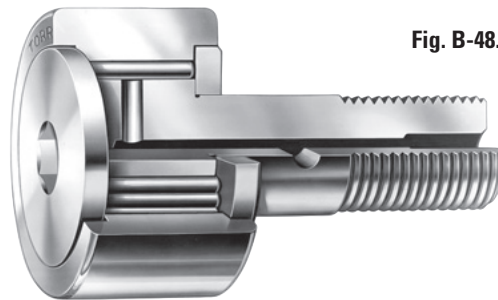

Fig. B-47. Stud-type track rollers

Suffixes – Stud-Type, Metric Series (except GC types)

.2RS	two seals
DZ	cylindrical outer diameter
DZ.2RS	cylindrical outer diameter • two seals
SK	hexagonal socket in flange end
2SK	hexagonal socket in both flange and stud ends

Suffixes – Yoke-Type, Metric Series (except FP or FG types)

DZ.TN	cylindrical outer diameter • molded cage of reinforced engineered polymer
TN	molded cage of reinforced engineered polymer
DZ	cylindrical outer diameter
ZZ	two end washers for the outer ring
ZZ.DZ	two end washers for the outer ring • cylindrical outer diameter
.2RS	two seals
.2RS.DZ	two seals • cylindrical outer diameter

Suffixes – Yoke-Type (FP, FG) and Stud-Type (GC)

EE	polymer shields
EEM	metal shields
MM	metal shields

STUD-TYPE METRIC SERIES TRACK ROLLER TYPES

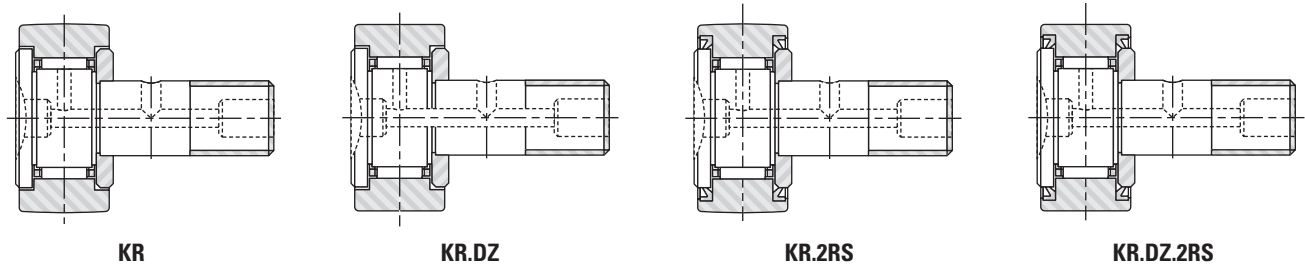

Fig. B-49. Stud-type track rollers, caged needle rollers

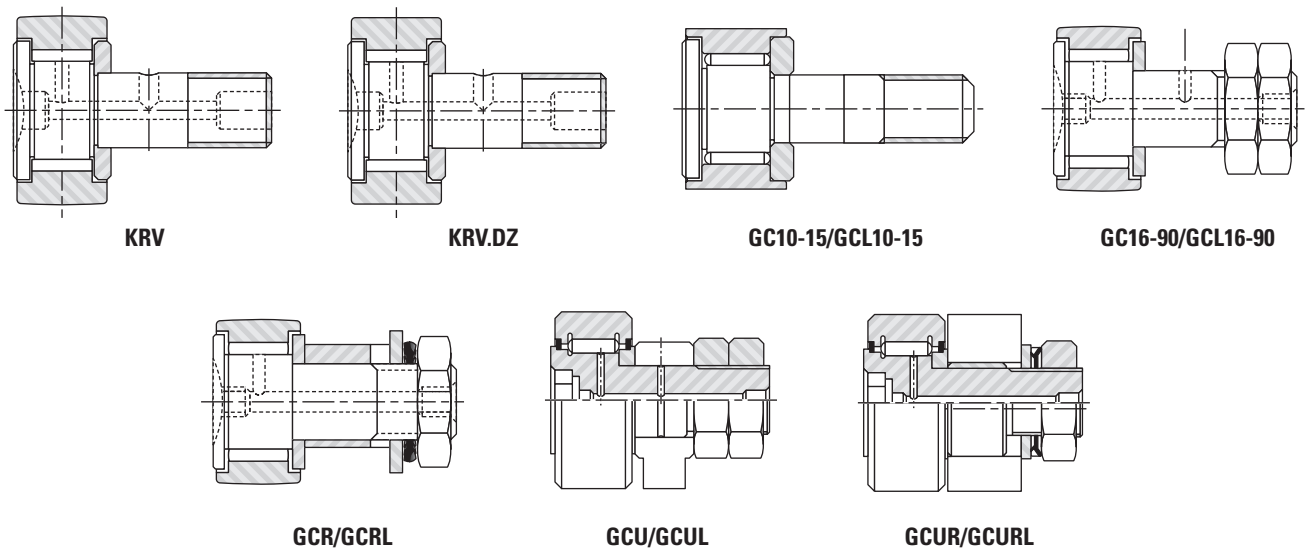

Fig. B-50. Stud-type track rollers, full complement needle rollers

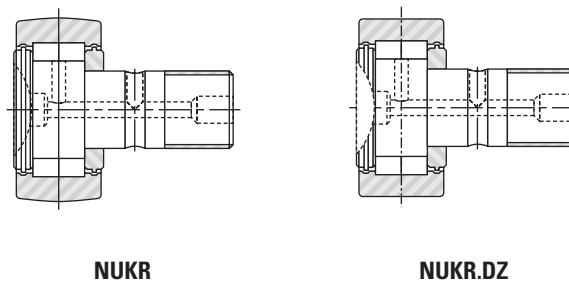

Fig. B-51. Stud-type track rollers, full complement cylindrical rollers





TYPES OF METRIC SERIES YOKE-TYPE TRACK ROLLERS

B

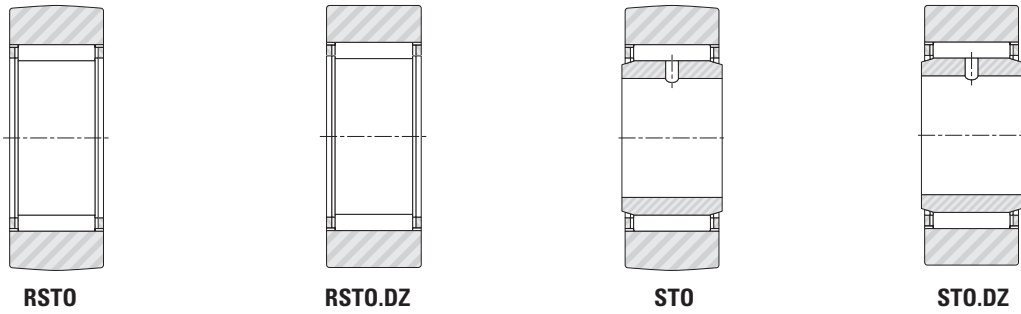

Fig. B-52. Yoke-type track rollers without end washers

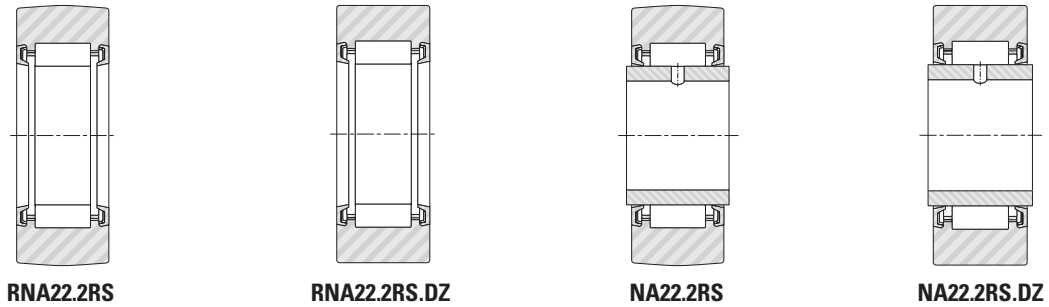

Fig. B-53. Sealed yoke-type track rollers without end washers

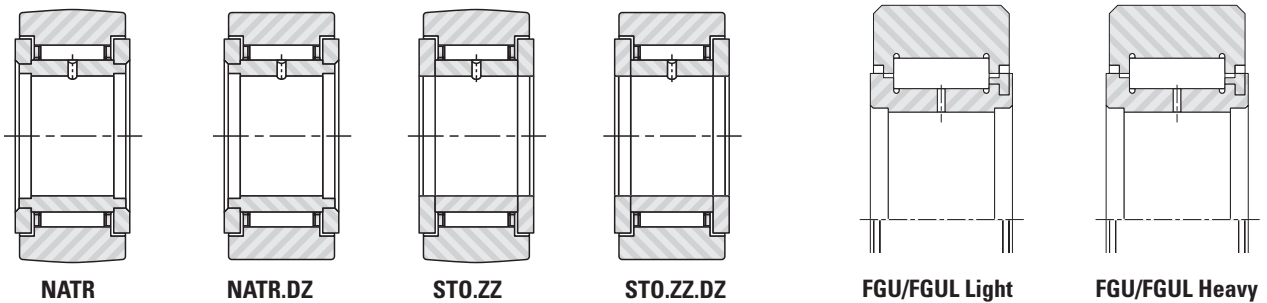

Fig. B-54. Yoke-type track rollers with end washers

Fig. B-55. Yoke-type track rollers with full complement of cylindrical rollers

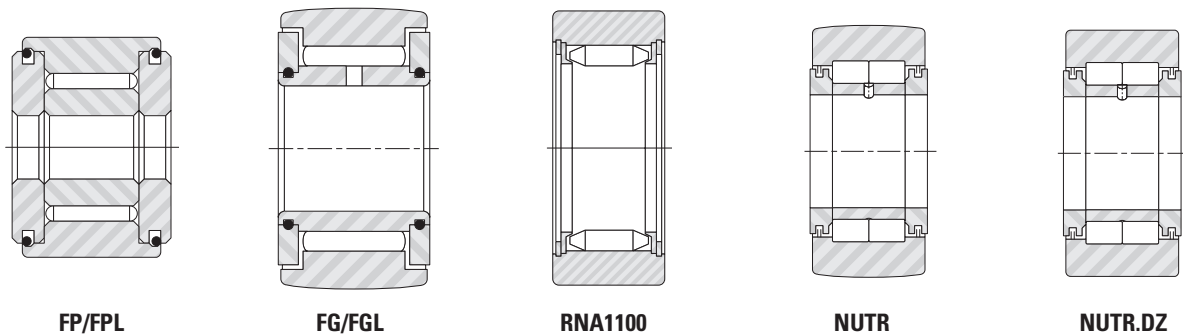

Fig. B-56. Yoke-type track rollers with end washers, full complement of needle rollers

CONSTRUCTION

STUD-TYPE TRACK ROLLERS

The metric series stud-type track roller is a non-separable unit – consisting of a large radial cross section outer ring, radial needle roller and cage assembly, or a full complement of needle or cylindrical rollers, a stud and a retaining washer securely fastened to the stud.

The seals on the sealed stud-type track rollers are located in the counterbores of the outer ring and seal against the stud flange and the retaining washer, providing good retention of lubricant and exclusion of foreign material. The seals are thermally stable in a temperature range between -30° C and 110° C (-25° F and 225° F).

A screwdriver slot (standard) or a hexagonal wrench socket (customer requested) in the head of the stud facilitates mounting. Wrench sizes are listed on the dimensional tables where found among certain GC Series sizes, beginning on page B-228. Other metric series hexagonal socket sizes are listed in Table B-29.

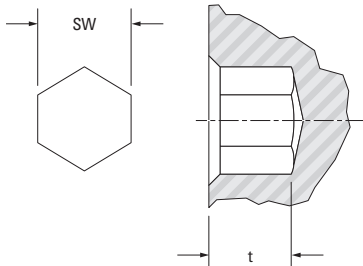

Fig. B-57. Hexagonal socket – metric series.

Table B-29. Hexagonal socket wrench sizes

Stud-type track roller O.D.			
>	≤	SW	t
mm in.	mm in.	mm in.	mm in.
-	16.000	3.000	2.500
-	0.6299	0.1181	0.0984
19.000	26.000	4.000	2.500
0.7480	1.0236	0.1575	0.0984
30.000	35.000	6.000	4.000
1.1811	1.3779	0.2362	0.1575
40.000	52.000	8.000	5.000
1.5748	2.0472	0.3150	0.1968
62.000	72.000	12.000	7.000
2.4409	2.8346	0.4724	0.2756
80.000	90.000	17.000	10.000
3.1496	3.5433	0.6693	0.3937

ECCENTRIC STUDS FOR STUD-TYPE TRACK ROLLERS

To provide radial adjustment of the outer ring toward the track or cam surface at the time of installation, some metric series stud-type track rollers are available with eccentric studs – specified by adding the letter “E” to the designation letters: KRE and NUKRE. The GCR and GCUR Series include an eccentric bushing added to the track roller stud. Appropriate dimensions of the eccentric stud bushing are listed in Table B-30 and Table B-31 on page B-216.

Since a track roller with an eccentric stud is usually adjusted upon installation by turning the stud in the mounting hole, a close clearance fit between the outer diameter of the bushing and the mounting hole is necessary. For turning the stud, a hexagonal wrench is generally more convenient than a screwdriver. Thus, the option of a hexagonal wrench socket in the head of the stud should be exercised.

Some applications may require more secure positioning than provided by the tightened stud nut. If so, it is recommended that the mounting hole and the eccentric bushing be drilled at the time of installation to accept a locating dowel pin.

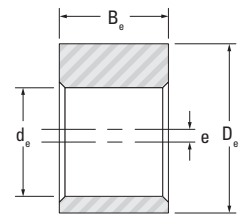

Fig. B-58. Eccentric bushing dimensions – metric series (except GCR, GCUR series)

Table B-30. Eccentric bushing dimensions – metric series (except GCR, GCUR series)

Stud-type track roller O.D.		d _e	D _e	B _e	e
>	≤	Eccentric bushing dimensions			
mm in.	mm in.	mm in.	mm in.	mm in.	mm in.
19.000	19.000	8.000	11.000	9.000	0.500
07480	0.7480	0.3150	0.4331	0.3543	0.0197
22.000	26.000	10.000	13.000	10.000	0.500
0.8661	1.10236	0.3937	0.5118	0.3937	0.0197
30.000	32.000	12.000	15.000	11.000	0.500
1.1811	1.2598	0.4724	0.5905	0.4331	0.0197
35.000	35.000	16.000	20.000	14.000	1.000
1.3779	1.3779	0.6299	0.7874	0.5512	0.0394
40.000	40.000	18.000	22.000	16.000	1.000
1.5748	1.5748	0.7087	0.8661	0.6299	0.0394
47.000	52.000	20.000	24.000	18.000	1.000
1.8504	2.0472	0.7874	0.9449	0.7087	0.0394
62.000	72.000	24.000	28.000	22.000	1.000
2.4409	2.8346	0.9449	1.1024	0.8661	0.0394
80.000	90.000	30.000	35.000	29.000	1.500
3.1496	3.5433	1.1811	1.3779	1.1417	0.0591



Table B-31. Eccentric bushing dimensions metric series GCR and GCUR

Stud-type track roller O.D.		d _e	D _e	B _e	e
Over	Incl.	Eccentric bushing dimensions			
mm in.	mm in.	mm in.	mm in.	mm in.	mm in.
-	19.000	6.000	9.000	7.500	0.500
-	0.7480	0.2362	0.3543	0.2953	0.0197
19.000	28.000	10.000	14.000	10.500	1.000
07480	1.1024	0.3937	0.5512	0.4134	0.0394
28.000	32.000	12.000	16.000	11.500	1.000
1.1024	1.2598	0.4724	0.6299	0.4528	0.0394
32.000	35.000	16.000	21.000	15.100	1.500
1.2598	1.3779	0.6299	0.8268	0.5945	0.0591
35.000	40.000	18.000	24.000	17.100	1.500
1.3779	1.5748	0.7087	0.9449	0.6732	0.0591
40.000	52.000	20.000	27.000	19.100	2.000
1.5748	2.0472	0.7874	1.0630	0.7520	0.0787
52.000	72.000	24.000	36.000	24.100	3.000
2.0472	2.8346	0.9449	1.4173	0.9488	0.1181
72.000	90.000	30.000	42.000	30.700	3.000
2.8346	3.5433	1.1811	1.6535	1.2087	0.1181
90.000	110.000	36.000	48.000	36.500	3.000
3.5433	4.3307	1.4173	1.8898	1.4370	0.1181
110.000	-	42.000	54.000	43.500	3.000
4.3307	-	1.6535	2.1260	1.7126	0.1181

METRIC SERIES YOKE-TYPE TRACK ROLLERS WITHOUT END WASHERS

These yoke-type track rollers are available with a profiled or a cylindrical outer diameter of the outer ring, and with or without a separable inner ring. Since they are supplied without end washers, their outer rings must be guided by the adjacent end locating surfaces. Tolerance class F6 is the normal specification for the bore of the metric series radial needle roller and cage assemblies used with these yoke-type track rollers.

YOKE-TYPE TRACK ROLLERS – SERIES RSTO AND STO

Series STO have a separable inner ring and when the inner ring is removed they become series RSTO. They run directly on a hardened and ground inner raceway. Quality requirements for inner raceways are given in the engineering section of this catalog.

SEALED YOKE-TYPE TRACK ROLLERS WITHOUT END WASHERS – SERIES RNA 22.2RS AND NA22.2RS

These yoke-type track rollers have the same bore diameter and outer diameter as most of the other metric series yoke-type track rollers listed in this catalog. The thick section outer ring is made of one-piece channel-shaped bearing-quality steel – heat-treated to yield maximum load-carrying capability. The integral end flanges provide axial guidance for the large diameter needle rollers, and a cage supplies their inward retention. These track rollers have two integral lip contact seals designated by .2RS. The seals are thermally stable in a temperature range between -30° C and 110° C

(-25° F and 225° F). Care should be exercised when mounting track rollers without inner rings onto inner raceways, to avoid damage to the seals.

METRIC SERIES YOKE-TYPE TRACK ROLLERS WITH END WASHERS

These yoke-type track rollers are available with a crowned or a cylindrical outer diameter to the outer ring. Metric series yoke-type track rollers with end washers – depending on the internal construction – may be end guided, either through the end washers or between the end faces of the rollers and the inside faces of the outer ring flanges.

YOKE-TYPE TRACK ROLLERS – SERIES NATR AND STO.ZZ

The series NATR yoke-type track rollers are of non-separable design, consisting of a crowned or a cylindrical outer ring, caged needle rollers, an inner ring and two retaining end washers securely fastened to the inner ring. The series STO.ZZ yoke-type track rollers are of separable design with two loose end washers. These end washers, placed in the counter bores of the outer ring, form very effective labyrinth-type shields, providing good retention of lubricant and exclusion of foreign material. A lubrication hole in the inner ring enables re-lubrication when a cross-drilled bolt or shaft – which can be serviced from the end – is used.

YOKE-TYPE TRACK ROLLERS – SERIES NUTR

The series NUTR yoke-type track rollers are of non-separable design consisting of a crowned or cylindrical outer ring, two rows of full complements of cylindrical rollers, an inner ring, two retaining end washers and two shields. The outer ring is located axially through the cylindrical rollers.

A lubricating hole in the inner ring enables re-lubrication when a cross-drilled bolt or shaft, which can be serviced from the end, is used.

The smallest track roller of this series has an outer diameter of 35.000 mm (1.3780 in.). NUTR yoke-type track rollers are well-suited to carry high loads and designs with a thicker outer ring and particularly suitable for high shock loads. Designs with thicker outer rings have a larger outer diameter which can be identified by the bearing designation (e.g., NUTR 1542).

YOKE-TYPE TRACK ROLLERS – SERIES FP AND FG

The FP and FG non-separable inner ring designs are available in crowned or cylindrical outer rings. Both employ a full complement of needle rollers and require re-lubrication via a pathway through the shaft. The FP Series is the smallest series available and is not offered with seals.



YOKE-TYPE TRACK ROLLERS – SERIES FGU (LIGHT AND HEAVY TYPES)

The FGU non-separable inner ring designs are available in crowned or cylindrical outer rings. All FGU series use a full complement of cylindrical rollers between the inner and outer rings and require re-lubrication via a pathway through the shaft. The FGU heavy series uses a thicker outer ring section and is capable of higher loads.

Both FGU series are only available with a metal shield for a roller sealing option.

YOKE-TYPE TRACK ROLLERS – SERIES RNA, RNAB, RNAL

The RNA and RNAB Series design uses a full complement of needle rollers retained with a pair of end washers. A separate, matching inner ring is listed in the tables of part numbers. The RNAL Series uses a cylindrical outer ring and is only offered in limited sizes.

DIMENSIONAL ACCURACY

The tolerances of the basic metric series caged roller and NUKR stud-type and yoke-type track rollers, whose outer rings have a cylindrical outer diameter, correspond to tolerances specified in ISO 492 Radial bearings tolerances. The outer ring tolerances given in Table B-32 apply to the outer rings used in the caged roller and NUKR stud-type and caged roller and NUTR yoke-type, metric series, track rollers. Metric series track rollers with a crowned outer diameter are the exception – their outer diameter tolerance is 0-0.05 for all caged roller sizes and NUTR, NUKR types. The remaining types

have h9 tolerance on profiled outer diameters and h7 for straight diameters. Stud diameter and stud length tolerances are given in Table B-33. The inner ring tolerances, given in Table B-34 on page B-218, apply to inner rings used in metric series caged roller, NUKR Series yoke-type track rollers.

MOUNTING STUD-TYPE TRACK ROLLERS

When the stud shank of a metric series stud-type track roller is mounted in a hole of tolerance H7, the installation force should be applied only to the center portion of the flanged end of the stud – preferably with an arbor press. The surface of the hole in the machine element which supports the stud must not deform under the expected load. And the support should be sufficiently rigid to resist bending loads. Deformation and bending will cause uneven loading of the outer ring.

Table B-33. Tolerances for stud diameter and stud length – metric series

d ₁		Δd _{1S}		B ₂	ΔB ₂	
Stud diameter		Stud length				
>	≤	Max.	Min.		Max.	Min.
mm		μm		mm		
3	6	0	-12	all lengths	0	-1
6	10	0	-15			
10	18	0	-18			
18	30	0	-21			
30	50	0	-25			
50	80	0	-30			
80	100	0	-35			

Table B-32. Outer ring – metric series (caged roller and NUKR, NUTR types)

D		ΔD _{mp}				ΔC _s		K _{ea}
>	≤	Cylindrical		Crowned		Max.	Min.	Max.
mm in.	mm in.	mm in.	mm in.	mm in.	mm in.	mm in.	mm in.	mm in.
10.000 0.3937	18.000 0.7087	0.000 0.0000	-0.008 -0.0003	0.000 0.0000	-0.050 -0.0020	0.000 0.0000	-0.120 -0.0047	0.015 0.0006
18.000 0.7087	30.000 1.1811	0.000 0.0000	-0.009 -0.00035	0.000 0.0000	-0.050 -0.0020	0.000 0.0000	-0.120 -0.0047	0.015 0.0006
30.000 1.1811	50.000 1.9685	0.000 0.0000	-0.011 -0.0004	0.000 0.0000	-0.050 -0.0020	0.000 0.0000	-0.120 -0.0047	0.020 0.0008
50.000 1.9685	80.000 3.1496	0.000 0.0000	-0.013 -0.0005	0.000 0.0000	-0.050 -0.0020	0.000 0.0000	-0.120 -0.0047	0.025 0.0010
80.000 3.1496	120.000 4.7244	0.000 0.0000	-0.015 -0.0006	0.000 0.0000	-0.050 -0.0020	0.000 0.0000	-0.120 -0.0047	0.035 0.0014
120.000 4.7244	150.000 5.9055	0.000 0.0000	-0.018 -0.0007	0.000 0.0000	-0.050 -0.0020	0.000 0.0000	-0.120 -0.0047	0.040 0.0016
150.000 5.9055	180.000 7.0866	0.000 0.0000	-0.025 -0.0010	0.000 0.0000	-0.050 -0.0020	0.000 0.0000	-0.150 -0.0059	0.045 0.0018
180.000 7.0866	240.000 9.4488	0.000 0.0000	-0.030 -0.0012	0.000 0.0000	-0.050 -0.0020	0.000 0.0000	-0.200 -0.0079	0.050 0.0020





Table B-34. Inner ring – metric series (caged roller types)

Tolerances in μm (0.001 mm)

d		Δ_{dmp}		Δ_{Bs}	
>	\leq	Max.	Min.	Max.	Min.
mm in.	mm in.	mm in.	mm in.	mm in.	mm in.
2.500 0.0984	18.000 0.7087	0.000 0.0000	-0.008 -0.0003	0.000 0.0000	-0.180 -0.0071
18.000 0.7087	30.000 1.1811	0.000 0.0000	0.010 -0.0004	0.000 0.0000	-0.210 -0.0083
30.000 1.1811	50.000 1.9685	0.000 0.0000	-0.012 -0.0005	0.000 0.0000	-0.250 -0.0098
50.000 1.9685	80.000 3.1496	0.000 0.0000	-0.015 -0.0006	0.000 0.0000	-0.300 -0.0118
80.000 3.1496	120.000 4.7244	0.000 0.0000	-0.020 -0.0008	0.000 0.0000	-0.350 -0.0138

In mounting the stud-type track roller, the retaining washer must be firmly backed up by a flat shoulder which is square with the stud center line. The shoulder diameter must be no smaller than the minimum clamping diameter, d_a listed in the bearing tables.

The maximum inherent strength of the stud is obtained when the track roller is supported, as close as possible, to the retaining washer – which minimizes the bending moment. For this reason the edge of the housing – which supports the stud shank – should be kept as sharp as practical but free from burrs.

The clamping nut should not be tightened with a torque value higher than the maximum listed. A screwdriver slot, or hexagonal wrench socket in the flanged end of the stud, is provided for a tool to prevent the stud from turning when the nut is being tightened. Since the bottom of the screwdriver slot is not flat, it is helpful to put a radius on the tip of the screwdriver being used to hold the stud more securely. Hexagonal nuts are supplied with all metric series stud-type track rollers.

YOKE-TYPE TRACK ROLLERS

The machine element with the holes in which the mounting bolt or shaft is supported must be sufficiently rigid to resist local crushing under the applied load and to resist bending which can cause uneven loading of the needle rollers.

When applied loads are high, the h6 or j6 tolerance should be used in conjunction with a high strength shaft or bolt for mounting metric series yoke-type track rollers. When loads are moderate, a g6 tolerance may be used with a high strength shaft or bolt. For light loads, the loose transition fit with the f6 tolerance may be used with an unhardened shaft or bolt.

The yoke-type track rollers with inner rings – including those with end washers as well as inner rings – should be clamped endwise between parallel faces, perpendicular to the axis to prevent the retaining washers from coming off under load. The dimensions of machine parts, adjoining the metric series yoke-type track rollers, should be based on the minimum clamping diameter d_a to ensure that the washers are adequately supported. If the track roller cannot be end clamped, a close axial fit in the yoke is required. Care should be taken to assure that the lubricating hole is located in the unloaded zone of the raceway.

The metric series yoke-type track rollers without inner rings require a hardened and ground shaft, or bolt with a k5 tolerance. Inner raceway quality requirements are given in the engineering section.

LOAD RATINGS

DYNAMIC LOADING AS A TRACK ROLLER

When the outer ring of a stud-type or yoke-type track roller runs on a track, the contact – under a radial load – causes elastic (oval) deformation of the outer ring. As a result, a smaller zone of the raceway is loaded and the load is distributed on fewer needle rollers. This, in turn, affects the dynamic and static load ratings of the track rollers. Also, this deformation generates bending stress in the outer ring which must not exceed the maximum permitted for the material of the outer ring. The maximum permissible dynamic ($F_{r\text{perm}}$) radial load condition is determined by this requirement.

The rating life of stud-type or yoke-type track rollers should be calculated using the dynamic load ratings, C_w , shown in the following tables. The tables also show the maximum permissible radial load, $F_{r\text{perm}}$, that can be dynamically applied on stud-type or yoke-type track rollers. However, to calculate the L_{10} life of a track roller, the applied radial load must not be greater than $C_w/2$ based on ideal operating conditions of alignment, lubrication, temperature, speed and accelerations.

Example:

Given: A track roller application for a linear slide in which each roller supports a 453.59 kg (1000 lbs.) load and travels at 609.600 mm (24.0000 in.) per second.

Select a track roller and calculate the L_{10} life in hours assuming continuous operation at the given speed. Assume conditions of alignment, lubrication and temperature are ideal.

Solution: Calculate the minimum C_w required.

The applied radial load must not be greater than $C_w/2$ based on ideal operating conditions.

$$\text{Therefore, } Fr < C_w/2 \text{ or } C_w > 907.18 \text{ kN (2000 lbs.)}$$

$$\text{For a KRV30, } C_w = 1002.4 \text{ kN (2210 lbs.)}$$

To calculate the speed in min^{-1} , $V = \text{Pi} \cdot D \cdot n$

Where:

- V = linear velocity
- Pi = 3.14
- D = outside diameter of the track roller assembly

$$\text{Therefore, } 609.600 \text{ mm (24.000 in.)/sec.} = 3.14 \cdot 30.000 \text{ mm} \cdot n$$

Making appropriate substitutions and solving for n yields a value of approximately 388 min^{-1} .

The standard catalog life equation of a roller bearing is:

$$L_{10} = (C/P)^{10/3} \cdot (16667/n)$$

Where:

- L_{10} = calculated fatigue life in hours
- C = the dynamic radial load ratings based on 1000000 revolutions
- P = the dynamic equivalent radial load
- n = speed in min^{-1}

Substituting C_w for C and solving:

$$L_{10} = (2210/1000)^{10/3} \cdot (16667/388) = 604 \text{ hours}$$

STATIC RATING AS A TRACK ROLLER

In addition to the basic static load rating, C_0 , the tables also list the maximum permissible static radial load, $F_{0r \text{ perm}}$, that may be applied to a stud-type or yoke-type metric series track roller. The values of $F_{0r \text{ perm}}$ result in a calculated minimum static factor f_s of 0.7 for the worst condition of internal load distribution in metric series track roller operation. **The $F_{0r \text{ perm}}$ values must not be exceeded.** Exceeding $F_{0r \text{ perm}}$ may cause permanent damage to the track roller. A damaged track roller could cause the equipment in which the track roller is installed to malfunction. The static factor f_s can be calculated using the following formula:

$$f_s \geq 0.7 \left(\frac{F_{0r \text{ perm}}}{P_{0r}} \right)$$

Where:

- $F_{0r \text{ perm}}$ = Maximum permissible static radial load
- P_{0r} = Equivalent static load
(F_{0r} for yoke-type track rollers)
- F_{0r} = Static radial load
- f_s = Static factor whose values should not be smaller than those suggested in Table B-35.

Table B-35. Suggested values for static factors f_s for metric series track rollers

Requirements for yoke – type track rollers and stud – type track rollers	Suggested f_s values	
	Max.	Min.
High shock-type loads Quiet running	2.5	1.5
Normal loading Normal quietness of running	1.5	1
Minor impact loads and rotary motion particularly quiet running not required	1	0.7





LUBRICATION OF STUD-TYPE TRACK ROLLERS

JTEKT metric series stud-type track rollers are supplied with a lithium soap-based, general-purpose grease. When the caged KR Series track rollers are operated at low speeds, with light loads and in clean environments, there is often no need to re-lubricate the track roller. In other applications, periodic re-lubrication may be necessary to obtain optimum performance. The full complement series of track rollers have less internal volume available for grease storage. Therefore, they may require more frequent lubrication than caged-type track rollers. Stud-type track rollers – with a screwdriver slot in the flanged end of the stud – have provisions for re-lubrication through the flanged end of the stud. Metric series stud-type track rollers, with hexagonal sockets, can not be re-lubricated from the flanged end of the stud. Both types of metric series stud-type track rollers – with outer diameters larger than 22.000 mm (0.8661 in.) (28.000 mm [1.1024 in.] for all GC variations) – allow for re-lubrication through the threaded end of the stud. In addition, caged roller and NUKR Series stud-type track rollers – with 30.000 mm (1.8110 in.) and larger outer diameters – allow for re-lubrication through a cross-drilled hole in the stud shank. The ends of the axial holes are counterbored to accept press-fit grease fittings of series VENN. The grease fittings are supplied with metric series stud-type track rollers. Hole diameters (d_4) for these grease fittings are listed in the tables of dimensions on pages later in this chapter as it applies. Note that the GC small series has no axial hole.

One or more plugs are supplied with every metric series stud-type track roller, to close off unused holes. At the flanged end, the plug must not be pushed in too deeply, as it may cover the cross-drilled lubricating hole. The plug should be pressed in using an installation tool whose dimensions are given in Table B-37. If the cross-drilled hole in the stud shank is not used, it will be covered when the track roller is properly installed.

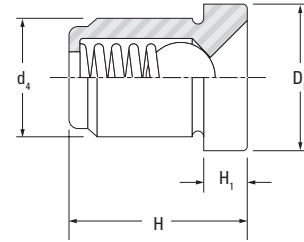

Fig. B-59. Metric series grease fittings

Table B-36. Metric series grease fittings, series VENN

Designation	d_4 mm in.	D_k mm in.	H mm in.	H_1 mm in.	Approx. wt. g lbs.
VENN 4	4.000 0.1575	6.000 0.2362	6.000 0.2362	1.500 0.0591	0.4 0.0009
VENN 6	6.000 0.2362	8.000 0.3147	7.000 0.2756	2.000 0.0787	1.6 0.0035
VENN 8	8.000 0.3150	10.000 0.3937	12.000 0.4724	3.000 0.1181	4.7 0.0104

During installation of the track roller it is desirable to ensure that the cross-drilled hole is positioned in the unloaded zone of the track roller raceway. The location of the cross-drilled hole can be best recognized by its alignment with the manufacturer's stamp, parallel to the screwdriver slot (when applicable).

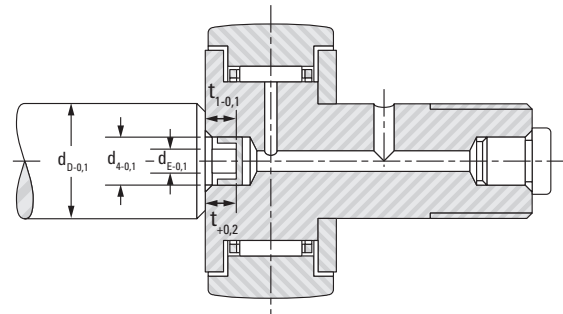

Fig. B-60. Installation tool for metric series plug

Table B-37. Installation tool for metric series plug

Stud-type track roller O.D.		d_4	d_D	d_E	t	t_1
>	≤	mm in.	mm in.	mm in.	mm in.	mm in.
16.000 0.6299	26.000 1.0236	3.900 0.1535	10.000 0.3937	2.700 0.1063	3.700 0.1457	4.500 0.1772
30.000 1.1811	40.000 1.5748	5.900 0.2323	12.000 0.4724	4.700 0.1850	4.700 0.1850	7.000 0.2756
47.000 1.8504	90.000 3.5433	7.900 0.3110	15.000 0.5905	6.700 0.2638	6.700 0.2638	10.000 0.3937

LUBRICATION OF YOKE-TYPE TRACK ROLLERS

Yoke-type track rollers are produced with a lubricating hole in the inner ring so they can be re-lubricated through a cross-drilled hole in the supporting shaft or bolt. When mounting yoke-type track rollers, care should be taken that the lubrication hole is located in the unloaded raceway zone.

Oil is the preferred lubricant for yoke-type track rollers. Continuous oil lubrication, or frequent grease lubrication should be used for steady rotating conditions. Applications involving slow, intermittent oscillations are not as critical, and longer intervals between re-lubrication are permitted. Sealed yoke-type track rollers are normally supplied with an initial charge of a medium-temperature grease. Caged yoke-type track rollers have maximum grease storage capacity and, consequently, longer pregreased life than full complement types.





**NEEDLE ROLLER AND CAGE ASSEMBLIES,
STUD-TYPE (KR SERIES)
METRIC SERIES**

B

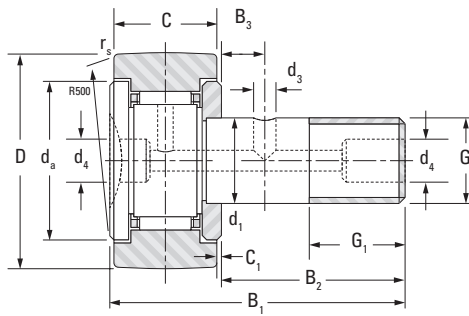

KR

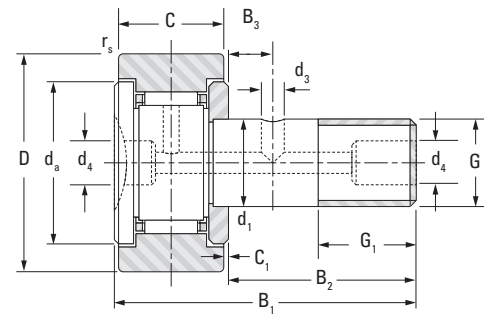

KR.DZ

Outer Dia.	h7	D	C	r _s min	B ₁	B ₂	B ₃	G ₁	d ₄	d ₃	G	C ₁	d _a
											Thread		
16 0.6299	6 0.2362	16 0.6299	11 0.433	0.3 0.012	28.2 1.110	16 0.630		8 0.315	4 0.157		M6x1	0.6 0.024	11 0.433
19 0.7480	8 0.3150	19 0.7480	11 0.433	0.3 0.012	32.2 1.268	20 0.787		10 0.394	4 0.157		M8x1.25	0.6 0.024	13 0.512
22 0.8661	10 0.3937	22 0.8661	12 0.472	0.3 0.012	36.0 1.417	23 0.906		12 0.472	4 0.157		M10x1	0.6 0.024	15 0.591
26 1.0236	10 0.3937	26 1.0236	12 0.472	0.3 0.012	36.0 1.417	23 0.906		12 0.472	4 0.157		M10x1	0.6 0.024	15 0.591
30 0.551	12 0.4724	30 1.1811	14 0.551	0.6 0.024	40.0 1.575	25 0.984	6 0.236	13 0.512	6 0.236	3 0.118	M12x1.5	0.6 0.024	21 0.827
32 0.551	12 0.4724	32 1.2598	14 0.551	0.6 0.024	40.0 1.575	25 0.984	6 0.236	13 0.512	6 0.236	3 0.118	M12x1.5	0.6 0.024	21 0.827



Crowned Designation	Cylindrical Designation	Load Ratings					Tightening Torque	Speed Rating Grease	Wt.
		As a Bearing		As a Track Roller					
		Dynamic	Static	Dynamic		Static			
		C	C ₀	C _w	F _{r perm}	F _{0r perm}			
		kN lbf.		kN lbf.			N-m lb-in.	min ⁻¹	kg lbs.
KR16	KR16.DZ	3.60 810	3.58 800	2.97 670	2.85 640	3.58 800	7 62.0	17000	0.019 0.042
KR19	KR19.DZ	4.18 940	4.65 1050	3.28 740	3.29 740	4.22 950	16 142	13000	0.031 0.068
KR22	KR22.DZ	5.35 1200	6.79 1530	3.94 890	4.04 910	5.45 1230	28 248	10000	0.046 0.101
KR26	KR26.DZ	5.35 1200	6.79 1530	4.55 1020	6.78 1520	7.24 1630	28 248	10000	0.059 0.130
KR30	KR30.DZ	7.89 1770	9.79 2200	6.32 1420	7.74 1740	9.31 2090	45 398	8200	0.087 0.192
KR32	KR32.DZ	7.89 1770	9.79 2200	6.65 1490	9.62 2160	10.3 2320	45 398	8200	0.095 0.209





**NEEDLE ROLLER AND CAGE ASSEMBLIES, SEALED,
STUD-TYPE (KR...2S SERIES)**

METRIC SERIES

B

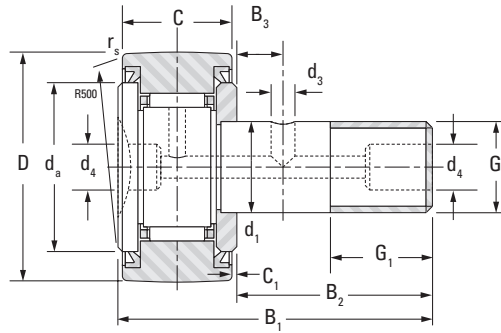

KR.2RS

Outer Dia.	d ₁	D, h7	C	r _s min	B ₁	B ₂	B ₃	G ₁	d ₄	d ₃	G		C ₁	d _a
											Thread			
mm in.	mm in.	mm in.	mm in.	mm in.	mm in.	mm in.	mm in.	mm in.	mm in.	mm in.		mm in.	mm in.	
16 0.6299	6 0.2362	16 0.6299	11 0.433	0.3 0.012	28.2 1.110	16 0.630		8 0.315	4 0.157		M6x1	0.6 0.024	11 0.433	
19 0.7480	8 0.3150	19 0.7480	11 0.433	0.3 0.012	32.2 1.268	20 0.787		10 0.394	4 0.157		M8x1.25	0.6 0.024	13 0.512	
22 0.8661	10 0.3937	22 0.8661	12 0.472	0.3 0.012	36.2 1.425	23 0.906		12 0.472	4 0.157		M10x1	0.6 0.024	15 0.591	
26 1.0236	10 0.3937	26 1.0236	12 0.472	0.3 0.012	36.2 1.425	23 0.906		12 0.472	4 0.157		M10x1	0.6 0.024	15 0.591	
30 1.1811	12 0.4724	30 1.1811	14 0.551	0.6 0.024	40.2 1.583	25 0.984	6 0.236	13 0.512	6 0.236	3 0.118	M12x1.5	0.6 0.024	21 0.827	
32 1.2598	12 0.4724	32 1.2598	14 0.551	0.6 0.024	40.2 1.583	25 0.984	6 0.236	13 0.512	6 0.236	3 0.118	M12x1.5	0.6 0.024	21 0.827	



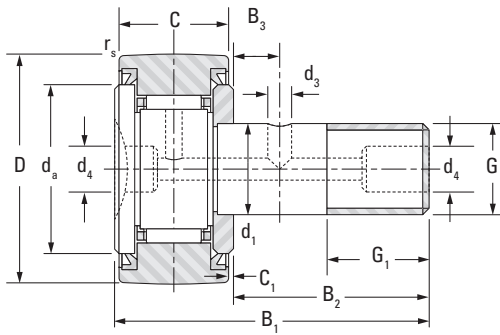

KR.DZ.2RS

Crowned Designation	Cylindrical Designation	Load Ratings					Tightening Torque	Speed Rating Grease	Wt.
		As a Bearing		As a Track Roller					
		Dynamic	Static	Dynamic		Static			
		C	C ₀	C _w	F _{r perm}	F _{0r perm}			
		kN lbf.		kN lbf.			N-m lb-in.	min ⁻¹	kg lbs.
KR16.2RS	KR16.DZ.2RS	3.60 810	3.58 800	2.97 670	2.85 640	3.58 800	7.0 61.96	17000	0.019 0.042
KR19.2RS	KR19.DZ.2RS	4.18 940	4.65 1050	3.28 740	3.29 740	4.22 950	16 141.61	13000	0.031 0.068
KR22.2RS	KR22.DZ.2RS	5.35 1200	6.79 1530	3.94 890	4.04 910	5.45 1230	28 247.82	10000	0.046 0.101
KR26.2RS	KR26.DZ.2RS	5.35 1200	6.79 1530	4.55 1020	6.78 1520	7.24 1630	28 247.82	10000	0.059 0.130
KR30.2RS	KR30.DZ.2RS	7.89 1770	9.79 2200	6.32 1420	7.74 1740	9.31 2090	45 398.28	8200	0.087 0.192
KR32.2RS	KR32.DZ.2RS	7.89 1770	9.79 2200	6.65 1490	9.62 2160	10.3 2320	45 398.28	8200	0.098 0.216





NEEDLE ROLLER BEARINGS

**FULL COMPLEMENT WITH
NEEDLE ROLLERS
(KRV SERIES)
OR CYLINDRICAL
ROLLERS, STUD-TYPE
(NUKR SERIES)**

METRIC SERIES

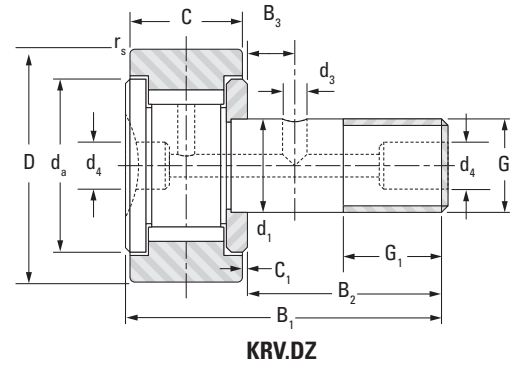
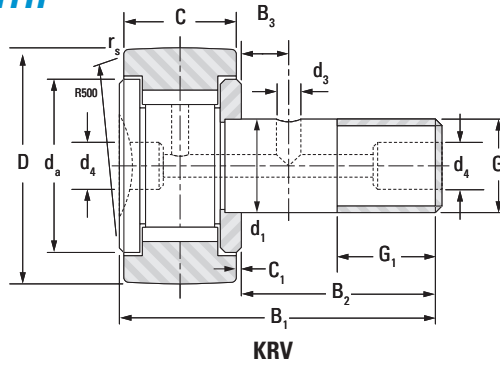

Outer Dia. mm in.	d ₁ mm in.	D, h7 mm in.	C mm in.	r _s min mm in.	B ₁ mm in.	B ₂ mm in.	B ₃ mm in.	G ₁ mm in.	d ₄ mm in.	d ₃ mm in.	G	C ₁ mm in.	d _a mm in.
											Thread		
16 0.6299	6 0.2362	16 0.6299	11 0.433	0.3 0.012	28.2 1.110	16 0.630		8 0.315	4 0.157		M6x1	0.6 0.024	11 0.433
19 0.7480	8 0.3150	19 0.7480	11 0.433	0.3 0.012	32.2 1.268	20 0.787		10 0.394	4 0.157		M8x1.25	0.6 0.024	13 0.512
22 0.8661	10 0.3937	22 0.8661	12 0.472	0.3 0.012	36.2 1.425	23 0.906		12 0.472	4 0.157		M10x1	0.6 0.024	15 0.591
26 1.0236	10 0.3937	26 1.0236	12 0.472	0.3 0.012	36.2 1.425	23 0.906		12 0.472	4 0.157		M10x1	0.6 0.024	15 0.591
30 1.1811	12 0.4724	30 1.1811	14 0.551	0.6 0.024	40.2 1.583	25 0.984	6 0.236	13 0.512	6 0.236	3 0.118	M12x1.5	0.6 0.024	21 0.827
32 1.2598	12 0.4724	32 1.2598	14 0.551	0.6 0.024	40.2 1.583	25 0.984	6 0.236	13 0.512	6 0.236	3 0.118	M12x1.5	0.6 0.024	21 0.827
35 1.3780	16 0.6299	35 1.3780	18 0.709	0.6 0.024	52 2.047	32.5 1.280	8 0.315	17 0.669	6 0.236	3 0.118	M16x1.5	0.8 0.031	25 0.984
40 1.5748	18 0.7087	40 1.5748	20 0.787	1 0.039	58 2.283	36.5 1.437	8 0.315	19 0.748	6 0.236	3 0.118	M18x1.5	0.8 0.031	27 1.063
47 1.8504	20 0.7874	47 1.8504	24 0.945	1 0.039	66 2.598	40.5 1.594	9 0.354	21 0.827	6 0.236	4 0.157	M20x1.5	0.8 0.031	33 1.299
52 2.0472	20 0.7874	52 2.0472	24 0.945	1 0.039	66 2.598	40.5 1.594	9 0.354	21 0.827	6 0.236	4 0.157	M20x1.5	0.8 0.031	37 1.457
62 2.4409	24 0.9449	62 2.4409	29 1.142	1 0.039	80 3.150	49.5 1.949	11 0.433	25 0.984	8 0.315	4 0.157	M24x1.5	0.8 0.031	45 1.772
72 2.8346	24 0.9449	72 2.8346	29 1.142	1.1 0.043	80 3.150	49.5 1.949	11 0.433	25 0.984	8 0.315	4 0.157	M24x1.5	0.8 0.031	51 2.008
80 3.1496	30 1.1811	80 3.1496	35 1.378	1.1 0.043	100 3.937	63 2.480	15 0.591	32 1.260	8 0.315	4 0.157	M30x1.5	1.0 0.039	52 2.047
90 3.5433	30 1.1811	90 3.5433	35 1.378	1.1 0.043	100 3.937	63 2.480	15 0.591	32 1.260	8 0.315	4 0.157	M30x1.5	1.0 0.039	52 2.047

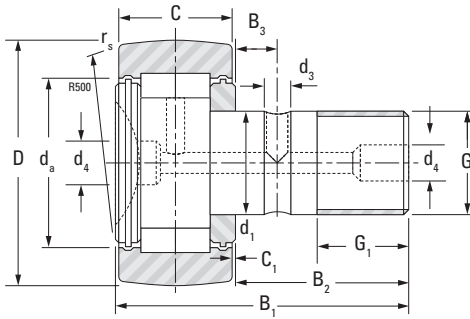

NUKR

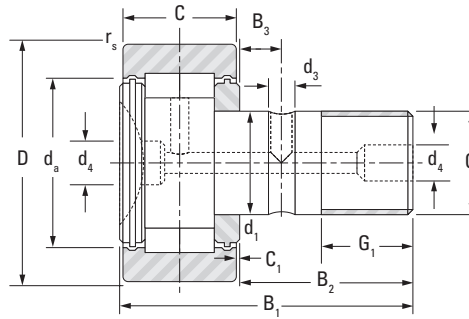

NUKR.DZ

Crowned Designation	Cylindrical Designation	Load Ratings					Tightening Torque	Speed Rating Grease	Wt.
		As a Bearing		As a Track Roller					
		Dynamic	Static	Dynamic		Static			
		C	C ₀	C _w	F _{r perm}	F _{0r perm}			
		kN lbf.		kN lbf.			N-m lb-in.	min ⁻¹	kg lbs.
KRV16	KRV16.DZ	6.90 1550	8.40 1890	5.11 1150	3.49 780	6.28 1410	7 62.0	5700	0.019 0.042
KRV19	KRV19.DZ	8.08 1820	11.0 2470	5.66 1270	4.13 930	7.43 1670	16 142	4300	0.031 0.068
KRV22	KRV22.DZ	9.45 2120	14.3 3210	6.32 1420	5.04 1130	9.07 2040	28 248	3400	0.046 0.101
KRV26	KRV26.DZ	9.45 2120	14.3 3210	7.30 1640	8.60 1930	12.7 2860	28 248	3400	0.059 0.130
KRV30	KRV30.DZ	13.4 3010	19.8 4450	9.85 2210	9.20 2070	15.7 3530	45 398	2800	0.087 0.192
KRV32	KRV32.DZ	13.4 3010	19.8 4450	10.4 2340	11.3 2540	17.4 3910	45 398	2800	0.098 0.216
NUKR35.2SK		24.7 5550	29.4 6610	16.2 3640	10.1 2270	16.1 3620	53.2 471	6100	0.170 0.375
NUKR40.2SK		26.6 5980	33.3 7490	18.7 4200	15.0 3370	23.9 5370	77.5 686	5300	0.250 0.551
NUKR47.2SK		41.4 9310	53.2 12000	28.1 6320	20.5 4610	32.7 7350	109 965	4500	0.380 0.838
NUKR52.2SK		45.8 10300	63.1 14200	29.6 6650	22.2 4990	35.4 7960	109 965	3700	0.461 1.016
NUKR62.2SK		62.7 14100	83.1 18700	40.9 9190	29.6 6650	47.2 10600	193 1708	3200	0.790 1.742
NUKR72.2SK		68.9 15500	97.8 22000	46.1 10400	39.6 8900	63.1 14200	193 1708	2600	1.040 2.293
NUKR80.2SK		95.4 21400	130 29200	69.7 15700	63.2 14200	101 22700	390 3452	2900	1.550 3.417
NUKR90.2SK		95.4 21400	130 29200	77.8 17500	97.8 22000	128 28800	390 3452	2900	2.020 4.453





**FULL COMPLEMENT, SMALL SERIES,
UNSEALED,
STUD-TYPE (GC SERIES)
METRIC SERIES**

B

GC: crowned outer ring
GCL: cylindrical outer ring

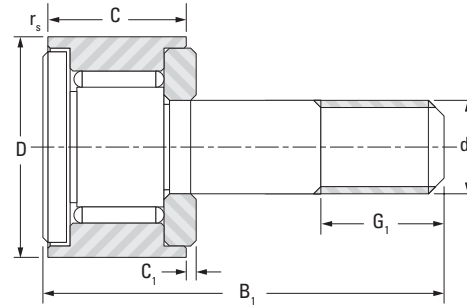

GC10-15/GCL10-15 Series

Outer Dia.	D	d ₁	Thread	C	C ₁	r _s min	B ₁	G ₁
mm in.	mm in.	mm in.		mm in.	mm in.	mm in.	mm in.	mm in.
10 0.3937	10 0.3937	4 0.1575	M4 x 0.7	8 0.315	0.25 0.010	0.2 0.008	19.5 0.768	6 0.236
11 0.4331	11 0.4331	4 0.1575	M4 x 0.7	8 0.315	0.25 0.010	0.2 0.008	19.5 0.768	6 0.236
12 0.4724	12 0.4724	5 0.1969	M5 x 0.8	9 0.354	0.25 0.010	0.2 0.008	22.5 0.886	7 0.276
13 0.5118	13 0.5118	5 0.1969	M5 x 0.8	9 0.354	0.25 0.010	0.2 0.008	22.5 0.886	7 0.276
14 0.5512	14 0.5512	6 0.2362	M6 x 1	9.5 0.374	0.25 0.010	0.3 0.012	26 1.024	8 0.315
15 0.5906	15 0.5906	6 0.2362	M6 x 1	9.5 0.374	0.25 0.010	0.3 0.012	26 1.024	8 0.315

Crowned Designation	Cylindrical Designation	Tightening Torque	Load Ratings					Speed Rating Grease	Wt.
			As a Bearing		As a Track Roller				
			C	C ₀	C _w	F _{r perm}	F _{0r perm}		
N·m lb-in.	kN lbf.		kN lbf.			min ⁻¹	kg lbs.		
GC 10	GCL 10	0.9 7.97	2.80 629	3.09 695	1.92 432	1.01 227	1.82 409	8500	0.006 0.014
GC 11	GCL 11	0.9 7.97	2.8 629	3.09 695	2.12 477	1.43 321	2.58 580	8500	0.007 0.016
GC 12	GCL 12	1.8 15.93	3.74 841	4.74 1070	2.54 571	1.63 366	2.94 661	6600	0.011 0.024
GC 13	GCL 13	1.8 15.93	3.74 841	4.74 1070	2.16 486	2.75 618	3.89 874	6600	0.011 0.024
GC 14	GCL 14	3.0 26.55	4.05 910	5.44 1220	2.86 643	2.26 508	4.07 915	5700	0.016 0.035
GC 15	GCL 15	3.0 26.55	4.05 910	5.44 1220	3.04 683	2.83 636	4.65 1050	5700	0.018 0.039





**FULL COMPLEMENT,
STANDARD SERIES,
WITH OR WITHOUT SEALS,
STUD-TYPE (GC SERIES)
METRIC SERIES**

B

GC: crowned outer ring
GCL: cylindrical outer ring
EE: with plastic seals
EEM: with metal seals

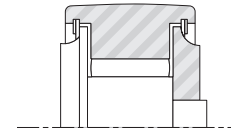
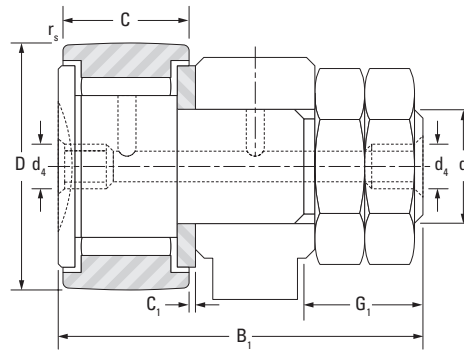

GC...EE, GC...EM

GC16-90/GCL16-90 Series

Outer Dia.	D	d ₁	Pitch	C	C ₁	r _s min	B ₁	G ₁	Crowned Designation	Cylindrical Designation
mm in.	mm in.	mm in.	mm	mm in.	mm in.	mm in.	mm in.	mm in.		
16 0.6299	16 0.6299	6 0.2362	1.0	11 0.433	0.60 0.024	0.3 0.012	28.3 1.114	8 0.315	GC 16	GCL 16
19 0.748	19 0.748	8 0.315	1.25	11 0.433	0.60 0.024	0.3 0.012	32.3 1.272	10 0.394	GC 19	GCL 19
22 0.8661	22 0.8661	10 0.3937	1.25	12 0.472	0.60 0.024	0.3 0.012	36.3 1.429	12 0.472	GC 22	GCL 22
24 0.9449	24 0.9449	10 0.3937	1.25	12 0.472	0.60 0.024	0.3 0.012	36.3 1.429	12 0.472	GC 24	GCL 24
26 1.0236	26 1.0236	10 0.3937	1.25	12 0.472	0.60 0.024	0.3 0.012	36.3 1.429	12 0.472	GC 26	GCL 26
28 1.1024	28 1.1024	10 0.3937	1.25	12 0.472	0.60 0.024	0.3 0.012	36.3 1.429	12 0.472	GC 28	GCL 28
30 1.1811	30 1.1811	12 0.4724	1.5	14 0.51	0.60 0.024	0.6 0.024	40.3 1.587	13 0.512	GC 30	GCL 30
32 1.2598	32 1.2598	12 0.4724	1.5	14 0.51	0.60 0.024	0.6 0.024	40.3 1.587	13 0.512	GC 32	GCL 32
35 1.378	35 1.378	16 0.6299	1.5	18 0.709	0.80 0.031	0.6 0.024	52.3 2.059	17 0.669	GC 35	GCL 35
47 1.8504	47 1.8504	20 0.7874	1.5	24 0.45	0.80 0.031	1 0.039	66.3 2.61	21 0.827	GC 47	GCL 47
52 2.0472	52 2.0472	20 0.7874	1.5	24 0.45	0.80 0.031	1 0.039	66.3 2.61	21 0.827	GC 52	GCL 52
62 2.4409	62 2.4409	24 0.9449	1.5	29 1.142	0.80 0.031	1 0.039	80.3 3.161	25 0.984	GC 62	GCL 62
72 2.8346	72 2.8346	24 0.9449	1.5	29 1.142	0.80 0.031	1 0.039	80.3 3.161	25 0.984	GC 72	GCL 72
80 3.1496	80 3.1496	30 1.1811	1.5	35 1.378	1.00 0.039	1 0.039	100.3 3.949	32 1.26	GC 80	GCL 80
85 3.3465	85 3.3465	30 1.1811	1.5	35 1.378	1.00 0.039	1 0.039	100.3 3.949	32 1.26	GC 85	GCL 85
90 3.5433	90 3.5433	30 1.1811	1.5	35 1.378	1.00 0.039	1 0.039	100.3 3.949	32 1.26	GC 90	GCL 90

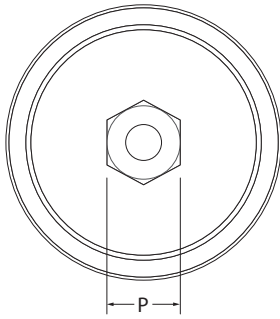

Hex Socket Roller End

Tightening Torque	Load Ratings					Speed Rating Grease	P	d ₄	Wt.
	As a Bearing		As a Track Roller				Wrench		
	C	C ₀	C _w	F _{r perm}	F _{Dr perm}				
N-m lb-in.	kN lbf.		kN lbf.			mm	mm in.	kg lbs.	
3 26.6	5.66 1270	6.51 1460	4.19 942	2.79 627	5.02 1130	5700	N/A	4 0.157	0.021 0.046
8 70.8	6.44 1450	8.15 1830	4.65 1050	3 785	6.28 1410	4400	N/A	4 0.157	0.034 0.075
20 177	7.3 1640	10.2 2290	5.05 1140	4.07 915	7.33 1650	3500	N/A	4 0.157	0.058 0.128
20 177	7.3 1640	10.2 2290	5.45 1230	5.42 1220	8.63 1940	3500	N/A	4 0.157	0.067 0.148
20 177	9.92 2230	12.9 2900	7.09 1590	5.43 1220	9.77 2200	3200	N/A	4 0.157	0.072 0.159
20 177	9.92 2230	12.9 2900	7.57 1700	6.95 1560	11.4 2560	3200	N/A	4 0.157	0.08 0.176
26 230	15.5 3480	20.4 4590	11.2 2520	8.48 1910	15.3 3440	2900	8	4 0.157	0.115 0.254
26 230	15.5 3480	20.4 4590	11.8 2650	10.6 2380	18.1 4070	2900	8	4 0.157	0.12 0.265
64 566	23.6 5310	33.1 7440	15.7 3530	10.8 2430	19.4 4360	2200	10	6 0.236	0.208 0.459
120 1060	36.5 8210	65.5 14700	22.5 5060	20.2 4540	36.4 8180	1400	14	6 0.236	0.477 1.052
120 1060	36.5 8210	65.5 14700	25.2 5670	28 6290	47.5 10700	1400	14	6 0.236	0.542 1.195
220 1950	43.3 9730	85.6 19200	30.5 6860	42.9 9640	64.7 14500	1200	12	6 0.236	0.944 2.081
220 1950	43.3 9730	85.6 19200	33.9 7620	65.8 14800	79.5 17900	1200	12	6 0.236	1.165 2.568
450 3980	65.1 14600	144 32400	42.7 9600	62.9 14100	95.3 21400	870	14	8 0.315	1.915 4.222
450 3980	65.1 14600	144 32400	45.1 10100	75.3 16900	106 23800	870	14	8 0.315	2.096 4.621
450 3980	65.1 14600	144 32400	47.1 10600	88.8 20000	115 25900	870	14	8 0.315	2.287 5.042





**FULL COMPLEMENT,
WITH METAL SEALS,
STUD-TYPE (GCU...MM SERIES)
METRIC SERIES**

B

GCU: crowned outer ring
GCUL: cylindrical outer ring

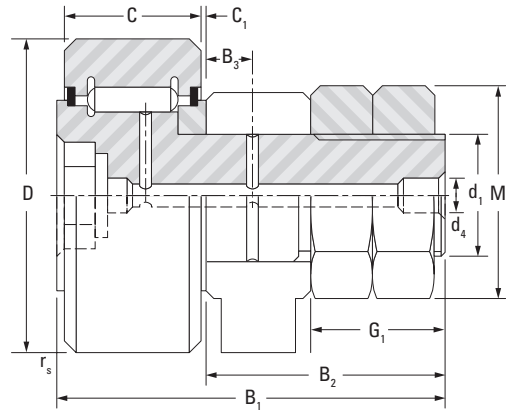

GCU, GCUL

Outer Dia.	D	d ₁	C	C ₁	B ₁	G ₁	r _s min	Crowned Designation	Cylindrical Designation
mm in.	mm in.	mm in.	mm in.	mm in.	mm in.	mm in.	mm in.		
35 1.3780	35 1.3780	16 0.6299	18 0.709	0.85 0.033	52.3 2.059	17 0.669	0.6 0.024	GCU 35 MM	GCUL 35 MM
40 1.5748	40 1.5748	18 0.7087	20 0.787	0.85 0.033	58.3 2.295	19 0.748	1.0 0.039	GCU 40 MM	GCUL 40 MM
47 1.8504	47 1.8504	20 0.7874	24 0.945	0.85 0.033	66.3 2.610	21 0.827	1.0 0.039	GCU 47 MM	GCUL 47 MM
52 2.0472	52 2.0472	20 0.7874	24 0.945	0.85 0.033	66.3 2.610	21 0.827	1.0 0.039	GCU 52 MM	GCUL 52 MM
62 2.4409	62 2.4409	24 0.9449	29 1.142	0.85 0.033	80.3 3.161	25 0.984	1.0 0.039	GCU 62 MM	GCUL 62 MM
72 2.8346	72 2.8346	24 0.9449	29 1.142	0.85 0.033	80.3 3.161	25 0.984	1.1 0.043	GCU 72 MM	GCUL 72 MM
80 3.1496	80 3.1496	30 1.1811	35 1.378	1.10 0.043	100.3 3.949	32 1.260	1.1 0.043	GCU 80 MM	GCUL 80 MM
90 3.5433	90 3.5433	30 1.1811	35 1.378	1.10 0.043	100.3 3.949	32 1.260	1.1 0.043	GCU 90 MM	GCUL 90 MM
100 3.9370	100 3.9370	36 1.4173	40 1.575	1.10 0.043	117.3 4.618	38 1.496	2.0 0.079	GCU 100 MM	GCUL 100 MM
110 4.3307	110 4.3307	36 1.4173	40 1.575	1.10 0.043	117.3 4.618	38 1.496	2.0 0.079	GCU 110 MM	GCUL 110 MM
120 4.7244	120 4.7244	42 1.6535	46 1.811	1.10 0.043	136.3 5.366	44 1.732	2.0 0.079	GCU 120 MM	GCUL 120 MM
130 5.1181	130 5.1181	42 1.6535	46 1.811	1.10 0.043	136.3 5.366	44 1.732	2.0 0.079	GCU 130 MM	GCUL 130 MM

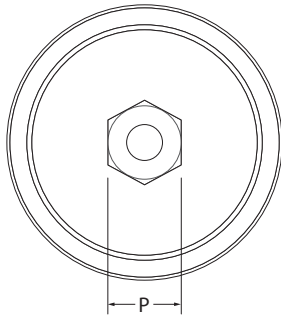

Hex Socket Roller End

Tightening Torque	Load Ratings					Speed Rating Grease	P		B ₂	B ₃	d ₄	M	Wt.
	As a Bearing		As a Track Roller				Wrench						
	C	C ₀	C _w	F _{r perm}	F _{0r perm}								
N-m lb-in.	kN lbf.		kN lbf.			min ⁻¹	mm	mm in.	mm in.	mm in.	mm in.	kg lbs.	
64 566	26.4 5930	32.4 7280	15.4 3460	7.25 1630	13.1 2940	2200	10	32.8 1.291	8 0.315	6 0.236	26.0 1.024	0.200 0.441	
90 797	26.4 5930	32.4 7280	18.7 4200	12.1 2720	21.8 4900	2200	12	36.8 1.449	8 0.315	6 0.236	28.6 1.126	0.289 0.637	
120 1060	43.8 9850	57.9 13000	26.7 6000	14.3 3210	25.8 5800	1600	14	40.8 1.606	9 0.354	6 0.236	33.6 1.323	0.450 0.992	
120 1060	43.8 9850	57.9 13000	30.6 6880	21.2 4770	38.2 8590	1600	14	40.8 1.606	9 0.354	6 0.236	33.6 1.323	0.520 1.146	
220 1950	63.7 14300	87.4 19600	44.1 9910	30.9 6950	55.6 12500	1400	12	49.8 1.961	11 0.433	6 0.236	38.9 1.531	0.910 2.006	
220 1950	63.7 14300	87.4 19600	50.8 11400	52.7 11800	84.1 18900	1400	12	49.8 1.961	11 0.433	6 0.236	38.9 1.531	1.140 2.513	
450 3980	100 22500	140 31500	66.8 15000	43.8 9850	78.8 17700	1000	14	63.3 2.492	15 0.591	8 0.315	51.8 2.039	1.870 4.123	
450 3980	100 22500	140 31500	75.8 17000	68.1 15300	122 27400	1000	14	63.3 2.492	15 0.591	8 0.315	51.8 2.039	2.230 4.914	
740 6550	115 25900	175 39300	82.1 18500	76.6 17200	135 30300	840	17	75.3 2.965	20 0.787	8 0.315	61.0 2.402	3.290 7.253	
740 6550	115 25900	175 39300	89.7 20200	107 24100	161 36200	840	17	75.3 2.965	20 0.787	8 0.315	61.0 2.402	3.800 8.378	
1 200 10620	167 37500	240 54000	124 27900	107 24100	193 43400	740	19	88.3 3.476	24 0.945	8 0.315	71.0 2.795	5.422 11.953	
1 200 10620	167 37500	240 54000	133 30000	142 31900	228 51300	740	19	88.3 3.476	24 0.945	8 0.315	71.0 2.795	5.780 12.743	





NEEDLE ROLLER BEARINGS

FULL COMPLEMENT, ECCENTRIC, STUD-TYPE (GCR SERIES) METRIC SERIES

B

GCR: crowned outer ring
GCRL: cylindrical outer ring

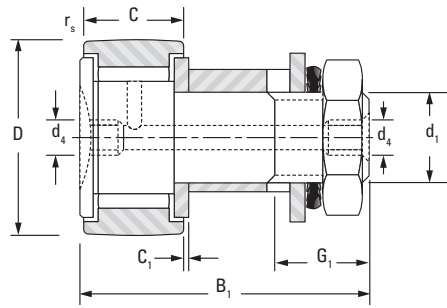

GCR 16-52

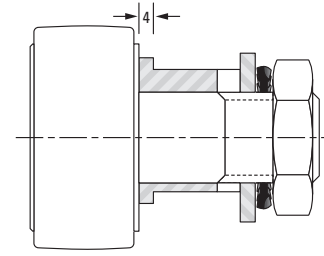

GCR 62-90

Outer Dia.	D	d ₁	C	C ₁	B ₁	G ₁	r _s min	Crowned Designation	Cylindrical Designation
mm in.	mm in.	mm in.	mm in.	mm in.	mm in.	mm in.	mm in.		
16 0.6299	16 0.6299	6 0.2362	11 0.433	0.60 0.024	28.3 1.114	8 0.315	0.3 0.012	GCR 16	
19 0.748	19 0.748	8 0.315	11 0.433	0.60 0.024	32.3 1.272	10 0.394	0.3 0.012	GCR 19	
22 0.8661	22 0.8661	10 0.3937	12 0.472	0.60 0.024	36.3 1.429	12 0.472	0.3 0.012	GCR 22	GCRL 22
24 0.9449	24 0.9449	10 0.3937	12 0.472	0.60 0.024	36.3 1.429	12 0.472	0.3 0.012	GCR 24	
26 1.0236	26 1.0236	10 0.3937	12 0.472	0.60 0.024	36.3 1.429	12 0.472	0.3 0.012	GCR 26	GCRL 26
28 1.1024	28 1.1024	10 0.3937	12 0.472	0.60 0.024	36.3 1.429	12 0.472	0.3 0.012	GCR 28	GCRL 28
30 1.1811	30 1.1811	12 0.4724	14 0.551	0.60 0.024	40.3 1.587	13 0.512	0.6 0.024	GCR 30	GCRL 30
32 1.2598	32 1.2598	12 0.4724	14 0.551	0.60 0.024	40.3 1.587	13 0.512	0.6 0.024	GCR 32	GCRL 32
35 1.378	35 1.378	16 0.6299	18 0.709	0.80 0.031	52.3 2.059	17 0.669	0.6 0.024	GCR 35	GCRL 35
40 1.5748	40 1.5748	18 0.7087	20 0.787	0.80 0.031	58.3 2.295	19 0.748	1 0.039	GCR 40	GCRL 40
47 1.8504	47 1.8504	20 0.7874	24 0.945	0.80 0.031	66.3 2.61	21 0.827	1 0.039	GCR 47 EE	GCRL 47
52 2.0472	52 2.0472	20 0.7874	24 0.945	0.80 0.031	66.3 2.61	21 0.827	1 0.039	GCR 52	GCRL 52
62 2.4409	62 2.4409	24 0.9449	29 1.142	0.80 0.031	80.3 3.161	25 0.984	1 0.039	GCR 62	GCRL 62
72 2.8346	72 2.8346	24 0.9449	29 1.142	0.80 0.031	80.3 3.161	25 0.984	1 0.039	GCR 72	GCRL 72
80 3.1496	80 3.1496	30 1.1811	35 1.378	1.00 0.039	100.3 3.949	32 1.26	1 0.039	GCR 80	
90 3.5433	90 3.5433	30 1.1811	35 1.378	1.00 0.039	100.3 3.949	32 1.26	1 0.039	GCR 90	GCRL 90

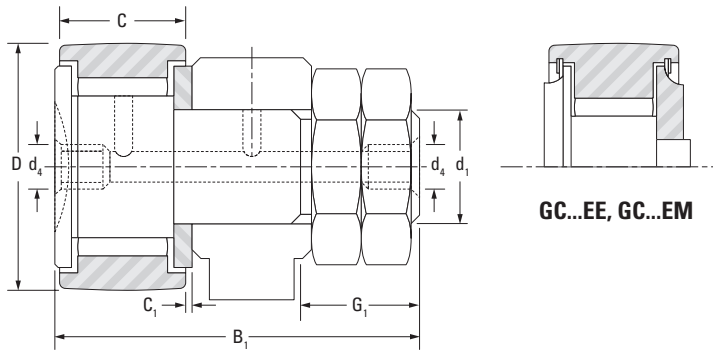

GCR..EE, GCR..EEM
GCRL..EE, GCRL..EEM



Tightening Torque	Load Ratings					Speed Rating Grease	d ₄	Wt.
	As a Bearing		As a Track Roller					
	C	C ₀	C _w	F _{r perm}	F _{0r perm}			
N·m lb-in.	kN lbf.		kN lbf.			min ⁻¹	mm in.	kg lbs.
2 17.7	5.66 1270	6.51 1460	4.19 942	2.79 627	5.02 1130	5700	4 0.157	0.024 0.053
5 44.3	6.44 1450	8.15 1830	4.65 1050	3 785	6.28 1410	4400	4 0.157	0.039 0.086
16 142	7.3 1640	10.2 2290	5.05 1140	4.07 915	7.33 1650	3500	4 0.157	0.057 0.126
16 142	7.3 1640	10.2 2290	5.45 1230	5.42 1220	8.63 1940	3500	4 0.157	0.072 0.159
16 142	9.92 2230	12.9 2900	7.09 1590	5.43 1220	9.77 2200	3200	4 0.157	0.080 0.176
16 142	9.92 2230	12.9 2900	7.57 1700	6.95 1560	11.4 2560	3200	4 0.157	0.088 0.194
22 195	15.5 3480	20.4 4590	11.2 2520	8.48 1910	15.3 3440	2900	4 0.157	0.118 0.260
22 195	15.5 3480	20.4 4590	11.8 2650	10.6 2380	18.1 4070	2900	4 0.157	0.126 0.278
55 487	23.6 5310	33.1 7440	15.7 3530	10.8 2430	19.4 4360	2200	6 0.236	0.220 0.485
75 664	29.9 6720	48 10800	18.5 4160	13.8 3100	24.8 5580	1800	6 0.236	0.321 0.708
100 885	36.5 8210	65.5 14700	22.5 5060	20.2 4540	36.4 8180	1400	6 0.236	0.500 1.102
100 885	36.5 8210	65.5 14700	25.2 5670	28 6290	47.5 10700	1400	6 0.236	0.568 1.252
180 1590	43.3 9730	85.6 19200	30.5 6860	42.9 9640	64.7 14500	1200	8 0.315	1.035 2.282
180 1590	43.3 9730	85.6 19200	33.9 7620	65.8 14800	79.5 17900	1200	8 0.315	1.278 2.818
370 3270	65.1 14600	144 32400	42.7 9600	62.9 14100	95.3 21400	870	8 0.315	2.074 4.572
370 3270	65.1 14600	144 32400	47.1 10600	88.8 20000	115 25900	870	8 0.315	2.435 5.368





NEEDLE ROLLER BEARINGS

FULL COMPLEMENT, ECCENTRIC, WITH METAL SEALS, STUD-TYPE (GCUR...MM SERIES) METRIC SERIES

GCUR: crowned outer ring
GCURL: cylindrical outer ring

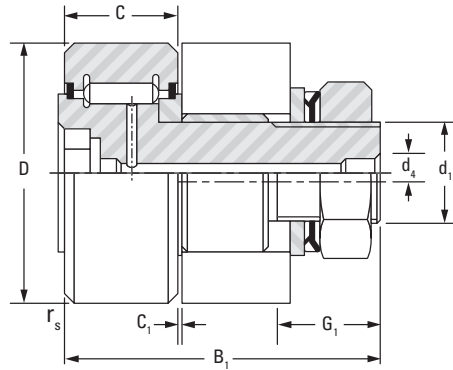

GCUR 35-52

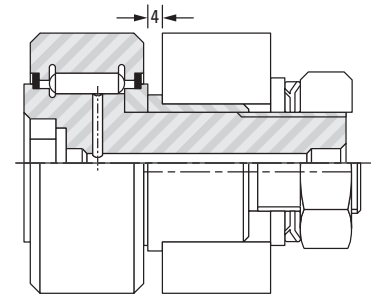

GCUR 62-130

Outer Dia.	D	d ₁	C	C ₁	B ₁	G ₁	r _s min	Crowned Designation	Cylindrical Designation
mm in.	mm in.	mm in.	mm in.	mm in.	mm in.	mm in.	mm in.		
35 1.3780	35 1.3780	16 0.6299	18 0.709	0.85 0.033	52.3 2.059	17 0.669	0.6 0.024	GCUR 35 MM	
40 1.5748	40 1.5748	18 0.7087	20 0.787	0.85 0.033	58.3 2.295	19 0.748	1.0 0.039		GCURL 40 MM
52 2.0472	52 2.0472	20 0.7874	24 0.945	0.85 0.033	66.3 2.610	21 0.827	1.0 0.039	GCUR 52 MM	
62 2.4409	62 2.4409	24 0.9449	29 1.142	0.85 0.033	80.3 3.161	25 0.984	1.0 0.039	GCUR 62 MM	
72 2.8346	72 2.8346	24 0.9449	29 1.142	0.85 0.033	80.3 3.161	25 0.984	1.1 0.043	GCUR 72 MM	
80 3.1496	80 3.1496	30 1.1811	35 1.378	1.10 0.043	100.3 3.949	32 1.260	1.1 0.043	GCUR 80 MM	
90 3.5433	90 3.5433	30 1.1811	35 1.378	1.10 0.043	100.3 3.949	32 1.260	1.1 0.043	GCUR 90 MM	
100 3.9370	100 3.9370	36 1.4173	40 1.575	1.10 0.043	117.3 4.618	38 1.496	2.0 0.079	GCUR 100 MM	
110 4.3307	110 4.3307	36 1.4173	40 1.575	1.10 0.043	117.3 4.618	38 1.496	2.0 0.079	GCUR 110 MM	
120 4.7244	120 4.7244	42 1.6535	46 1.811	1.10 0.043	136.3 5.366	44 1.732	2.0 0.079	GCUR 120 MM	
130 5.1181	130 5.1181	42 1.6535	46 1.811	1.10 0.043	136.3 5.366	44 1.732	2.0 0.079	GCUR 130 MM	

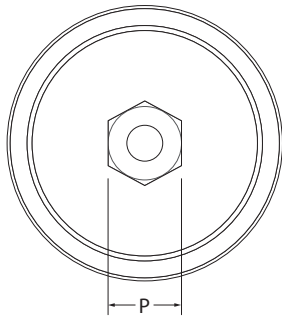

Hex Socket Roller End

Tightening Torque	Load Ratings					Speed Rating Grease	P		d ₄	Wt.
	As a Bearing		As a Track Roller				Wrench	mm		
	C	C ₀	C _w	F _{r perm}	F _{Dr perm}					
N-m lb-in.	kN lbf.		kN lbf.			min ⁻¹	mm	mm in.	kg lbs.	
55 487	26.4 5930	32.4 7280	15.4 3460	7.25 1630	13.1 2940	2200	10	6 0.236	0.215 0.474	
75 664	26.4 5930	32.4 7280	18.7 4200	12.1 2720	21.8 4900	2200	12	6 0.236	0.313 0.690	
100 885	43.8 9850	57.9 13000	30.6 6880	21.2 4770	38.2 8590	1600	14	6 0.236	0.555 1.224	
180 1593	63.7 14300	87.4 19600	44.1 9910	30.9 6950	55.6 12500	1400	12	6 0.236	1.022 2.253	
180 1593	63.7 14300	87.4 19600	50.8 11400	52.7 11800	84.1 18900	1400	12	6 0.236	0.113 0.249	
370 3275	100 22500	140 31500	66.8 15000	43.8 9850	78.8 17700	1000	14	8 0.315	0.182 0.401	
370 3275	100 22500	140 31500	75.8 17000	68.1 15300	122 27400	1000	14	8 0.315	0.182 0.401	
610 5399	115 25900	175 39300	82.1 18500	76.6 17200	135 30300	840	17	8 0.315	0.244 0.539	
610 5399	115 25900	175 39300	89.7 20200	107 24100	161 36200	840	17	8 0.315	0.245 0.540	
1000 8851	167 37500	240 54000	124 27900	107 24100	193 43400	740	19	8 0.315	0.328 0.724	
1000 8851	167 37500	240 54000	133 30000	142 31900	228 51300	740	19	8 0.315	0.329 0.725	





NEEDLE ROLLER BEARINGS

**CAGED, WITHOUT INNER RING,
NO END WASHERS,
YOKE-TYPE (RSTO SERIES)
METRIC SERIES**

B

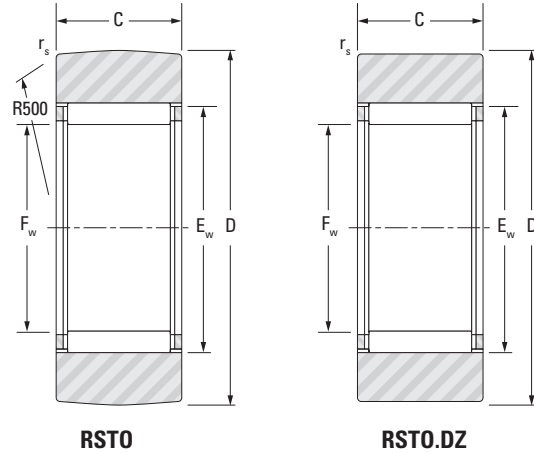

Outer Dia.	D	C	F _w	E _w	r _{s min}	Bearing Designation	Load Ratings					Speed Rating Grease	Wt.
							As a Bearing		As a Track Roller				
							Dynamic	Static	Dynamic		Static		
							C	C ₀	C _w	F _{r perm}	F _{0r perm}		
mm in.	mm in.	mm in.	mm in.	mm in.	mm in.	kN lbf.		kN lbf.		min ⁻¹	kg lbs.		
16 0.6299	16 0.6299	7.8 0.307	7 0.2756	10 0.394	0.3 0.012	RST05A.TN RST05ADZ.TN	2.74 616	2.44 549	2.49 560	2.97 668	2.44 549	19000	0.009 0.020
19 0.7480	19 0.7480	9.8 0.386	10 0.3937	13 0.512	0.3 0.012	RST06 RST06DZ	5.40 1210	6.43 1450	4.15 933	4.04 908	5.63 1270	13000	0.014 0.031
24 0.9449	24 0.9449	9.8 0.386	12 0.4724	15 0.591	0.3 0.012	RST08 RST08DZ	5.85 1320	7.51 1690	4.79 1080	6.67 1500	7.44 1670	10000	0.023 0.051
30 1.1811	30 1.1811	11.8 0.465	14 0.5512	20 0.787	0.3 0.012	RST010 RST010DZ	10.40 2340	10.6 2380	8.62 1940	7.69 1730	10.6 2380	9400	0.044 0.097
32 1.2598	32 1.2598	11.8 0.465	16 0.6299	22 0.866	0.3 0.012	RST012 RST012DZ	11.20 2520	11.9 2680	8.80 1980	7.65 1720	10.9 2450	8100	0.049 0.108
35 1.3780	35 1.3780	11.8 0.465	20 0.7874	26 1.024	0.3 0.012	RST015 RST015DZ	12.90 2900	15.3 3440	9.13 2050	6.95 1560	11.2 2520	6300	0.052 0.115
40 1.5748	40 1.5748	15.8 0.622	22 0.8661	29 1.142	0.3 0.012	RST017 RST017DZ	19.00 4270	23.3 5240	13.8 3100	11.4 2560	18.2 4090	5800	0.095 0.209
47 1.8504	47 1.8504	15.8 0.622	25 0.9843	32 1.260	0.3 0.012	RST020 RST020DZ	20.00 4500	25.3 5690	15.3 3440	16.5 3710	22.2 4990	5000	0.134 0.295
52 2.0472	52 2.0472	15.8 0.622	30 1.1811	37 1.457	0.3 0.012	RST025 RST025DZ	22.40 5040	31.0 6970	16.0 3600	16.9 3800	23.7 5330	4100	0.155 0.342
62 2.4409	62 2.4409	19.8 0.780	38 1.4961	46 1.811	0.6 0.024	RST030 RST030DZ	33.30 7490	51.0 11470	22.3 5010	23.2 5220	34.2 7690	3200	0.258 0.569
72 2.8346	72 2.8346	19.8 0.780	42 1.6535	50 1.969	0.6 0.024	RST035 RST035DZ	35.20 7910	56.6 12720	25.2 5670	33.3 7490	43.0 9670	2900	0.37 0.816
80 3.1496	80 3.1496	19.8 0.780	50 1.9685	58 2.283	0.6 0.024	RST040 RST040DZ	38.80 8720	67.8 15240	25.9 5820	34.7 7800	45.0 10120	2400	0.430 0.948
85 3.3465	85 3.3465	19.8 0.780	55 2.1654	63 2.480	0.6 0.024	RST045	40.30 9060	73.5 16520	26.0 5850	35.8 8050	45.5 10230	2200	0.447 0.985
90 3.5433	90 3.5433	19.8 0.780	60 2.3622	68 2.677	0.6 0.024	RST050	41.80 9400	79.2 17800	26.0 5850	37.1 8340	45.8 10300	2000	0.495 1.091

**CAGED, WITH INNER RING,
NO END WASHERS
YOKE-TYPE (STO SERIES)
METRIC SERIES**

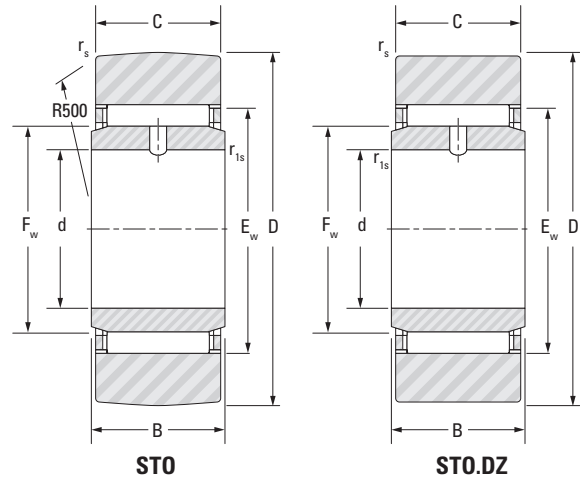

Outer Dia.	D	d	B	C	F _w	E _w	r _s	r _{1s} min	Bearing Designation	Load Ratings					Speed Rating Grease	Wt.
										As a Bearing		As a Track Roller				
										Dynamic	Static	Dynamic		Static		
										C	C ₀	C _w	F _r perm	F _{0r} perm		
mm in.	mm in.	mm in.	mm in.	mm in.	mm in.	mm in.	mm in.	mm in.		kN lbf.	kN lbf.	min ⁻¹	kg lbs.			
19 0.7480	19 0.7480	6 0.2362	10 0.394	9.8 0.386	10 0.3937	13 0.5118	0.3 0.012	0.3 0.012	ST06 ST06DZ	5.40 1210	6.43 1450	4.15 933	4.04 908	5.63 1270	9400	0.018 0.040
24 0.9449	24 0.9449	8 0.3150	10 0.394	9.8 0.386	12 0.4724	15 0.5906	0.3 0.012	0.3 0.012	ST08 ST08DZ	5.85 1320	7.51 1690	4.79 1080	6.67 1500	7.44 1670	8100	0.028 0.062
30 1.1811	30 1.1811	10 0.3937	12 0.472	11.8 0.465	14 0.5512	20 0.7874	0.3 0.012	0.3 0.012	ST010 ST010DZ	10.4 2340	10.6 2380	8.62 1940	7.69 1730	10.6 2380	6300	0.065 0.143
32 1.2598	32 1.2598	12 0.4724	12 0.472	11.8 0.465	16 0.6299	22 0.8661	0.3 0.012	0.3 0.012	ST012 ST012DZ	11.2 2520	11.9 2680	8.80 1980	7.65 1720	10.9 2450	5800	0.114 0.251
35 1.3780	35 1.3780	15 0.5906	12 0.472	11.8 0.465	20 0.7874	26 1.0236	0.3 0.012	0.3 0.012	ST015 ST015DZ	12.9 2900	15.3 3440	9.13 2050	6.95 1560	11.2 2520	5000	0.160 0.353
40 1.5748	40 1.5748	17 0.6693	16 0.630	15.8 0.622	22 0.8661	29 1.1417	0.3 0.012	0.3 0.012	ST017 ST017DZ	19.1 4290	23.3 5240	13.8 3100	11.4 2560	18.2 4090	4100	0.114 0.251
47 1.8504	47 1.8504	20 0.7874	16 0.630	15.8 0.622	25 0.9843	32 1.2598	0.3 0.012	0.3 0.012	ST020 ST020DZ	19.8 4450	25.3 5690	15.3 3440	16.5 3710	22.2 4990	3200	0.325 0.717
52 2.0472	52 2.0472	25 0.9843	16 0.630	15.8 0.622	30 1.1811	37 1.4567	0.3 0.012	0.3 0.012	ST025 ST025DZ	22.4 5040	31.0 6970	16.0 3600	16.9 3800	23.7 5330	2900	0.435 0.959
62 2.4409	62 2.4409	30 1.1811	20 0.787	19.8 0.780	38 1.4961	46 1.8110	0.6 0.024	0.6 0.024	ST030 ST030DZ	33.3 7490	51.0 11470	22.3 5010	23.2 5220	34.2 7690	2400	0.325 0.717
72 2.8346	72 2.8346	35 1.3780	20 0.787	19.8 0.780	42 1.6535	50 1.9685	0.6 0.024	0.6 0.024	ST035 ST035DZ	35.2 7910	56.6 12720	25.2 5670	33.3 7490	43.0 9670	2200	0.435 0.959
80 3.1496	80 3.1496	40 1.5748	20 0.787	19.8 0.780	50 1.9685	58 2.2835	0.6 0.024	1.0 0.039	ST040 ST040DZ	38.8 8720	67.8 15240	25.9 5820	34.7 7800	45.0 10120	2400	0.540 1.190
85 3.3465	85 3.3465	45 1.7717	20 0.787	19.8 0.780	55 2.1654	63 2.4803	0.6 0.024	1.0 0.039	ST045 ST045DZ	40.3 9060	73.5 16520	26.0 5850	35.8 8050	45.5 10230	2200	0.580 1.279
90 3.5433	90 3.5433	50 1.9685	20 0.787	19.8 0.780	60 2.3622	68 2.6772	0.6 0.024	1.0 0.039	ST050 ST050DZ	41.8 9400	79.2 17800	26.0 5850	37.1 8340	45.8 10300	2000	0.650 1.433





NEEDLE ROLLER BEARINGS

**CAGED, WITHOUT INNER RING,
NO END WASHERS, SEALED,
YOKE-TYPE (RNA22 SERIES)
METRIC SERIES**

B

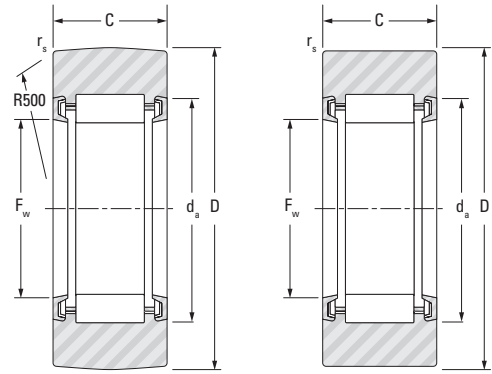

RNA22.2RS

RNA22.2RS.DZ

Outer Dia.	D	C	F _w	d _a	r _s min	Bearing Designation	Load Ratings					Speed Rating Grease	Wt.
							As a Bearing		As a Track Roller				
							Dynamic	Static	Dynamic		Static		
							C	C ₀	C _w	F _{r perm}	F _{0r perm}		
mm in.	mm in.	mm in.	mm in.	mm in.	mm in.	kN lbf.	kN lbf.	min ⁻¹	kg lbs.				
19 0.7480	19 0.7480	11.8 0.465	10 0.3937	14 0.551	0.3 0.012	RNA22/6.2RS RNA22/6.2RS.DZ	4.70 1060	5.43 1220	4.13 928	3.06 688	4.59 1030	13000	0.014 0.031
24 0.9449	24 0.9449	11.8 0.465	12 0.4724	18 0.709	0.3 0.012	RNA22/8.2RS RNA22/8.2RS.DZ	6.70 1510	6.08 1370	5.31 1190	3.37 758	5.22 1170	11000	0.025 0.055
30 1.1811	30 1.1811	13.8 0.543	14 0.5512	20 0.787	0.6 0.024	RNA2200.2RS RNA2200.2RS.DZ	8.50 1910	9.45 2120	8.03 1810	7.85 1760	9.45 2120	9400	0.049 0.108
32 1.2598	32 1.2598	13.8 0.543	16 0.6299	22 0.866	0.6 0.024	RNA2201.2RS RNA2201.2RS.DZ	9.00 2020	10.5 2360	8.2 1840	7.78 1750	10.1 2270	8100	0.053 0.117
35 1.3780	35 1.3780	13.8 0.543	20 0.7874	27 1.063	0.6 0.024	RNA2202.2RS RNA2202.2RS.DZ	12.2 2740	14.5 3260	9.24 2080	6.00 1350	10.2 2290	6300	0.055 0.121
40 1.5748	40 1.5748	15.8 0.622	22 0.8661	30 1.181	1.0 0.039	RNA2203.2RS RNA2203.2RS.DZ	16.3 3660	17.8 4000	11.9 2680	8.50 1910	13.7 3080	5900	0.090 0.198
47 1.8504	47 1.8504	17.8 0.701	25 0.9843	35 1.378	1.0 0.039	RNA2204.2RS RNA2204.2RS.DZ	19.6 4410	20.2 4540	14.8 3330	11.0 2470	16.7 3750	5200	0.150 0.331
52 2.0472	52 2.0472	17.8 0.701	30 1.1811	40 1.575	1.0 0.039	RNA2205.2RS RNA2205.2RS.DZ	21.6 4860	24.3 5460	15.5 3480	11.3 2540	17.7 3980	4300	0.171 0.377
62 2.4409	62 2.4409	19.8 0.780	35 1.3780	47 1.850	1.0 0.039	RNA2206.2RS RNA2206.2RS.DZ	29.0 6520	32.8 7370	21.2 4770	15.8 3550	24.8 5580	3700	0.285 0.628
72 2.8346	72 2.8346	22.8 0.898	42 1.6535	54 2.126	1.1 0.043	RNA2207.2RS RNA2207.2RS.DZ	40.5 9100	52.5 11800	28.6 6430	24.2 5440	37.9 8520	3000	0.490 1.080
80 3.1496	80 3.1496	22.8 0.898	48 1.8898	60 2.362	1.1 0.043	RNA2208.2RS RNA2208.2RS.DZ	44.0 9890	60.0 13490	30.4 6830	27.8 6250	42.0 9440	2600	0.515 1.135
85 3.3465	85 3.3465	22.8 0.898	52 2.0472	64 2.520	1.1 0.043	RNA2209.2RS RNA2209.2RS.DZ	45.6 10250	63.9 14370	30.9 6950	29.7 6680	43.7 9820	2400	0.565 1.246
90 3.5433	90 3.5433	22.8 0.898	58 2.2835	70 2.756	1.1 0.043	RNA2210.2RS RNA2210.2RS.DZ	48.5 10900	71.3 16030	31.0 6970	29.4 6610	43.4 9760	2100	0.590 1.301

**CAGED, WITH INNER RING,
NO END WASHERS, SEALED,
YOKE-TYPE (NA22 SERIES)
METRIC SERIES**

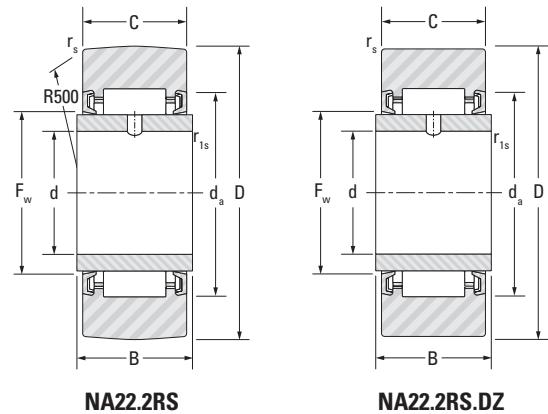

Outer Dia.	D	d	B	C	F _w	d _a	r _s	r _{1s min}	Bearing Designation		Load Ratings					Speed Rating Grease	Wt.
											As a Bearing		As a Track Roller				
											Dynamic	Static	Dynamic	Static			
											C	C ₀	C _w	F _{r perm}	F _{0r perm}		
mm in.	mm in.	mm in.	mm in.	mm in.	mm in.	mm in.	mm in.	mm in.	kN lbf.	kN lbf.	kN lbf.	kN lbf.	min ⁻¹	kg lbs.			
19 0.7480	19 0.7480	6 0.2362	12 0.472	11.8 0.465	10 0.3937	14 0.5512	0.3 0.012	0.3 0.012	NA22/6.2RS	NA22/6.2RS.DZ	4.70 1060	5.43 1220	4.13 928	3.06 688	4.59 1030	13000	0.018 0.040
24 0.9449	24 0.9449	8 0.3150	12 0.472	11.8 0.465	12 0.4724	18 0.7087	0.3 0.012	0.3 0.012	NA22/8.2RS	NA22/8.2RS.DZ	6.70 1510	6.08 1370	5.31 1190	3.37 758	5.22 1170	11000	0.031 0.068
30 1.1811	30 1.1811	10 0.3937	14 0.551	13.8 0.543	14 0.5512	20 0.7874	0.6 0.024	0.3 0.012	NA2200.2RS	NA2200.2RS.DZ	8.50 1910	9.45 2120	8.03 1810	7.85 1760	9.45 2120	9400	0.057 0.126
32 1.2598	32 1.2598	12 0.4724	14 0.551	13.8 0.543	16 0.6299	22 0.8661	0.6 0.024	0.3 0.012	NA2201.2RS	NA2201.2RS.DZ	9.00 2020	10.5 2360	8.20 1840	7.78 1750	10.1 2270	8100	0.063 0.139
35 1.3780	35 1.3780	15 0.5906	14 0.551	13.8 0.543	20 0.7874	27 1.0630	0.6 0.024	0.3 0.012	NA2202.2RS	NA2202.2RS.DZ	12.2 2740	14.5 3260	9.24 2080	6.00 1350	10.2 2290	6300	0.070 0.154
40 1.5748	40 1.5748	17 0.6693	16 0.630	15.8 0.622	22 0.8661	30 1.1811	1.0 0.039	0.3 0.012	NA2203.2RS	NA2203.2RS.DZ	16.3 3660	17.8 4000	11.9 2680	8.50 1910	13.7 3080	5900	0.107 0.236
47 1.8504	47 1.8504	20 0.7874	18 0.709	17.8 0.701	25 0.9843	35 1.3780	1.0 0.039	0.3 0.012	NA2204.2RS	NA2204.2RS.DZ	19.6 4410	20.2 4540	14.8 3330	11.0 2470	16.7 3750	5200	0.175 0.386
52 2.0472	52 2.0472	25 0.9843	18 0.709	17.8 0.701	30 1.1811	40 1.5748	1.0 0.039	0.3 0.012	NA2205.2RS	NA2205.2RS.DZ	21.6 4860	24.3 5460	15.5 3480	11.3 2540	17.7 3980	4300	0.202 0.445
62 2.4409	62 2.4409	30 1.1811	20 0.787	19.8 0.780	35 1.3780	47 1.8504	1.0 0.039	0.3 0.012	NA2206.2RS	NA2206.2RS.DZ	29.0 6520	32.8 7370	21.2 4770	15.8 3550	24.8 5580	3700	0.324 0.714
72 2.8346	72 2.8346	35 1.3780	23 0.906	22.8 0.898	42 1.6535	54 2.1260	1.1 0.043	0.6 0.024	NA2207.2RS	NA2207.2RS.DZ	40.5 9100	52.5 11800	28.6 6430	24.2 5440	37.9 8520	3000	0.490 1.080
80 3.1496	80 3.1496	40 1.5748	23 0.906	22.8 0.898	48 1.8898	60 2.3622	1.1 0.043	0.6 0.024	NA2208.2RS	NA2208.2RS.DZ	44.0 9890	60.0 13500	30.4 6830	27.8 6250	42.0 9440	2600	0.615 1.356
85 3.3465	85 3.3465	45 1.7717	23 0.906	22.8 0.898	52 2.0472	64 2.5197	1.1 0.043	0.6 0.024	NA2209.2RS	NA2209.2RS.DZ	45.0 10100	63.9 14400	30.9 6950	29.7 6680	43.7 9820	2400	0.661 1.457
90 3.5433	90 3.5433	50 1.9685	23 0.906	22.8 0.898	58 2.2835	70 2.7559	1.1 0.043	0.6 0.024	NA2210.2RS	NA2210.2RS.DZ	48.0 10800	71.3 16000	31.0 6970	29.4 6610	43.4 9760	2100	0.712 1.570





NEEDLE ROLLER BEARINGS

CAGED, WITH INNER RING, WITH END WASHERS, YOKE-TYPE (NATR, STO...ZZ SERIES) METRIC SERIES

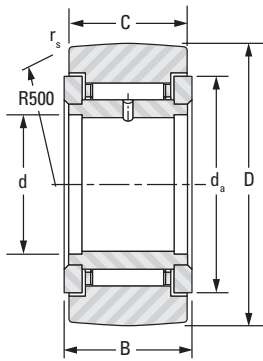

NATR

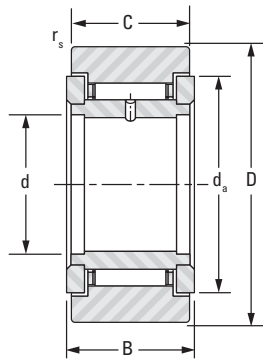

NATR.DZ

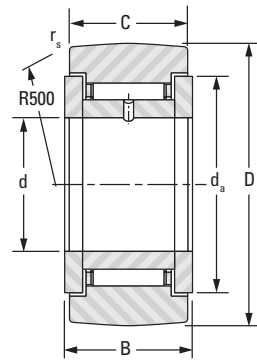

STO.ZZ

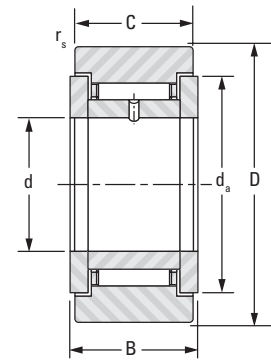

STO.ZZ.DZ

Outer Dia.	D	d	B	C	d _a	r _{s min}	Bearing Designation		Load Ratings					Speed Rating Grease	Wt.
									As a Bearing		As a Track Roller				
									Dynamic	Static	Dynamic		Static		
									C	C ₀	C _w	F _{r perm}	F _{0r perm}		
mm in.	mm in.	mm in.	mm in.	mm in.	mm in.	mm in.						min ⁻¹	kg lbs.		
16 0.6299	16 0.6299	5 0.1969	12 0.472	11.0 0.433	13 0.512	0.3 0.012	NATR5	NATR5DZ	4.62 1040	5.19 1170	3.34 751	2.62 589	4.01 901	13000	0.017 0.037
19 0.7480	19 0.7480	6 0.2362	12 0.472	11.0 0.433	16 0.630	0.3 0.012	NATR6	NATR6DZ	4.84 1090	5.66 1270	3.84 863	4.28 962	5.28 1190	12000	0.022 0.049
19 0.7480	19 0.7480	6 0.2362	14 0.551	13.8 0.543	15 0.591	0.3 0.012	STO6ZZ	STO6ZZ.DZ	5.37 1210	6.47 1450	4.31 969	5.23 1180	6.17 1390	12000	0.024 0.053
24 0.9449	24 0.9449	8 0.3150	14 0.551	13.8 0.543	18 0.709	0.3 0.012	STO8ZZ	STO8ZZ.DZ	5.82 1310	7.54 1700	4.97 1120	7.54 1700	8.14 1830	9900	0.040 0.088
24 0.9449	24 0.9449	8 0.3150	15 0.591	14.0 0.551	20 0.787	0.3 0.012	NATR8	NATR8DZ	8.39 1890	8.67 1950	6.66 1500	5.79 1300	8.08 1820	10000	0.043 0.095
30 1.1811	30 1.1811	10 0.3937	15 0.591	14.0 0.551	24 0.945	0.6 0.024	NATR10	NATR10DZ	9.57 2150	9.45 2120	8.15 1830	8.58 1930	10.1 2270	9400	0.068 0.150
30 1.1811	30 1.1811	10 0.3937	16 0.630	15.8 0.622	23 0.906	0.3 0.012	STO10ZZ	STO10ZZ.DZ	10.4 2340	10.6 2380	8.94 2010	9.64 2170	11.4 2560	9400	0.071 0.157
32 1.2598	32 1.2598	12 0.4724	15 0.591	14.0 0.551	26 1.024	0.6 0.024	NATR12	NATR12DZ	10.2 2290	10.5 2360	8.32 1870	8.50 1910	10.4 2340	8100	0.075 0.165
32 1.2598	32 1.2598	12 0.4724	16 0.630	15.8 0.622	25 0.984	0.3 0.012	STO12ZZ	STO12ZZ.DZ	11.2 2520	11.9 2680	9.13 2050	9.54 2140	11.7 2630	8100	0.078 0.172
35 1.3780	35 1.3780	15 0.5906	16 0.630	15.8 0.622	30 1.181	0.3 0.012	STO15ZZ	STO15ZZ.DZ	12.9 2900	15.3 3440	9.47 2130	8.52 1920	12.1 2720	6300	0.089 0.196
40 1.5748	40 1.5748	17 0.6693	20 0.787	19.8 0.780	33 1.299	0.3 0.012	STO17ZZ	STO17ZZ.DZ	19.0 4270	23.3 5240	14.2 3190	13.4 3010	19.3 4340	5600	0.145 0.320
47 1.8504	47 1.8504	20 0.7874	20 0.787	19.8 0.780	37 1.457	0.3 0.012	STO20ZZ	STO20ZZ.DZ	20.0 4500	25.4 5710	15.7 3530	19.5 4380	23.5 5280	4900	0.200 0.441
52 2.0472	52 2.0472	25 0.9843	20 0.787	19.8 0.780	42 1.654	0.3 0.012	STO25ZZ	STO25ZZ.DZ	22.4 5040	31.1 6990	16.4 3690	19.8 4450	25.1 5640	4100	0.240 0.529
62 2.4409	62 2.4409	30 1.1811	25 0.984	24.8 0.976	52 2.047	0.6 0.024	STO30ZZ	STO30ZZ.DZ	33.3 7490	51.0 11500	23.0 5170	26.9 6050	36.2 8140	3200	0.412 0.908
72 2.8346	72 2.8346	35 1.3780	25 0.984	24.8 0.976	56 2.205	0.6 0.024	STO35ZZ	STO35ZZ.DZ	35.2 7910	56.6 12700	25.9 5820	39.2 8810	45.5 10200	2900	0.555 1.224
80 3.1496	80 3.1496	40 1.5748	26 1.024	25.8 1.016	64 2.520	0.6 0.024	STO40ZZ	STO40ZZ.DZ	38.8 8720	67.8 15200	26.8 6020	41.5 9330	48.1 10800	2400	0.700 1.543
85 3.3465	85 3.3465	45 1.7717	26 1.024	25.8 1.016	69 2.717	0.6 0.024	STO45ZZ	STO45ZZ.DZ	40.3 9060	73.5 16500	26.9 6050	42.4 9530	48.6 10900	2200	0.770 1.698

**FULL COMPLEMENT,
WITH INNER RING,
WITH END WASHERS,
CYLINDRICAL ROLLERS,
YOKE-TYPE (NUTR SERIES)
METRIC SERIES**

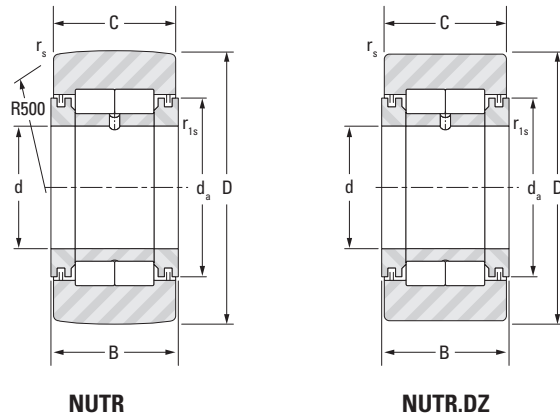

Outer Dia.	D	d	B	C	d _a	r _s	r _{1s} min	Bearing Designation		Load Ratings					Speed Rating Grease	Wt.
										As a Bearing		As a Track Roller				
										Dynamic	Static	Dynamic		Static		
										C	C ₀	C _w	F _{r perm}	F _{0r perm}		
mm in.	mm in.	mm in.	mm in.	mm in.	mm in.	mm in.	mm in.			kN lbf.	kN lbf.			min ⁻¹	kg lbs.	
35 1.3780	35 1.3780	15 0.5906	19 0.748	18 0.709	24 0.945	0.6 0.024	0.3 0.012	NUTR15	NUTR15DZ	24.7 5550	29.3 6590	16.2 3640	10.1 2270	16.1 3620	6100	0.105 0.231
40 1.5748	40 1.5748	17 0.6693	21 0.827	20 0.787	27 1.063	1.0 0.039	0.3 0.012	NUTR17	NUTR17DZ	26.6 5980	33.4 7510	18.7 4200	15.0 3370	23.9 5370	5300	0.154 0.340
42 1.6535	42 1.6535	15 0.5906	19 0.748	18 0.709	24 0.945	0.6 0.024	0.3 0.012	NUTR1542	NUTR1542DZ	22.8 5130	29.4 6610	20.0 4500	21.2 4770	28.4 6380	6100	0.166 0.366
47 1.8504	47 1.8504	17 0.6693	21 0.827	20 0.787	27 1.063	1.0 0.039	0.3 0.012	NUTR1747	NUTR1747DZ	24.5 5510	33.3 7490	22.0 4950	28.1 6320	33.6 7550	5300	0.230 0.507
	47 1.8504	20 0.7874	25 0.984	24 0.945	32 1.260	1.0 0.039	0.3 0.012	NUTR20	NUTR20DZ	39.0 8770	53.2 12000	28.1 6320	20.5 4610	32.7 7350	4500	0.254 0.560
52 2.0472	52 2.0472	20 0.7874	25 0.984	24 0.945	32 1.260	1.0 0.039	0.3 0.012	NUTR2052	NUTR2052DZ	39.0 8770	53.2 12000	31.6 7100	31.0 6970	45.9 10300	4500	0.326 0.719
	52 2.0472	25 0.9843	25 0.984	24 0.945	37 1.457	1.0 0.039	0.3 0.012	NUTR25	NUTR25DZ	43.0 9670	63.1 14200	29.6 6650	22.2 4990	35.4 7960	3700	0.291 0.642
62 2.4409	62 2.4409	25 0.9843	25 0.984	24 0.945	37 1.457	1.0 0.039	0.3 0.012	NUTR2562	NUTR2562DZ	43.0 9670	63.1 14200	36.0 8090	43.9 9870	57.8 13000	3700	0.460 1.014
	62 2.4409	30 1.1811	29 1.142	28 1.102	44 1.732	1.0 0.039	0.3 0.012	NUTR30	NUTR30DZ	60.0 13500	83.1 18700	40.8 9170	29.0 6520	46.2 10400	3200	0.480 1.058
72 2.8346	72 2.8346	30 1.1811	29 1.142	28 1.102	44 1.732	1.0 0.039	0.3 0.012	NUTR3072	NUTR3072DZ	60.0 13500	83.1 18700	48.6 10900	53.2 12000	74.2 16700	3200	0.711 1.567
	72 2.8346	35 1.3780	29 1.142	28 1.102	50 1.969	1.1 0.043	0.6 0.024	NUTR35	NUTR35DZ	65.5 14700	97.8 22000	45.9 10300	38.7 8700	61.7 13900	2600	0.655 1.444
80 3.1496	80 3.1496	35 1.3780	29 1.142	28 1.102	50 1.969	1.1 0.043	0.6 0.024	NUTR3580	NUTR3580DZ	65.5 14700	97.8 22000	51.7 11600	58.7 13200	81.9 18400	2600	0.865 1.907
	80 3.1496	40 1.5748	32 1.260	30 1.181	55 2.165	1.1 0.043	0.6 0.024	NUTR40	NUTR40DZ	88.0 19800	132 29700	60.6 13600	48.0 10800	76.5 17200	2500	0.848 1.870
85 3.3465	85 3.3465	45 1.7717	32 1.260	30 1.181	60 2.362	1.1 0.043	0.6 0.024	NUTR45	NUTR45DZ	93.0 20900	146 32800	62.0 13900	50.2 11300	80.0 18000	2200	0.917 2.022
90 3.5433	90 3.5433	40 1.5748	32 1.260	30 1.181	55 2.165	1.1 0.043	0.6 0.024	NUTR4090	NUTR4090DZ	88.0 19800	132 29700	69.1 15500	75.4 17000	111 25000	2500	1.162 2.562
	90 3.5433	50 1.9685	32 1.260	30 1.181	65 2.559	1.1 0.043	0.6 0.024	NUTR50	NUTR50DZ	98.0 22000	160 36000	63.3 14200	52.9 11900	84.3 19000	2000	0.988 2.178
100 3.9370	100 3.9370	45 1.7717	32 1.260	30 1.181	60 2.362	1.1 0.043	0.6 0.024	NUTR45100	NUTR45100DZ	93.0 20900	146 32800	74.3 16700	92.2 20700	127 28600	2200	1.412 3.113
110 4.3307	110 4.3307	50 1.9685	32 1.260	30 1.181	65 2.559	1.1 0.043	0.6 0.024	NUTR50110	NUTR50110DZ	98.0 22000	160 36000	79.0 17800	110 24700	141 31700	2000	1.727 3.807





NEEDLE ROLLER BEARINGS

FULL COMPLEMENT, NON-SEPARABLE, SMALL SERIES, UNSEALED, YOKE-TYPE (FP SERIES)

METRIC SERIES

FP: crowned outer ring
FPL: cylindrical outer ring

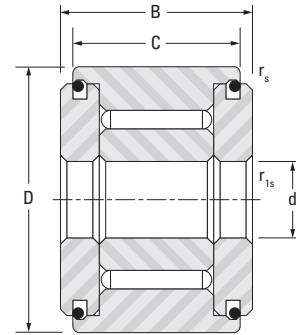

FP, FPL

Outer Dia.	D	d	C	B	r _s min	r _{1s} min	Designation		Load Ratings					Speed Rating Grease	Wt.
							Crowned Track Roller	Cylindrical Track Roller	As a Bearing		As a Track Roller				
									Dynamic	Static	Dynamic		Static		
									C	C ₀	C _w	F _{r perm}	F _{0r perm}		
mm in.	mm in.	mm in.	mm in.	mm in.	mm in.			kN lbf.		kN lbf.		min ⁻¹	kg lbs.		
10 0.3937	10 0.3937	3 0.1181	8 0.315	8.7 0.343	0.2 0.008	0.15 0.006	FP 3 10	FPL 3 10	2.8 629	3.09 695	2.12 432	1.43 227	2.58 409	8500	0.004 0.009
11 0.4331	11 0.4331	3 0.1181	8 0.315	8.7 0.343	0.2 0.008	0.15 0.006	FP 3 11	FPL 3 11	2.8 629	3.09 695	2.12 477	1.43 321	2.58 580	8500	0.005 0.011
12 0.4724	12 0.4724	4 0.1575	9 0.354	9.7 0.382	0.2 0.008	0.15 0.006	FP 4 12	FPL 4 12	3.74 841	4.74 1070	2.54 571	1.63 366	2.94 661	6600	0.006 0.013
13 0.5118	13 0.5118	4 0.1575	9 0.354	9.7 0.382	0.2 0.008	0.15 0.006	FP 4 13	FPL 4 13	3.74 841	4.74 1070	2.16 486	2.75 618	3.89 874	6600	0.008 0.018
14 0.5512	14 0.5512	4 0.1575	9 0.354	10.2 0.402	0.3 0.012	0.15 0.006	FP 4 14	FPL 4 14	4.05 910	5.44 1220	2.86 643	2.26 508	4.07 915	5700	0.010 0.022
15 0.5906	15 0.5906	4 0.1575	9 0.354	10.2 0.402	0.3 0.012	0.15 0.006	FP 4 15	FPL 4 15	4.05 910	5.44 1220	3.04 683	2.83 636	4.65 1040	5700	0.011 0.024

**FULL COMPLEMENT,
NON-SEPARABLE,
SEALED OR UNSEALED,
YOKE-TYPE (FG SERIES)
METRIC SERIES**

FG: crowned outer ring
FGL: cylindrical outer ring

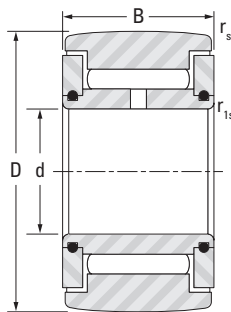

FG, FGL

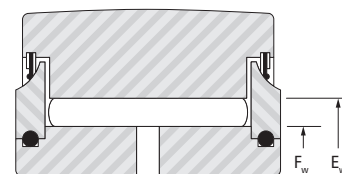

FG..EE, FG..EEM
FGL..EE, FGL..EEM

Outer Dia.	D	d	B	F _w	E _w	r _{s min}	r _{1s min}	Designation		Load Ratings					Speed Rating Grease	Wt.
								Crowned Track Roller	Cylindrical Track Roller	As a Bearing		As a Track Roller				
										Dynamic	Static	Dynamic	Static			
										C	C ₀	C _w	F _{r perm}	F _{0r perm}		
mm in.	mm in.	mm in.	mm in.	mm in.	mm in.	mm in.	mm in.			kN lbf.	kN lbf.		min ⁻¹	kg lbs.		
16 0.6299	16 0.6299	5 0.1969	12 0.472	7.7 0.3031	10.7 0.4213	0.3 0.012	0.3 0.012	FG 5 16	FGL 5 16	5.66 1270	6.51 1460	4.19 942	2.79 627	5.02 1130	5700	0.016 0.035
19 0.7480	19 0.7480	6 0.2362	12 0.472	9.7 0.3819	12.7 0.5000	0.3 0.012	0.3 0.012	FG 6 19	FGL 6 19	6.44 1450	8.15 1830	4.65 1050	3.49 785	6.28 1410	4400	0.019 0.042
24 0.9449	24 0.9449	8 0.3150	13 0.512	12.0 0.4724	15.0 0.5906	0.3 0.012	0.3 0.012	FG 8 24	FGL 8 24	7.3 1640	10.2 2290	5.45 1230	5.42 1220	8.63 1940	3500	0.037 0.082
	24 0.9449	8 0.3150	15 0.591	12.0 0.4724	15.0 0.5906	0.3 0.012	0.3 0.012	FG 8 24 15	FGL 8 24 15	9.08 2040	13.5 3030	6.76 1520	7.05 1580	11.4 2560	3500	0.044 0.097
30 1.1811	30 1.1811	10 0.3937	15 0.591	15.2 0.5984	20.2 0.7953	0.6 0.024	0.3 0.012	FG 10 30	FGL 10 30	14.2 3190	18.3 4110	10.3 2320	7.67 1720	13.8 3100	2900	0.066 0.146
32 1.2598	32 1.2598	12 0.4724	15 0.591	17.6 0.6929	22.6 0.8898	0.6 0.024	0.3 0.012	FG 12 32	FGL 12 32	15.5 3480	21.2 4770	10.5 2360	7.52 1690	13.5 3030	2400	0.077 0.170
35 1.3780	35 1.3780	15 0.5906	19 0.748	20.1 0.7929	25.2 0.9921	0.6 0.024	0.3 0.012	FG 15 35	FGL 15 35	22.5 5060	35.4 7960	14.6 3280	11.6 2610	20.9 4700	2100	0.103 0.227
40 1.5748	40 1.5748	17 0.6693	21 0.827	24.0 0.9449	30.0 1.1811	0.6 0.024	0.3 0.012	FG 17 40	FGL 17 40	29.9 6720	48.0 10800	18.5 4160	13.8 3100	24.8 5580	1800	0.155 0.342
47 1.8504	47 1.8504	20 0.7874	25 0.984	28.7 1.1299	34.7 1.3661	1.0 0.039	0.3 0.012	FG 20 47	FGL 20 47	36.5 8210	65.5 14700	22.5 5060	20.2 4540	36.4 8180	1400	0.295 0.650
52 2.0472	52 2.0472	25 0.9843	25 0.984	33.5 1.3189	39.5 1.5551	1.0 0.039	0.3 0.012	FG 25 52	FGL 25 52	39.7 8920	76.4 17200	23.1 5190	22.6 5080	40.3 9060	1200	0.310 0.683
62 2.4409	62 2.4409	30 1.1811	29 1.142	38.2 1.5039	44.2 1.7402	1.0 0.039	0.3 0.012	FG 30 62	FGL 30 62	46.5 10500	97.9 22000	28.9 6500	35.5 7980	58.2 13100	1100	0.490 1.080
72 2.8346	72 2.8346	35 1.3780	29 1.142	44.0 1.7323	50.0 1.9685	1.0 0.039	0.6 0.024	FG 35 72	FGL 35 72	50.0 11200	113 25400	31.4 7060	45.6 10300	68.4 15400	920	0.670 1.477
80 3.1496	80 3.1496	40 1.5748	32 1.260	49.7 1.9567	55.7 2.1929	1.0 0.039	0.6 0.024	FG 40 80	FGL 40 80	62.1 14000	155 38400	38.3 8610	63.7 14300	90.6 20400	810	0.890 1.962
85 3.3465	85 3.3465	45 1.7717	32 1.260	55.4 2.1811	61.4 2.4173	1.0 0.039	0.6 0.024	FG 45 85 EE	FGL 45 85	65.7 14800	173 38900	38.4 8630	67.2 15100	91.1 20500	720	0.970 2.138
90 3.5433	90 3.5433	50 1.9685	32 1.260	62.1 2.4449	68.1 2.6811	1.0 0.039	0.6 0.024	FG 50 90	FGL 50 90	69.7 15700	194 43600	37.8 8500	74.3 16700	88.7 19900	640	1.04 2.293
100 3.9370	100 3.9370	55 2.1654	36 1.417	70.0 2.7559	77.0 3.0315	1.5 0.059	0.6 0.024	FG 55 100	FGL 55 100	85.0 19100	233 52400	45.2 10200	87.9 19800	103 23200	570	1.35 2.976
110 4.3307	110 4.3307	60 2.3622	36 1.417	75.0 2.9528	82.0 3.2283	1.5 0.059	0.6 0.024	FG 60 110		88.6 19900	251 56400	48.9 11000	99.6 22400	119 26800	530	1.65 3.638
120 4.7244	120 4.7244	65 2.5591	42 1.654	80.0 3.1496	87.0 3.4252	1.5 0.059	0.6 0.024	FG 65 120	FGL 65 120	103 23200	310 69700	58.1 13100	131 29400	154 34600	490	2.35 5.181
125 4.9213	125 4.9213	70 2.7559	42 1.654	85.0 3.3465	92.0 3.6220	1.5 0.059	0.6 0.024	FG 70 125	FGL 70 125	106 23800	332 74600	58.7 13200	142 31900	157 35300	460	2.50 5.512

Continued on next page.





NEEDLE ROLLER BEARINGS

**FULL COMPLEMENT,
NON-SEPARABLE,
SEALED OR UNSEALED,
YOKE-TYPE (FG SERIES) — continued**
METRIC SERIES

B

FG: crowned outer ring
FGL: cylindrical outer ring

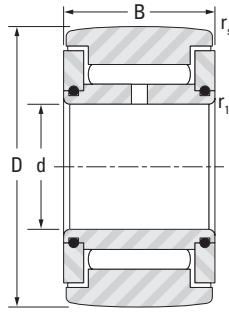

FG, FGL

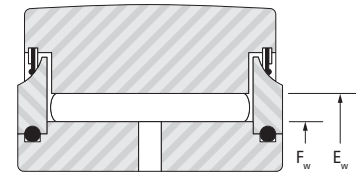

**FG..EE, FG..EEM
FGL..EE, FGL..EEM**

Outer Dia.	D	d	B	F _w	E _w	r _s min	r _{1s} min	Designation		Load Ratings					Speed Rating Grease	Wt.
								Crowned Track Roller	Cylindrical Track Roller	As a Bearing		As a Track Roller				
										Dynamic	Static	Dynamic		Static		
										C	C ₀	C _w	F _{r perm}	F _{0r perm}		
mm in.	mm in.	mm in.	mm in.	mm in.	mm in.	mm in.	mm in.			kN lbf.		min ⁻¹	kg lbs.			
130 5.1181	130 5.1181	75 2.9528	42 1.654	90.0 3.5433	97.0 3.8189	1.5 0.059	0.6 0.024	FG 75 130		110 24700	354 79600	59.2 13300	155 34800	159 35700	440	2.65 5.842
140 5.5118	140 5.5118	80 3.1496	48 1.890	100.0 3.9370	108.0 4.2520	2.0 0.079	1.0 0.039	FG 80 140	FGL 80 140	140 31500	455 102000	72.4 13600	202 45400	189 42500	390	3.40 7.496
150 5.9055	150 5.9055	85 3.3465	48 1.890	107.0 4.2126	115.0 4.5276	2.0 0.079	1.0 0.039	FG 85 150		146 32800	490 110000	75.3 16900	227 51000	203 45600	370	4.00 8.818
160 6.2992	160 6.2992	90 3.5433	54 2.126	115.0 4.5276	123.0 4.8425	2.0 0.079	1.0 0.039	FG 90 160		168 37800	603 136000	85.7 19300	299 67200	244 54900	340	5.30 11.7
170 6.6929	170 6.6929	95 3.7402	54 2.126	120.0 4.7244	128.0 5.0394	2.0 0.079	1.0 0.039	FG 95 170		172 38700	629 141000	89.8 20200	308 69200	267 60000	330	6.00 13.2
180 7.0866	180 7.0866	100 3.9370	65 2.559	126.0 4.9606	136.0 5.3543	2.0 0.079	1.5 0.059	FG 100 180		238 53500	828 186000	126 28300	358 80500	363 81600	310	8.05 17.8
200 7.8740	200 7.8740	110 4.3307	65 2.559	140.0 5.5118	150.0 5.9055	2.0 0.079	1.5 0.059	FG 110 200		252 56700	922 207000	133 29900	427 96000	401 90100	280	10.00 22.0
215 8.4646	215 8.4646	120 4.7244	65 2.559	150.0 5.9055	160.0 6.2992	2.0 0.079	1.5 0.059	FG 120 215		261 58700	985 221000	138 31000	476 107000	430 96700	260	11.50 25.3
270 10.6299	270 10.6299	150 5.9055	78 3.071	186.0 7.3228	198.0 7.7953	3.0 0.118	1.5 0.059	FG 150 270		372 83600	1470 330000	200 456000	721 162000	658 148000	210	22.00 48.5

NOTES





**FULL COMPLEMENT, NON-SEPARABLE,
LIGHT SERIES, WITH METAL SEALS
YOKE-TYPE (FGU...MM SERIES)**

METRIC SERIES

FGU: crowned outer ring
FGUL: cylindrical outer ring

FGU, FGUL

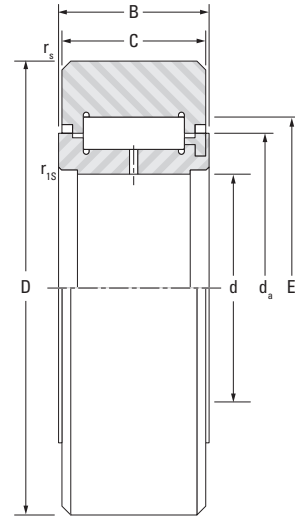

Outer Dia.	D	d	C	B	d _a	E _w	r _s min	r _{1s} min	Designation		Load Ratings			Speed Rating Grease	Wt.
									Crowned Track Roller	Cylindrical Track Roller	Dynamic		Static		
											C	F _{r perm}	F _{0r perm}		
35 1.3780	35 1.3780	15 0.5906	18 0.709	19 0.748	20.4 0.8031	28.4 1.1181	0.6 0.024	0.3 0.012	FGU 15 35		7.80 1750	17.0 3820	17.0 3820	5700	0.096 0.212
35 1.3780	35 1.3780	15 0.5906	18 0.709	19 0.748	20.4 0.8031	28.4 1.1181	0.6 0.024	0.3 0.012	FGU 15 35 MM	FGUL 15 35 MM	7.80 1750	17.0 3820	17.0 3820	5700	0.096 0.212
40 1.5748	40 1.5748	17 0.6693	20 0.787	21 0.827	23.0 0.9055	31.0 1.2205	0.6 0.024	0.3 0.012	FGU 17 40 MM		11.5 2590	20.0 4500	21.5 4830	5200	0.142 0.313
47 1.8504	47 1.8504	20 0.7874	24 0.945	25 0.984	27.1 1.0669	37.1 1.4606	1.0 0.039	0.3 0.012	FGU 20 47 MM	FGUL 20 47 MM	15.5 3480	29.5 6630	32.3 7260	4400	0.235 0.518
52 2.0472	52 2.0472	25 0.9843	24 0.945	25 0.984	31.8 1.2520	41.8 1.6457	1.0 0.039	0.3 0.012	FGU 25 52		17.3 3890	31.5 7080	36.0 8090	3800	0.268 0.591
	52 2.0472	25 0.9843	24 0.945	25 0.984	31.8 1.2520	41.8 1.6457	1.0 0.039	0.3 0.012	FGU 25 52 MM	FGUL 25 52 MM	17.3 3890	31.5 7080	36.0 8090	3800	0.268 0.591
62 2.4409	62 2.4409	30 1.1811	28 1.102	29 1.142	38.2 1.5039	50.2 1.9764	1.0 0.039	0.3 0.012	FGU 30 62 MM		24.5 5510	44.5 10000	54.00 12100	3200	0.454 1.001
72 2.8346	72 2.8346	35 1.3780	28 1.102	29 1.142	45.9 1.8071	57.9 2.2795	1.0 0.039	0.6 0.024	FGU 35 72 MM	FGUL 35 72 MM	31.3 7040	50.0 11200	66.0 14800	2700	0.611 1.347
80 3.1496	80 3.1496	40 1.5748	30 1.181	32 1.260	51.6 2.0315	63.6 2.5039	1.0 0.039	0.6 0.024	FGU 40 80		40.6 9130	59.0 13300	84.0 18900	2400	0.822 1.812
	80 3.1496	40 1.5748	30 1.181	32 1.260	51.6 2.0315	63.6 2.5039	1.0 0.039	0.6 0.024	FGU 40 80 MM	FGUL 40 80 MM	40.6 9130	59.0 13300	84.0 18900	2400	0.822 1.812
110 4.3307	110 4.3307	60 2.3622	34 1.339	36 1.417	71.2 2.8031	87.2 3.4331	1.5 0.059	0.6 0.024	FGU 60 110 MM		64.0 14400	88.0 19800	129 29000	1800	1.625 3.583
120 4.7244	120 4.7244	65 2.5591	40 1.575	42 1.654	76.4 3.0079	92.4 3.6378	1.5 0.059	0.6 0.024	FGU 65 120		89.0 20000	110 24700	174 39100	1700	2.300 5.071
	120 4.7244	65 2.5591	40 1.575	42 1.654	76.4 3.0079	92.4 3.6378	1.5 0.059	0.6 0.024	FGU 65 120 MM		89.0 20000	110 24700	174 39100	1700	2.300 5.071
125 4.9213	125 4.9213	70 2.7559	40 1.575	42 1.654	81.5 3.2087	97.5 3.8386	1.5 0.059	0.6 0.024	FGU 70 125 MM		93.0 20900	110 24700	180 40500	1600	2.070 4.564
140 5.5118	140 5.5118	80 3.1496	46 1.811	48 1.890	91.7 3.6102	107.7 4.2402	2.0 0.079	1.0 0.039	FGU 80 140 MM		130 29200	138 31000	250 56200	1400	3.450 7.606
160 6.2992	160 6.2992	90 3.5433	52 2.047	54 2.126	101.8 4.0079	121.8 4.7953	2.0 0.079	1.0 0.039	FGU 90 160 MM		166 37300	188 42300	327 73500	1300	5.185 11.431
170 6.6929	170 6.6929	95 3.7402	52 2.047	54 2.126	108.2 4.2598	128.2 5.0472	2.0 0.079	1.0 0.039	FGU 95 170 MM		184 41400	198 44500	356 80000	1200	5.925 13.062
200 7.8740	200 7.8740	110 4.3307	63 2.480	65 2.559	124.1 4.8858	144.1 5.6732	2.0 0.079	1.5 0.059	FGU 110 200 MM		310 69700	280 62900	590 132600	1100	10.200 22.487
215 8.4646	215 8.4646	120 4.7244	63 2.480	65 2.559	133.6 5.2598	157.6 6.2047	2.0 0.079	1.5 0.059	FGU 120 215		310 69700	310 69700	600 134900	960	11.560 25.485

**FULL COMPLEMENT, NON-SEPARABLE,
HEAVY SERIES, WITH METAL SEALS
YOKE-TYPE (FGU...MM SERIES)
METRIC SERIES**

FGU: crowned outer ring
FGUL: cylindrical outer ring

FGU, FGUL

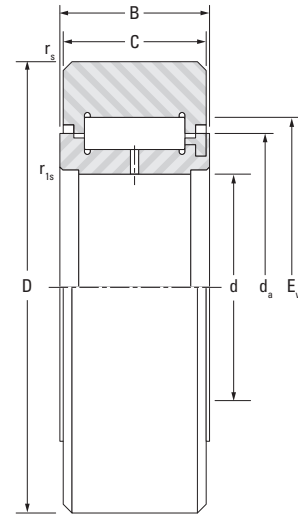

Outer Dia.	D	d	C	B	d _a	E _w	r _s min	r _{1s} min	Designation		Load Ratings				Speed Rating Grease	Wt.	
									Crowned Track Roller	Cylindrical Track Roller	As a Bearing		As a Track Roller				
											Dynamic	Static	Dynamic				Static
											C	C ₀	C _w	F _{r perm}			F _{0r perm}
mm in.	mm in.	mm in.	mm in.	mm in.	mm in.	mm in.	mm in.			kN lbf.	kN lbf.	kN lbf.	min ⁻¹	kg lbs.			
42 1.6535	42 1.6535	15 0.5906	18 0.709	19 0.748	20.4 0.8031	28.4 1.1181	1.0 0.039	0.3 0.012	FGU 15 42	FGUL 15 42 MM	26.4 5930	32.4 7280	19.7 4430	14.7 3300	26.4 5930	2200	0.153 0.337
47 1.8504	47 1.8504	17 0.6693	20 0.787	21 0.827	20.0 0.7874	28.0 1.1024	1.0 0.039	0.3 0.012	FGU 17 47 MM	FGUL 17 47 MM	28.3 6360	36.5 8210	21.5 4830	18.8 4230	31.9 7170	1900	0.214 0.472
52 2.0472	52 2.0472	20 0.7874	24 0.945	25 0.984	27.1 1.0669	37.1 1.4606	1.0 0.039	0.3 0.012	FGU 20 52 MM	FGUL 20 52 MM	43.8 9850	57.9 13000	30.7 6900	21.3 4790	38.3 8610	1600	0.268 0.591
62 2.4409	62 2.4409	25 0.9843	24 0.945	25 0.984	31.8 1.2520	41.8 1.6457	1.0 0.039	0.3 0.012	FGU 25 62		48.2 10800	68.2 15300	35.1 7890	30.7 6900	55.1 12400	1400	0.435 0.959
72 2.8346	72 2.8346	30 1.1811	28 1.102	29 1.142	38.2 1.5039	50.2 1.9764	1.0 0.039	0.3 0.012	FGU 30 72 MM	FGUL 30 72 MM	70 15700	103 23200	49 11000	40 8990	72 16200	1100	0.681 1.501
80 3.1496	80 3.1496	35 1.3780	28 1.102	29 1.142	45.9 1.8071	57.9 2.2795	1.0 0.039	0.6 0.024	FGU 35 80	FGUL 35 80	77.5 17400	124 27900	51 11500	42.4 9530	76.3 17200	920	0.82 1.808
	80 3.1496	35 1.3780	28 1.102	29 1.142	45.9 1.8071	57.9 2.2795	1.0 0.039	0.6 0.024	FGU 35 80 MM		77.5 17400	124 27900	51 11500	42.4 9530	76.3 17200	920	0.82 1.808
90 3.5433	90 3.5433	40 1.5748	30 1.181	32 1.260	51.6 2.0315	63.6 2.5039	1.0 0.039	0.6 0.024	FGU 40 90 MM		89.2 20100	153 34400	60.2 13500	59.3 13300	107 24100	810	1.125 2.480
100 3.9370	100 3.9370	45 1.7717	30 1.181	32 1.260	55.4 2.1811	67.4 2.6535	1.5 0.059	0.6 0.024	FGU 45 100 MM		92.7 20800	165 37100	64.5 14500	73.6 16500	122 27400	750	1.395 3.075
110 4.3307	110 4.3307	50 1.9685	30 1.181	32 1.260	61.1 2.4055	73.1 2.8780	1.5 0.059	0.6 0.024	FGU 50 110		97.8 22000	182 40900	68.1 15300	85.9 19300	135 30300	680	1.683 3.710
	110 4.3307	50 1.9685	30 1.181	32 1.260	61.1 2.4055	73.1 2.8780	1.5 0.059	0.6 0.024	FGU 50 110 MM		97.8 22000	182 40900	68.1 15300	85.9 19300	135 30300	680	1.683 3.710
120 4.7244	120 4.7244	55 2.1654	34 1.339	36 1.417	66.1 2.6024	82.1 3.2323	1.5 0.059	0.6 0.024	FGU 55 120		128 28800	215 48300	88.7 19900	91.8 20600	159 35700	640	2.235 4.927
	120 4.7244	55 2.1654	34 1.339	36 1.417	66.1 2.6024	82.1 3.2323	1.5 0.059	0.6 0.024	FGU 55 120 MM	FGUL 55 120 MM	128 28800	215 48300	88.7 19900	91.8 20600	159 35700	640	2.235 4.927
130 5.1181	130 5.1181	60 2.3622	34 1.339	36 1.417	71.2 2.8031	87.2 3.4331	1.5 0.059	0.6 0.024	FGU 60 130 MM		133 29900	232 52200	93.4 21000	106 23800	175 39300	590	2.62 5.776
140 5.5118	140 5.5118	65 2.5591	40 1.575	42 1.654	76.4 3.0079	92.4 3.6378	2.0 0.079	0.6 0.024	FGU 65 140 MM		156 35100	290 65200	110 24700	142 31900	222 49900	540	3.56 7.848

Continued on next page.



NEEDLE ROLLER BEARINGS

FULL COMPLEMENT, NON-SEPARABLE, HEAVY SERIES, WITH METAL SEALS YOKE-TYPE (FGU...MM SERIES) – *continued* METRIC SERIES

FGU, FGUL

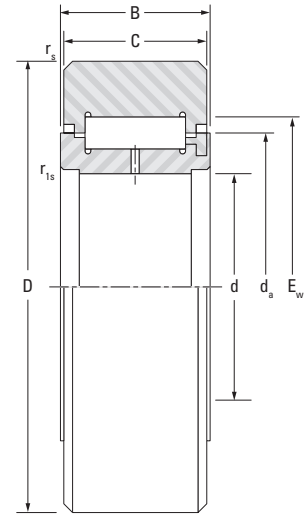

FGU: crowned outer ring
FGUL: cylindrical outer ring

Outer Dia.	D	d	C	B	d _a	E _w	r _s min	r _{1s} min	Designation		Load Ratings					Speed Rating Grease	Wt.
									Crowned Track Roller	Cylindrical Track Roller	As a Bearing		As a Track Roller				
											Dynamic	Static	Dynamic		Static		
											C	C ₀	C _w	F _{T perm}	F _{0r perm}		
mm in.	mm in.	mm in.	mm in.	mm in.	mm in.	mm in.	mm in.			kN lbf.	kN lbf.	kN lbf.	min ⁻¹	kg lbs.			
150 5.9055	150 5.9055	70 2.7559	40 1.575	42 1.654	81.5 3.2087	97.5 3.8386	2.0 0.079	0.6 0.024	FGU 70 150 MM		161 36200	310 69700	115 25900	160 36000	240 54000	510	4.09 9.017
160 6.2992	160 6.2992	75 2.9528	40 1.575	42 1.654	86.6 3.4094	102.6 4.0394	2.0 0.079	0.6 0.024	FGU 75 160		166 37300	329 74000	119 26800	178 40000	257 57800	480	4.65 10.3
	160 6.2992	75 2.9528	40 1.575	42 1.654	86.6 3.4094	102.6 4.0394	2.0 0.079	0.6 0.024	FGU 75 160 MM		166 37300	329 74000	119 26800	178 40000	257 57800	480	4.65 10.3
170 6.6929	170 6.6929	80 3.1496	46 1.811	48 1.890	91.7 3.6102	107.7 4.2402	2.0 0.079	1.0 0.039	FGU 80 170		195 43800	412 92600	140 31500	229 51500	322 72400	450	6.07 13.4
	170 6.6929	80 3.1496	46 1.811	48 1.890	91.7 3.6102	107.7 4.2402	2.0 0.079	1.0 0.039	FGU 80 170 MM		195 43800	412 92600	140 31500	229 51500	322 72400	450	6.07 13.4
180 7.0866	180 7.0866	85 3.3465	46 1.811	48 1.890	95.5 3.7598	115.5 4.5472	2.0 0.079	1.0 0.039	FGU 85 180		224 50400	426 95800	162 36400	225 50600	340 76400	440	6.724 14.8
	180 7.0866	85 3.3465	46 1.811	48 1.890	95.5 3.7598	115.5 4.5472	2.0 0.079	1.0 0.039	FGU 85 180 MM	FGUL 85 180 MM	224 50400	426 95800	162 36400	225 50600	340 76400	440	6.724 14.8
190 7.4803	190 7.4803	90 3.5433	52 2.047	54 2.126	101.8 4.0079	121.8 4.7953	2.0 0.079	1.0 0.039	FGU 90 190 MM		259 58200	524 118000	186 41800	277 62300	412 92600	410	8.515 18.8
260 10.2362	260 10.2362	120 4.7244	63 2.480	65 2.559	133.6 5.2598	157.6 6.2047	3.0 0.118	1.5 0.059	FGU 120 260 MM		396 89000	875 197000	293 65900	540 121000	730 164000	300	19.750 43.6
300 11.8110	300 11.8110	140 5.5118	75 2.953	78 3.071	152.6 6.0079	176.6 6.9528	3.0 0.118	1.5 0.059	FGU 140 300 MM		493 111000	1210 272000	367 82500	818 184000	1020 229000	260	31.265 68.9

**FULL COMPLEMENT,
WITHOUT INNER RING,
UNSEALED, YOKE-TYPE
(RNA...B6, RNAB, RNAL SERIES)**

**SEPARATE INNER RINGS
(BIC SERIES)
METRIC SERIES**

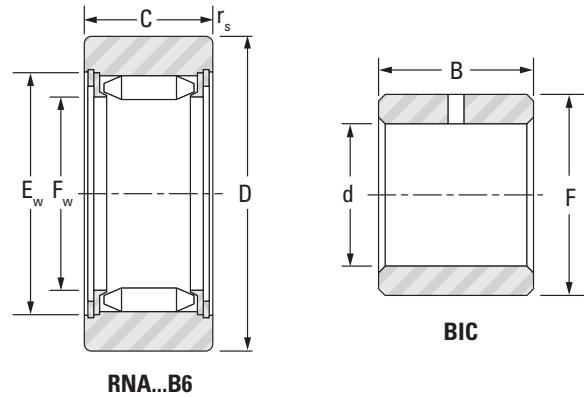

RNA...B6: Crowned outer ring to maximum slope of 0.15%. Tolerance h9 on dimension D.
 RNAB: Crowned outer ring to maximum slope of 1.5%. Tolerance h9 on dimension D.
 RNAL: Cylindrical outer ring. Tolerance h7 on dim. D.

Outer Dia.	D	C	F _w	E _w	r _{smin}	Track Roller Designations			Load Ratings					Speed Rating Grease	Wt.	Inner Ring Designation	F	B	d	r _{ts min}	Shaft Dia.
									As a Bearing		As a Track Roller										
						RNA...B6	RNAB	RNAL	Dynamic	Static	Dynamic	Static	Static								
mm in.	mm in.	mm in.	mm in.	mm in.	mm in.			C	C ₀	C _w	F _{R perm}	F _{0r perm}	min ⁻¹	kg lbs.						mm in.	
19 0.7480	19 0.7480	12 0.472	7.3 0.287	12.3 0.484	0.35 0.014	RNA 11005 B6	RNAB 11005		5.31 1190	4.44 998	4.82 1080	4.44 998	4.82 1080	6500	0.019 0.042						
22 0.8661	22 0.8661	12 0.472	9.7 0.382	14.7 0.579	0.35 0.014	RNA 11007 B6	RNAB 11007	RNAL 11007	6.42 1440	5.93 1330	5.5 1240	5.26 1180	6.55 1470	4700	0.022 0.049						
28 1.1024	28 1.1024	12 0.472	12.1 0.476	17.1 0.673	0.35 0.014	RNA 11009 B6	RNAB 11009	RNAL 11009	7.37 1660	7.42 1670	6.66 1500	7.42 1670	9.06 2040	3700	0.028 0.062						
32 1.2598	32 1.2598	15 0.591	17.6 0.693	22.6 0.890	0.35 0.014	RNA 11012 B6	RNAB 11012	RNAL 11012	12.7 2850	16.4 3690	9.38 2110	9.48 2130	13.7 3080	2400	0.032 0.071	BIC 1012	17.6 0.693	15 0.591	12 0.472	0.35 0.014	12 0.472
35 1.3780	35 1.3780	15 0.591	20.8 0.819	25.8 1.016	0.65 0.026	RNA 11015 B6	RNAB 11015		13.9 3120	19.4 4360	9.60 2160	9.47 2130	14.1 3170	2000	0.035 0.077	BIC 1015	20.8 0.819	15 0.591	15 0.591	0.65 0.026	15 0.591
42 1.6535	42 1.6535	15 0.591	23.9 0.941	28.9 1.138	0.65 0.026	RNA 11017 B6	RNAB 11017	RNAL 11017	15.0 3370	22.4 5040	11.0 2470	14.4 3240	18.4 4140	1700	0.042 0.093	BIC 1017	23.9 0.941	15 0.591	17 0.669	0.68 0.026	17 0.669
47 1.8504	47 1.8504	18 0.709	28.7 1.130	34.7 1.366	0.65 0.026	RNA 11020 B6	RNAB 11020	RNAL 11020	21.7 4880	33.5 7530	14.6 3280	16.0 3600	23.3 5240	1400	0.047 0.104	BIC 2020	28.7 1.130	18 0.709	20 0.787	0.65 0.026	20 0.787
52 2.0472	52 2.0472	18 0.709	33.5 1.319	39.5 1.555	0.65 0.026	RNA 11025 B6	RNAB 11025		23.6 5310	39.1 8790	15.0 3370	17.1 3840	24.4 5490	1200	0.052 0.115	BIC 1025	33.5 1.319	18 0.709	25 0.984	0.65 0.026	25 0.984
62 2.4409	62 2.4409	22 0.866	38.2 1.504	44.2 1.740	0.65 0.026	RNA 11030 B6	RNAB 11030		34.2 7690	65.8 14800	22.6 5080	32.8 7370	44.3 9960	1100	0.062 0.137	BIC 2030	38.2 1.504	22 0.866	30 1.181	0.65 0.026	30 1.181
72 2.8346	72 2.8346	22 0.866	44.0 1.732	50.0 1.969	0.65 0.026	RNA 11035 B6			36.7 8250	75.7 17000	24.6 5530	42.4 9530	52.2 11700	920	0.072 0.159	BIC 2035	44 1.732	22 0.866	35 1.378	0.65 0.026	35 1.378
80 3.1496	80 3.1496	22 0.866	49.7 1.957	55.7 2.193	0.85 0.033		RNAB 11040		39.2 8810	85.6 19200	25.8 5800	48.7 10900	57.0 12800	810	0.080 0.176	BIC 2040	49.7 1.957	22 0.866	40 1.575	0.85 0.033	40 1.575
90 3.5433	90 3.5433	24 0.945	62.1 2.445	68.1 2.681	0.85 0.033	RNA 11050 B6			44.0 9890	107 24100	25.8 5800	53.1 11900	57.0 12800	640	0.090 0.198	BIC 11050	62.1 2.445	24 0.945	50 1.969	0.85 0.033	50 1.969



STUD-TYPE AND YOKE-TYPE TRACK ROLLERS – FULL COMPLEMENT

INCH SERIES

Inch series track rollers listed in this catalog have been designed with the outer rings of large radial cross section to withstand heavy rolling or shock loads on track-type or cam-controlled equipment.

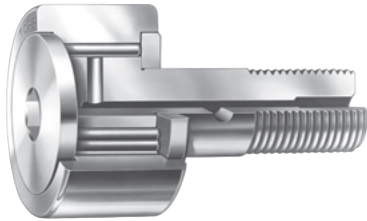

Fig. B-61. CR with stud



Fig. B-62. YCR for yoke mounting

REFERENCE STANDARD:

- **ANSI/ABMA Std. 18.2** – needle roller bearings – radial, inch design.

Before selecting specific inch series track rollers, the engineering section in this catalog should be reviewed.

IDENTIFICATION

The stud- and yoke-type, special construction features and size are designated by an identification code consisting of prefix letters followed by a dash and suffix numbers.

The initial prefix letters denote the type of track roller/cam follower. Additional prefix letters are used when it is necessary to denote special construction features. The suffix numbers following the prefix letters denote the size of the track roller. See Table B-38.

The basic types are listed below:

CR – regular stud-type, full complement needle rollers, inch series

YCR – yoke-type, full complement needle rollers, inch series

Construction feature code letters – for inch series track rollers – are used as required, in the following order:

- S – seals with internal thrust washers
- B – hexagonal wrench socket in stud head (stud-type only)
- C – crowned outer ring
- E – eccentric stud (stud-type only)

Descriptions of typical examples, with complete letter codes, combining basic type of bearing and construction features follow. See Table B-39.

Since the entire identification code might not appear on the bearing itself, the manufacturer’s parts list or another reliable source should always be consulted when ordering bearings for field or service replacement to make certain the correct unit with the correct lubricant is specified.

Table B-38. Identification code – inch series

Type	Prefix letters		Suffix numbers			Complete
	Plus	Construction features	Plus size	O.D.	Equals	Designation
CR	plus	SBE	plus	-16	equals	CRSBE-16
CR	plus			-16	equals	CR-16

Table B-39. Code description – inch series

Stud-types	
Description	Prefix code
With seals and internal thrust washers	CRS
With seals, internal thrust washers and crowned outer ring	CRSC
With seals, internal thrust washers, hex socket and crowned outer ring	CRSBC
With seals, internal thrust washers, hex socket, crowned outer ring and eccentric stud	CRSBCE
Yoke-types	
With seals and internal thrust washers	YCRS
With seals, internal thrust washers and profiled outer ring	YCRSC

CONSTRUCTION

JTEKT products listed on the following pages have been designed with the outer ring of the large radial cross section to withstand heavy rolling and shock loads on track-type or cam-controlled equipment.

Regular stud-type (CR) are designed with integral studs for cantilever mounting. When a regular stud-type track roller is used within the permissible dynamic load ($F_{r\text{ perm}}$) given in the bearing tables, the ductile core of the stud provides the necessary toughness for and resistance to shock loads. A screwdriver slot or a hexagonal wrench socket, in the head of the stud, facilitates mounting.

Yoke-type (YCR) are designed for straddle mounting. Each type is available with a full complement of needle rollers.

All inch series track rollers have a black-oxide finish on all external surfaces.

SEALED TRACK ROLLERS – INCH SERIES

Inch series sealed track rollers contain a lip-type seal and an internal thrust washer. On some sizes of track rollers, the thrust washer and seal have been incorporated into a single component. Regardless of configuration, the thrust washer fits between the shoulders of the outer ring. The inside faces the steel retaining washer and flange of the stud. These washers reduce sliding friction and serve to increase the life of the bearing – particularly when it is infrequently re-lubricated, or where misalignment occurs. In all cases, the external dimensions of the sealed bearings are the same as the unsealed bearings. The seals are thermally stable in a temperature range between -30°C and $+110^{\circ}\text{C}$ (-25°F and $+225^{\circ}\text{F}$).

CROWNED TRACK ROLLERS

These units are available with cylindrical or crowned outer rings.

Track rollers are designed with a crowned outer ring to alleviate the uneven bearing loading – resulting from deflection, bending or misalignment in mounting.

To specify a crowned ring for any inch series track roller having a cylindrical outer ring, add the letter “C” at the end of the prefix code. For example:

- prefix CR** – regular stud-type, full complement of needle rollers and cylindrical outer ring
- prefix CRC** – same as above, but with crowned outer ring.

The O.D. tolerance of crowned track rollers is 0.000 – 0.050 mm (+0.0000 - 0.0020 inch). The crown radii are listed in Table B-40.

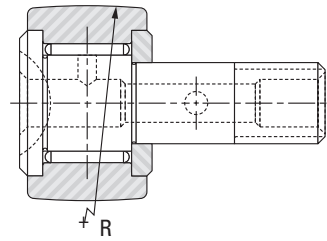

Fig. B-63. CR with stud

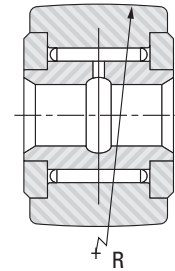

Fig. B-64. YCR for yoke mounting

Table B-40. Crown radius for types CRC, CRSC, CRSBC, YCRC, YCRSC

Size designation (suffix)	R		Size designation (suffix)	R	
	Crown radius (approx.)			Crown radius (approx.)	
	mm	in.		mm	in.
-8	152.400	6.0000	-28	508.000	20.0000
-8-1	177.800	7.0000	-30	508.000	20.0000
-10	177.800	7.0000	-32	609.600	24.0000
-10-1	203.200	8.0000	-36	609.600	24.0000
-12	254.000	10.0000	-40	762.000	30.0000
-14	254.000	10.0000	-44	762.000	30.0000
-16	304.800	12.0000	-48	762.000	30.0000
-18	304.800	12.0000	-52	762.000	30.0000
-20	355.600	14.0000	-56	762.000	30.0000
-22	355.600	14.0000	-64	762.000	30.0000
-24	508.000	20.0000			
-26	508.000	20.0000			

HEXAGONAL SOCKETS

Smaller sizes of regular inch series stud-type units have a screwdriver slot or a hexagonal socket in the flanged end of the stud to facilitate mounting. Larger sizes have a socket to accommodate a hexagonal wrench. Wrench sizes are listed in Table B-41 on page B-254.

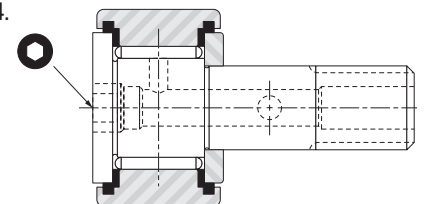

Fig. B-65. Inch series stud-type unit with hexagonal socket



Table B-41. Hexagonal wrench sizes – inch series

Size designation (suffix)	Wrench size	Size designation (suffix)	Wrench size
	mm in.		mm in.
-8	3.175 0.1250	-28	7.937 0.3125
-8-1	3.175 0.1250	-30	7.937 0.3125
-10	3.175 0.1250	-32	11.112 0.4375
-10-1	3.175 0.1250	-36	11.112 0.4375
-12	4.762 0.1875	-40	12.700 0.5000
-14	4.762 0.1875	-44	12.700 0.5000
-16	6.350 0.2500	-48	19.050 0.7500
-18	6.350 0.2500	-52	19.050 0.7500
-20	6.350 0.2500	-56	19.050 0.7500
-22	6.350 0.2500	-64	19.050 0.7500
-24	7.937 0.3125	-80	22.225 0.875
-26	7.937 0.3125	-96	25.40 1.000

ECCENTRIC STUDS

To provide radial adjustment of the outer ring toward the track or cam surface at the time of installation, the regular inch series stud-types are available with eccentric studs which are specified by adding the letter “E” to the construction feature code:

prefix CRSBE – regular stud-type track roller with full complement of needle rollers, two seals, with internal thrust washers, hexagonal wrench socket in stud head, and eccentric stud.

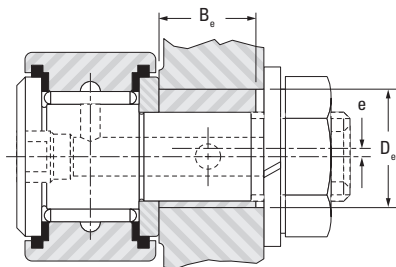

Fig. B-66. Eccentric studs – inch series

Pertinent dimensions of the eccentric stud are listed in Table B-42.

Since a track roller with an eccentric stud is usually adjusted upon installation by turning the stud in the mounting hole, a close clearance fit between the outer diameter of the bushing and the mounting hole is necessary. For turning the stud, a hexagonal

wrench is generally more convenient than a screwdriver. And an option for a hexagonal wrench socket, in the head of the stud, should be exercised.

Some applications may require more secure positioning than provided by the tightened stud nut. If so, it is suggested that the housing, and eccentric bushing, be drilled at the time of installation to accept a locating dowel pin.

Table B-42. Eccentric bushing dimensions regular stud-type (type CR)

Size designation (suffix)	D _e	B _e	e
	Bushing O.D. +0.001, -0.001	Bushing width +0.000, -0.010	Eccentricity
	mm in.	mm in.	mm in.
-8-1	6.350 0.250	9.525 0.375	0.254 0.010
-10-1	9.525 0.375	11.100 0.437	0.381 0.015
-12	12.700 0.500	12.700 0.500	0.381 0.015
-14	12.700 0.500	12.700 0.500	0.381 0.015
-16	15.875 0.625	12.700 0.500	0.762 0.030
-18	15.875 0.625	12.700 0.500	0.762 0.030
-20	17.450 0.687	15.875 0.625	0.762 0.030
-22	17.450 0.687	15.875 0.625	0.762 0.030
-24	22.225 0.875	19.050 0.750	0.762 0.030
-26	22.225 0.875	19.050 0.750	0.762 0.030
-28	25.400 1.000	22.225 0.875	0.762 0.030
-30	25.400 1.000	22.225 0.875	0.762 0.030
-32	30.150 1.187	25.400 1.000	0.762 0.030
-36	30.150 1.187	25.400 1.000	0.762 0.030
-40	34.925 1.375	28.575 1.125	0.762 0.030
-44	34.925 1.375	28.575 1.125	0.762 0.030
-48	44.450 1.750	31.750 1.250	1.524 0.060
-52	44.450 1.750	31.750 1.250	1.524 0.060
-56	46.025 1.812	34.925 1.375	1.524 0.060
-64	50.800 2.000	50.800 2.000	1.524 0.060

- To ensure proper clamping of the stud, the housing should be slightly wider than the maximum width of the eccentric bushing.

- Diameter of bushing mounting hole should be D_E plus 0.002/0.003 in. (.051-0.0102mm).

LOAD RATINGS

DYNAMIC LOADING AS A TRACK ROLLER

When the outer ring of a stud-type or yoke-type track roller runs on a track, the contact under a radial load causes elastic (oval) deformation of the outer ring. As a result, a smaller zone of the raceway is loaded and the load is distributed on fewer needle rollers. This, in turn, affects the track roller's dynamic and static load ratings. Also, this deformation generates bending stress in the outer ring, which must not exceed the maximum permitted for the material of the outer ring. The maximum permissible dynamic ($F_{r\text{ perm}}$) radial load condition is determined by this requirement.

The rating life of a stud-type or yoke-type track roller should be calculated using the dynamic load ratings, C_w , shown in the tables. The tables also show the maximum permissible radial load, $F_{r\text{ perm}}$, that can be dynamically applied on the stud-type or yoke-type track rollers. However, to calculate the L_{10} life of a track roller, the applied radial load must not be greater than $C_w/4$ – based on ideal operating conditions of alignment, lubrication, temperature, speed and accelerations.

STATIC LOADING

In addition to the basic static load rating C_0 , the tables also list the maximum permissible static radial load, $F_{0r\text{ perm}}$, that may be applied to a stud-type or yoke-type track roller. The values of $F_{0r\text{ perm}}$ result in a minimum static factor f_s of 0.7, for the worst condition of internal load distribution in inch series track roller operation. **The $F_{0r\text{ perm}}$ values must not be exceeded.** Exceeding $F_{0r\text{ perm}}$ may cause permanent damage to the track roller. A damaged track roller could cause the equipment in which the track roller is installed to malfunction. The static factor f_s can be calculated using the following formula:

$$f_s \geq 0.7 \left(\frac{F_{0r\text{ perm}}}{P_{0r}} \right)$$

Where:

- $F_{0r\text{ perm}}$ = Maximum permissible static radial load
- P_{0r} = Equivalent static load
(F_{0r} for yoke-type track rollers)
- F_{0r} = Static radial load
- f_s = Static factor whose values should not be smaller than those suggested in Table B-43.

Table B-43. Suggested values for static factors f_s for inch series track rollers

Requirements for yoke – type track rollers and stud – type track rollers	Suggested f_s values	
	Max.	Min.
High shock-type loads – Quiet running	1.5	2.5
Normal loading – Normal quietness of running	1	1.5
Minor impact loads and rotary motion particularly quiet running not required	0.7	1

MOUNTING

The surface of the hole in the machine element, which supports the stud or the mounting shaft, must not deform under the expected load, and the support should be sufficiently rigid to resist bending loads.

Deformation and bending will cause uneven loading of the outer ring.

In mounting the stud-type track roller, the retaining washer must be firmly backed up by a flat shoulder which is square with the stud center line. The shoulder diameter must be no smaller than the minimum clamping diameter (d_a) listed in the bearing tables.

The maximum inherent strength of the stud is obtained when the unit is supported, as close as possible, to the retaining washer – which minimizes the bending moment. For this reason, the edge of the housing, which supports the stud shank, should be kept as sharp as possible, but free from burrs.

To minimize deflection in mounted stud-type track rollers, the stud shank should be housed with the fit (d_b) shown in the bearing tables. The clamping nut should not be tightened with a torque value higher than the maximum listed. A screwdriver slot, or hexagonal socket in the end of the stud, is provided for a tool to prevent the stud from turning when the nut is being tightened. Because the bottom of the screwdriver slot is not flat, it is helpful to put a radius on the tip of the screwdriver being used to hold the stud more securely.

When the stud shank is housed with an interference fit, installation force should be applied only to the center portion of the flanged end of the stud, preferably with an arbor press.

When the loads are high, the yoke-type track rollers should be mounted on a high strength bolt or shaft with the tight transition fit listed in the bearing tables. The bearing should be clamped between flat and parallel faces, at right angles, to the axis to prevent the retaining washers from coming off under load. If the bearing cannot be clamped, a close axial fit in the yoke is required.

When the applied loads are light to moderate, the inner ring of a yoke-type track roller may be mounted on an unhardened shaft, or a bolt with the loose transition fit listed in the bearing tables. Again, the retaining washers should be backed up axially to prevent their coming off under load.



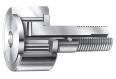

LUBRICATION

All inch series stud-type track rollers with a screwdriver slot in the flanged end of the stud have provisions for lubrication, through the flanged end of the stud. The 12, and larger sizes of inch series stud-type track rollers with screwdriver slots, have provisions for re-lubrication through either end of the stud, and through a cross-drilled hole in the shank. The ends of the axial holes are counterbored to accept drive-type grease lubrication fittings. Hole diameters for these grease fittings are listed in the tables of dimensions.

Sizes 8 through 10-1 of the inch series stud-type track rollers, with a hexagonal socket in the flanged end of the stud, cannot be re-lubricated. Size 12 and up have re-lubrication provisions in the threaded end of the stud, and a cross-drilled hole in the shank. At the threaded end of the stud, the axial hole is counterbored to receive a drive type grease fitting. Sizes 12 through 22 and 48 through 64 of inch series stud-type track rollers, with hexagonal sockets, also have provisions for re-lubrication through the hex socket in the flanged end of the stud. Sizes 48 through 64 are supplied with lubrication fittings which may be installed in the axial hole in the bottom of the hexagonal slot in the head end of the stud – at a depth which allows the hexagonal wrench to be inserted in the wrench socket, without damaging the grease fitting.

Plugs are furnished with stud-type track rollers to close off unused holes. If the cross-drilled hole in the stud shank is not used, it will be covered when the track roller is installed properly.

Most inch series yoke-type track rollers are produced with lubrication holes and grooves in the inner ring bores, so they can be re-lubricated through axially and radially drilled holes in the supporting shaft or bolt.

Oil is the preferred lubricant for all types. Use continuous oil lubrication, or frequent grease lubrication for steady rotating conditions. Applications involving slow, intermittent oscillation are not as critical. And longer intervals between re-lubrication are permissible. Both stud- and yoke-type track rollers are normally supplied with medium temperature grease lubrication.

SPECIAL TRACK ROLLERS/ CAM FOLLOWERS

Track rollers can be obtained with dimensions different from those in the bearing tables, if the quantities permit economical production. For these and other modifications, please consult your representative.

B



FORKLIFT TRUCK

Yoke-type sealed units serve as high capacity and rugged guide rollers for lift trucks. Their design permits them to be mounted on studs welded to the structure. The seals exclude foreign matter and extend the time between re-lubrication periods.

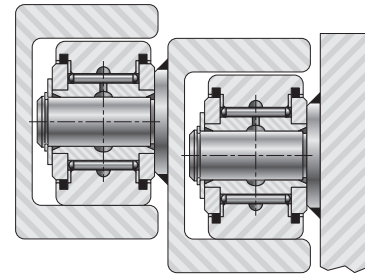

Fig. B-67. Yoke-type sealed units

HAY BALER

Stud-types are important components on many different types of farm equipment because of their required long service life under severe loads and operating conditions. Needle roller bearings provide dependable and economical operation in the windrow pickup of hay balers.

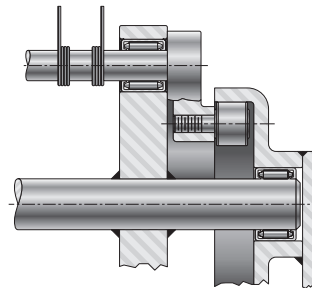

Fig. B-68. Stud-type

MACHINE WAY

Heavily loaded machine tool tables must travel freely and accurately. Stud- and yoke-type sealed units, in combination, support and guide such tables under the most severe conditions. The high capacity and the very low wear rate permit heavy loads to be carried without impairing the accuracy of the table's travel. The seals exclude dirt and chips, and make the need for re-lubrication infrequent.

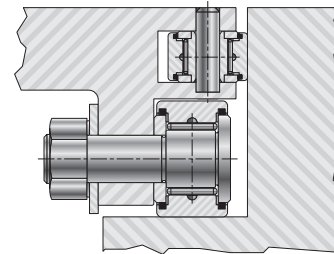

Fig. B-69. Stud- and yoke-type sealed units

RECIPROCATING SLIDE

Stud-types find wide application in feeding and advancing mechanisms on metalworking presses. The rotary motion of an eccentric cam, rotating between two cam followers, mounted on a slide imparts reciprocating linear motion to the slide. Dwell periods, as well as accuracy in both rapid and slow linear actuation of the slide, are made possible.

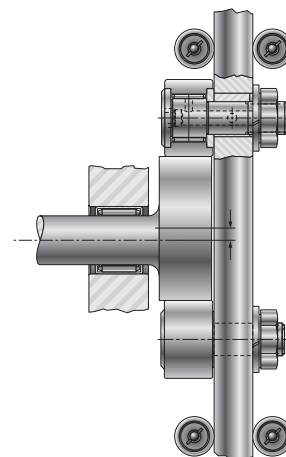

Fig. B-70. Stud-type





STUD-TYPE TRACK ROLLERS

CR, CRS SERIES

INCH SERIES

- Screwdriver slot in head facilitates mounting.
- Non-separable, sealed unit with outer ring, full complement of needle rollers, stud seals, self-lubricating resin internal thrust washers, and stud-fastened retaining washer.
- Seals help retain lubricant and exclude foreign matter (CRS Series).
- Re-lubrication via axially drilled hole through stud with cross-drilled holes in stud raceway and shank.
- Recessed axial hole accepts standard nominal inch drive-type grease lubrication fitting.
- Lubrication fitting plugs furnished to close off unused holes.
- Tolerance limits for outer diameters of stud and outer ring refer to "single mean diameter."
- A close fit between stud and hole required for mounting.
- Bore dimensions given below result in varying fit (0.025 mm tight to 0.013 mm loose [0.0010 in. tight to 0.0005 in. loose]).
- Retaining washer should be firmly backed up by flat housing shoulder (perpendicular to the stud axis).
- Shoulder diameter should be at least same size as minimum clamping diameter listed.
- May be mounted with two thin lock nuts, or nut and lock washer.

Outer Dia.	d ₁	D	C	B ₂	B ₃	G ₁	d ₂ and d ₄	d ₃	G	Track Roller Designation	
	+0.025 +0.0010 -0 -0.0000	+0 +0.000 -0.025 -0.001	+0 +0.000 -0.13 -0.005	(nom.)		Min.			UNF	Without Seals	With Seals and Internal Thrust Washers
in.	mm in.	mm in.	mm in.	mm in.	mm in.	mm in.	mm in.	mm in.	in.		
1/2	4.826 0.1900	12.70 0.500	8.74 0.344	12.70 0.500	—	6.35 0.250	3.18 ⁽²⁾ 0.125 ⁽¹⁾	—	10-32	CR-8	CRS-8
	4.826 0.1900	12.70 0.500	9.53 0.375	15.88 0.625	—	6.35 0.250	3.18 ⁽²⁾ 0.125 ⁽¹⁾	—	10-32	CR-8-1	CRS-8-1
5/8	6.350 0.2500	15.88 0.625	10.31 0.406	15.88 0.625	—	7.92 0.312	3.18 ⁽²⁾ 0.125 ⁽¹⁾	—	1/4-28	CR-10	CRS-10
	6.350 0.2500	15.88 0.625	11.13 0.438	19.05 0.750	—	7.92 0.312	3.18 ⁽²⁾ 0.125 ⁽¹⁾	—	1/4-28	CR-10-1	CRS-10-1
3/4	9.525 0.3750	19.05 0.750	12.70 0.500	22.23 0.875	6.35 0.250	9.53 0.375	3.18 0.188	2.39 0.094	3/8-24	CR-12	CRS-12
7/8	9.525 0.3750	22.23 0.875	12.70 0.500	22.23 0.875	6.35 0.250	9.53 0.375	3.18 0.188	2.39 0.094	3/8-24	CR-14	CRS-14
1	11.113 0.4375	25.40 1.000	15.88 0.625	25.40 1.000	6.35 0.250	12.70 0.500	3.18 0.188	2.39 0.094	7/16-20	CR-16	CRS-16
1 1/8	11.113 0.4375	28.58 1.125	15.88 0.625	25.40 1.000	6.35 0.250	12.70 0.500	3.18 0.188	2.39 0.094	7/16-20	CR-18	CRS-18
1 1/4	12.700 0.5000	31.75 1.250	19.05 0.750	31.75 1.250	7.92 0.312	15.88 0.625	3.18 0.188	2.39 0.094	1/2-20	CR-20	CRS-20
1 3/8	12.700 0.5000	34.93 1.375	19.05 0.750	31.75 1.250	7.92 0.312	15.88 0.625	3.18 0.188	2.39 0.094	1/2-20	CR-22	CRS-22
1 1/2	15.875 0.6250	38.10 1.500	22.23 0.875	38.10 1.500	9.53 0.375	19.05 0.750	3.18 0.188	2.39 0.094	5/8-18	CR-24	CRS-24
1 5/8	15.875 0.6250	41.28 1.625	22.23 0.875	38.10 1.500	9.53 0.375	19.05 0.750	3.18 0.188	2.39 0.094	5/8-18	CR-26	CRS-26
1 3/4	19.050 0.7500	44.45 1.750	25.40 1.000	44.45 1.750	11.13 0.438	22.23 0.875	3.18 0.188	2.39 0.094	3/4-16	CR-28	CRS-28
1 7/8	19.050 0.7500	47.63 1.875	25.40 1.000	44.45 1.750	11.13 0.438	22.23 0.875	3.18 0.188	2.39 0.094	3/4-16	CR-30	CRS-30

⁽¹⁾ No lubrication hole in threaded end.

⁽²⁾ Oil hold (d₄) only.

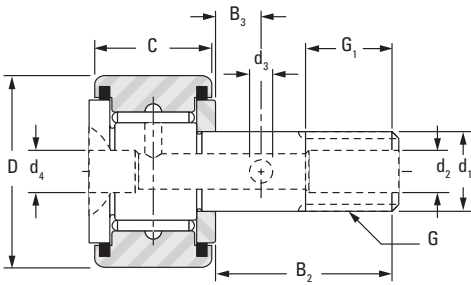

CR and CRS -12 to -64

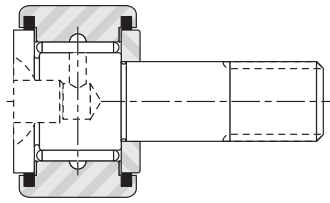

CR and CRS -8 to -10-1

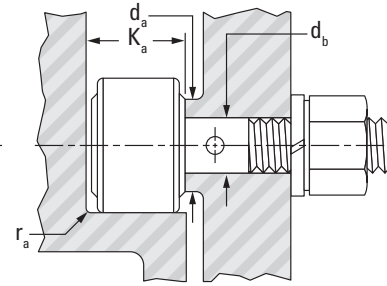

NOTE

Clamping torque is based on lubricated threads. If threads are dry, the torque values listed below may be doubled.

Load Ratings					Speed Rating Grease	Mounting Dimensions				Clamping Torque	Approx. Wt.
As a Bearing		As a Track Roller				db	ras max	Ka	da		
Dynamic	Static	Dynamic		Static		Bore Dia. for Stud +0.013 +0.0005 -0 -0.0000	Max.	Min.	Min.		
C	Co	Cw	Fr perm	FOr perm							
kN lbf.		kN lbf.			min ⁻¹	mm in.	mm in.	mm in.	mm in.	N-m lb-in.	kg lbs.
4.44 999	4.94 1110	3.01 677	1.04 233	2.49 560	7000	4.826 0.1900	0.25 0.010	10.41 0.41	7.52 0.296	1.69 15	0.010 0.022
4.98 1120	5.69 1280	3.38 759	1.21 272	2.90 652	7000	4.826 0.1900	0.25 0.010	11.18 0.44	7.52 0.296	1.69 15	0.010 0.023
6.05 1360	7.87 1770	4.37 982	2.26 508	5.43 1220	5500	6.350 0.2500	0.38 0.015	11.94 0.47	9.12 0.359	3.95 35	0.019 0.041
6.58 1480	8.76 1970	4.76 1070	2.53 569	6.09 1370	5500	6.350 0.2500	0.38 0.015	12.70 0.50	9.12 0.359	3.95 35	0.020 0.045
10.4 2330	15.2 3410	6.45 1450	2.88 647	6.89 1550	3900	9.525 0.3750	0.38 0.015	14.22 0.56	12.70 0.500	10.73 95	0.034 0.076
10.4 2330	15.2 3410	7.56 1700	4.80 1080	11.5 2590	3900	9.525 0.3750	0.38 0.015	14.22 0.56	12.70 0.500	10.73 95	0.044 0.097
13.3 2980	22.3 5010	8.94 2010	6.05 1360	14.5 3260	3000	11.113 0.4375	0.76 0.030	17.53 0.69	16.28 0.641	28.25 250	0.073 0.161
13.3 2980	22.3 5010	9.88 2220	8.67 1950	18.3 4120	3000	11.113 0.4375	0.76 0.030	17.53 0.69	16.28 0.641	28.25 250	0.089 0.197
23.3 5240	30.3 6810	16.1 3620	7.43 1670	17.8 40.10	2600	12.700 0.5000	0.76 0.030	20.57 0.81	19.43 0.765	39.54 350	0.137 0.301
23.3 5240	30.3 6810	17.7 3980	10.5 2350	25.1 5650	2600	12.700 0.5000	0.76 0.030	20.57 0.81	19.43 0.765	39.54 350	0.161 0.354
28.4 6380	40.8 9160	20.1 4520	10.8 2440	26.0 5850	2300	15.875 0.6250	0.76 0.030	23.88 0.94	22.63 0.891	73.44 650	0.239 0.528
28.4 6380	40.8 9160	21.5 4840	14.1 3170	33.8 7610	2300	15.875 0.6250	0.76 0.030	23.88 0.94	22.63 0.891	73.44 650	0.274 0.605
35.8 8040	56.9 12800	25.9 5830	17.7 3980	42.5 9560	1900	19.050 0.7500	1.02 0.040	26.92 1.06	26.59 1.047	141.23 1250	0.385 0.848
35.8 8040	56.9 12800	27.4 6150	22.0 4940	49.4 11100	1900	19.050 0.7500	1.02 0.040	26.92 1.06	26.59 1.047	141.23 1250	0.430 0.947

Continued on next page.



STUD-TYPE TRACK ROLLERS

CR, CRS SERIES – continued

INCH SERIES

- Screwdriver slot in head facilitates mounting.
- Non-separable, sealed unit with outer ring, full complement of needle rollers, stud seals, self-lubricating resin internal thrust washers and stud-fastened retaining washer.
- Seals help retain lubricant and exclude foreign matter (CRS Series).
- Re-lubrication via axially drilled hole through stud with cross-drilled holes in stud raceway and shank.
- Recessed axial hole accepts standard nominal inch drive-type grease lubrication fitting.
- Lubrication fitting plugs furnished to close off unused holes.
- Tolerance limits for outer diameters of stud, and outer ring refer to “single mean diameter.”
- A close fit between stud and hole required for mounting.
- Bore dimensions given below result in varying fit (0.025 mm tight to 0.013 mm loose [0.0010 in. tight to 0.0005 in. loose]).
- Retaining washer should be firmly backed up by flat housing shoulder (perpendicular to the stud axis).
- Shoulder diameter should be at least same size as minimum clamping diameter listed.
- May be mounted with two thin lock nuts, or nut and lock washer.

Outer Dia.	d ₁	D	C	B ₂	B ₃	G ₁	d ₂ and d ₄	d ₃	G	Track Roller Designation	
	+0.025 +0.0010 -0 -0.0000	+0 +0.000 -0.025 -0.001	+0 +0.000 -0.13 -0.005	(nom.)		Min.			UNF	Without Seals	With Seals and Internal Thrust Washers
in.	mm in.	mm in.	mm in.	mm in.	mm in.	mm in.	mm in.	mm in.	in.		
2	22.225 0.8750	50.80 2.000	31.75 1.250	50.80 2.000	12.70 0.500	25.40 1.000	4.77 0.188	4.77 0.188	7/8-14	CR-32	CRS-32
2 1/4	22.225 0.8750	57.15 2.250	31.75 1.250	50.80 2.000	12.70 0.500	25.40 1.000	4.77 0.188	4.77 0.188	7/8-14	CR-36	CRS-36
2 1/2	25.400 1.0000	63.50 2.500	38.10 1.500	57.15 2.250	14.27 0.562	28.58 1.125	4.77 0.188	4.77 0.188	1-14 ⁽¹⁾	CR-40	CRS-40
2 3/4	25.400 1.0000	69.85 2.750	38.10 1.500	57.15 2.250	14.27 0.562	28.58 1.125	4.77 0.188	4.77 0.188	1-14 ⁽¹⁾	CR-44	CRS-44
3	31.750 1.2500	76.20 3.000	44.45 1.750	63.50 2.500	15.88 0.625	31.75 1.250	6.35 0.250	6.35 0.250	1 1/4-12	CR-48	CRS-48
3 1/4	31.750 1.2500	82.55 3.250	44.45 1.750	63.50 2.500	15.88 0.625	31.75 1.250	6.35 0.250	6.35 0.250	1 1/4-12	CR-52	CRS-52
3 1/2	34.925 1.3750	88.90 3.500	50.80 2.000	69.85 2.750	17.48 0.688	34.93 1.375	6.35 0.250	6.35 0.250	1 3/8-12	CR-56	CRS-56
4	38.100 1.5000	101.60 4.000	57.15 2.250	88.90 3.500	19.05 0.750	38.10 1.500	6.35 0.250	6.35 0.250	1 1/2-12	CR-64	CRS-64

⁽¹⁾ UNS instead of UNF threads.

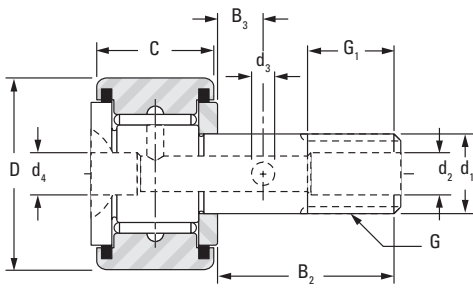

CR and CRS -12 to -64

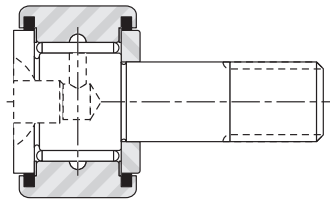

CR and CRS -8 to -10-1

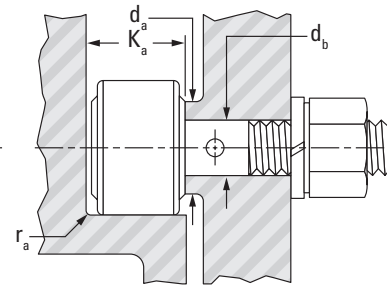

NOTE

Clamping torque is based on lubricated threads. If threads are dry, the torque values listed below may be doubled.

Load Ratings					Speed Rating Grease	Mounting Dimensions				Clamping Torque	Approx. Wt.
As a Bearing		As a Track Roller				db	ras max	Ka	da		
Dynamic	Static	Dynamic		Static		Bore Dia. for Stud +0.013 +0.0005 -0 -0.0000	Max.	Min.	Min.		
C	Co	Cw	FR perm	FOr perm							
kN lbf.		kN lbf.			min ⁻¹	mm in.	mm in.	mm in.	mm in.	N-m lb-in.	kg lbs.
43.5 9770	76.1 17100	31.8 7160	26.0 5850	60.5 13600	1700	22.225 0.8750	1.27 0.050	33.78 1.33	30.56 1.203	169.48 1500	0.621 1.37
43.5 9770	76.1 17100	34.6 7770	36.7 8250	71.2 16000	1700	22.225 0.8750	1.27 0.050	33.78 1.33	30.56 1.203	169.48 1500	0.757 1.67
58.7 13200	118 26600	44.5 10000	51.6 11600	101 22700	1400	25.400 1.0000	2.29 0.090	40.13 1.58	34.93 1.375	254.22 2250	1.134 2.50
58.7 13200	118 26600	47.2 10600	66.7 15000	113 25500	1400	25.400 1.0000	2.29 0.090	40.13 1.58	34.93 1.375	254.22 2250	1.329 2.93
74.7 16800	179 40200	51.6 11600	64.0 14400	127 28600	990	31.750 1.2500	2.29 0.090	46.48 1.83	44.45 1.750	389.80 3450	1.905 4.20
74.7 16800	179 40200	54.7 12300	80.1 18000	143 32100	990	31.750 1.2500	2.29 0.090	46.48 1.83	44.45 1.750	389.80 3450	2.182 4.81
111 24900	227 51000	82.3 18500	89.8 20200	187 42000	950	34.925 1.3750	2.29 0.090	52.83 2.08	48.82 1.922	474.54 4200	2.912 6.42
138 31100	321 72200	99.2 22300	121 27200	245 55000	780	38.100 1.5000	2.29 0.090	59.18 2.33	57.94 2.281	564.93 5000	4.291 9.46





STUD-TYPE TRACK ROLLERS

CRSB SERIES

INCH SERIES

B

- Non-separable, sealed unit with outer ring, full complement of needle rollers, stud seals, self-lubricating resin internal thrust washers and stud-fastened retaining washer.
- Seals help retain lubricant and exclude foreign matter (CRS Series).
- Hexagonal wrench socket in stud head for mounting.
- Re-lubrication via axially drilled hole through stud with cross-drilled holes in stud raceway and shank.
- Recessed axial hole accepts standard nominal inch drive-type grease lubrication fitting.
- Lubrication fitting plugs furnished to close off unused holes.
- Tolerance limits for outer diameters of stud and outer ring refer to "single mean diameter."
- A close fit between stud and hole required for mounting.
- Bore dimensions given below result in varying fit (0.025 mm tight to 0.013 mm loose [0.0010 in. tight to 0.0005 in. loose]).
- Retaining washer should be firmly backed up by flat housing shoulder (perpendicular to the stud axis).
- Shoulder diameter should be at least same size as minimum clamping diameter listed.
- May be mounted with two thin lock nuts, or nut and lock washer.

Outer Dia.	d ₁	D	C	B ₂	B ₃	G ₁	d ₄	d ₂	d ₃	G	Bearing Designation
	+0.025 +0.0010 -0 -0.0000	+0 +0.000 -0.025 -0.001	+0 +0.000 -0.13 -0.005	(nom.)		Min.				UNF	
in.	mm in.	mm in.	mm in.	mm in.	mm in.	mm in.	mm in.	mm in.	mm in.	mm in.	
1/2	4.826 0.1900	12.70 0.500	8.74 0.344	12.70 0.500	—	6.35 0.250	—	—	—	10-32	CRSB-8
1/2	4.826 0.1900	12.70 0.500	9.53 0.375	15.88 0.625	—	6.35 0.250	—	—	—	10-32	CRSB-8-1
5/8	6.350 0.2500	15.88 0.625	10.31 0.406	15.88 0.625	—	7.92 0.312	—	—	—	1/4-28	CRSB-10
5/8	6.350 0.2500	15.88 0.625	11.13 0.438	19.05 0.750	—	7.92 0.312	—	—	—	1/4-28	CRSB-10-1
3/4	9.525 0.3750	19.05 0.750	12.70 0.500	22.23 0.875	6.35 0.250	9.53 0.375	—	4.78 0.188	2.39 0.094	3/8-24	CRSB-12
7/8	9.525 0.3750	22.23 0.875	12.70 0.500	22.23 0.875	6.35 0.250	9.53 0.375	—	4.78 0.188	2.39 0.094	3/8-24	CRSB-14
1	11.113 0.4375	25.40 1.000	15.88 0.625	25.40 1.000	6.35 0.250	12.70 0.500	—	4.78 0.188	2.39 0.094	7/16-20	CRSB-16
1 1/8	11.113 0.4375	28.58 1.125	15.88 0.625	25.40 1.000	6.35 0.250	12.70 0.500	—	4.78 0.188	2.39 0.094	7/16-20	CRSB-18
1 1/4	12.700 0.5000	31.75 1.250	19.05 0.750	31.75 1.250	7.92 0.312	15.88 0.625	—	4.78 0.188	2.39 0.094	1/2-20	CRSB-20
1 3/8	12.700 0.5000	34.93 1.375	19.05 0.750	31.75 1.250	7.92 0.312	15.88 0.625	—	4.78 0.188	2.39 0.094	1/2-20	CRSB-22
1 1/2	15.875 0.6250	38.10 1.500	22.23 0.875	38.10 1.500	9.53 0.375	19.05 0.750	—	4.78 0.188	2.39 0.094	5/8-18	CRSB-24
1 5/8	15.875 0.6250	41.28 1.625	22.23 0.875	38.10 1.500	9.53 0.375	19.05 0.750	—	4.78 0.188	2.39 0.094	5/8-18	CRSB-26
1 3/4	19.050 0.7500	44.45 1.750	25.40 1.000	44.45 1.750	11.13 0.438	22.23 0.875	—	4.78 0.188	2.39 0.094	3/4-16	CRSB-28

⁽¹⁾ UNS instead of UNF threads.

Furnished with lubrication hole in head end of stud and lubrication fitting installed below bottom of hex wrench socket.

 For hexagonal wrench sizes, see page B-254.

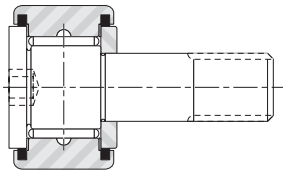

CRSB -8 to -10-1

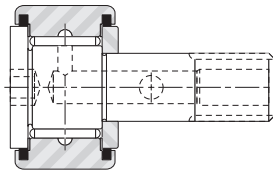

CRSB -24 to -44

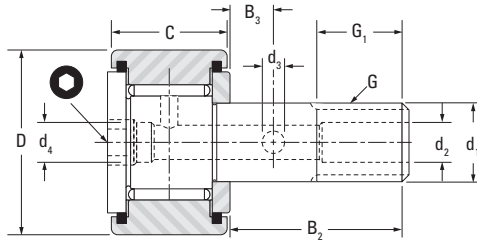

CRSB -12 to -22
CRSB -48 to -64

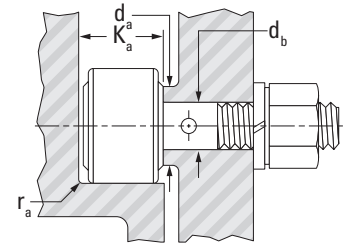

NOTE

Clamping torque is based on lubricated threads. If threads are dry, the torque values listed below may be doubled.

Load Ratings					Speed Rating Grease	Mounting Dimensions				Clamping Torque	Approx. Wt.
As a Bearing		As a Track Roller				db	ras max	Ka	da		
Dynamic	Static	Dynamic	Static			Bore Dia. for Stud	Max.	Min.	Min.		
C	Co	Cw	Fr perm	FOr perm		+0.013 +0.0005 -0 -0.0000					
kN lbf.		kN lbf.			min ⁻¹	mm in.	mm in.	mm in.	mm in.	N-m lb-in.	kg lbs.
4.44 999	4.94 1110	3.01 677	1.04 233	2.49 560	7000	4.826 0.1900	0.25 0.010	10.4 0.41	7.54 0.297	1.69 15	0.010 0.022
4.98 1120	5.69 1280	3.38 759	1.21 272	2.90 652	7000	4.826 0.1900	0.25 0.010	11.2 0.44	7.54 0.297	1.69 15	0.010 0.023
6.05 1360	7.87 1770	4.37 982	2.26 508	5.43 1220	5500	6.350 0.2500	0.38 0.015	11.9 0.47	9.12 0.359	3.95 35	0.019 0.041
6.58 1480	8.76 1970	4.76 1070	2.53 569	6.09 1370	5500	6.350 0.2500	0.38 0.015	12.7 0.50	9.12 0.359	3.95 35	0.020 0.045
10.4 2330	15.2 3410	6.45 1450	2.88 647	6.89 1550	3900	9.525 0.3750	0.38 0.015	14.2 0.56	12.70 0.500	10.73 95	0.034 0.076
10.4 2330	15.2 3410	7.56 1700	4.80 1080	11.5 2590	3900	9.525 0.3750	0.38 0.015	17.5 0.69	12.70 0.500	10.73 95	0.044 0.097
13.3 2980	22.3 5010	8.94 2010	6.05 1360	14.5 3260	3000	11.113 0.4375	0.76 0.030	17.5 0.69	16.28 0.641	28.25 250	0.073 0.161
13.3 2980	22.3 5010	9.88 2220	8.67 1950	18.3 4120	3000	11.113 0.4375	0.76 0.030	20.6 0.81	16.28 0.641	28.25 250	0.089 0.197
23.3 5240	30.3 6810	16.1 3620	7.43 1670	17.8 4010	2600	12.700 0.5000	0.76 0.030	20.6 0.81	19.43 0.765	39.54 350	0.137 0.301
23.30 5240	30.3 6810	17.7 3980	10.5 2350	25.1 5650	2600	12.700 0.5000	0.76 0.030	23.9 0.94	19.03 0.765	39.54 350	0.161 0.354
28.4 6380	40.8 9160	20.1 4520	10.9 2440	26.0 5850	2300	15.875 0.6250	0.76 0.030	23.9 0.94	22.63 0.891	73.44 650	0.354 0.528
28.4 6380	40.8 9160	21.5 4840	14.1 3170	33.8 7610	2300	15.875 0.6250	0.76 0.030	26.9 1.06	22.63 0.891	73.44 650	0.274 0.605
35.8 8040	56.94 12800	25.9 5830	17.7 3980	42.5 9560	1900	19.050 0.7500	1.02 0.040	26.9 1.06	26.59 1.047	141.23 1250	0.385 0.848

Continued on next page.



STUD-TYPE TRACK ROLLERS

CRSB SERIES – continued

INCH SERIES

B

- Non-separable, sealed unit with outer ring, full complement of needle rollers, stud seals, self-lubricating resin internal thrust washers and stud-fastened retaining washer.
- Seals help retain lubricant and exclude foreign matter (CRS Series).
- Hexagonal wrench socket in stud head for mounting.
- Re-lubrication via axially drilled hole through stud with cross-drilled holes in stud raceway and shank.
- Recessed axial hole accepts standard nominal inch drive-type grease lubrication fitting.
- Lubrication fitting plugs furnished to close off unused holes.
- Tolerance limits for outer diameters of stud and outer ring refer to “single mean diameter.”
- A close fit between stud and hole required for mounting.
- Bore dimensions given below result in varying fit (0.025 mm tight to 0.013 mm loose [0.0010 in. tight to 0.0005 in. loose]).
- Retaining washer should be firmly backed up by flat housing shoulder (perpendicular to the stud axis).
- Shoulder diameter should be at least same size as minimum clamping diameter listed.
- May be mounted with two thin lock nuts, or nut and lock washer.

Outer Dia.	d ₁	D	C	B ₂	B ₃	G ₁	d ₄	d ₂	d ₃	G	Bearing Designation
	+0.025 +0.0010 -0 -0.0000	+0 +0.000 -0.025 -0.001	+0 +0.000 -0.13 -0.005	(nom.)		Min.				UNF	
in.	mm in.	mm in.	mm in.	mm in.	mm in.	mm in.	mm in.	mm in.	mm in.	mm in.	
1 7/8	19.050 0.7500	47.63 1.875	25.40 1.000	44.45 1.750	11.13 0.438	22.23 0.875	—	4.78 0.188	2.39 0.094	3/4-16	CRSB-30
2	22.225 0.8750	50.80 2.000	31.75 1.250	50.80 2.000	12.70 0.500	25.40 1.000	—	4.78 0.188	3.18 0.125	7/8-14	CRSB-32
2 1/4	22.225 0.8750	57.15 2.250	31.75 1.250	50.80 2.000	12.70 0.500	25.40 1.000	—	4.78 0.188	3.18 0.125	7/8-14	CRSB-36
2 1/2	25.400 1.0000	63.50 2.500	38.10 1.500	57.15 2.250	14.27 0.562	28.58 1.125	—	4.78 0.188	3.18 0.125	1-14 ⁽¹⁾	CRSB-40
2 3/4	25.400 1.0000	69.85 2.750	38.10 1.500	57.15 2.250	14.27 0.562	28.58 1.125	—	4.78 0.188	3.18 0.125	1-14 ⁽¹⁾	CRSB-44
3	31.750 1.2500	76.20 3.000	44.45 1.750	63.50 2.500	15.88 0.625	31.75 1.250	6.35 0.250	6.35 0.250	3.18 0.125	1 1/4-12	CRSB-48
3 1/4	31.750 1.2500	82.55 3.250	44.45 1.750	63.50 2.500	15.88 0.625	31.75 1.250	6.35 0.250	6.35 0.250	3.18 0.125	1 1/4-12	CRSB-52
3 1/2	34.925 1.3750	88.90 3.500	50.80 2.000	69.85 2.750	17.48 0.688	34.93 1.375	6.35 0.250	6.35 0.250	3.18 0.125	1 3/8-12	CRSB-56
4	38.100 1.5000	101.60 4.000	57.15 2.250	88.90 3.500	19.05 0.750	38.10 1.500	6.35 0.250	6.35 0.250	3.18 0.125	1 1/2-12	CRSB-64
5	50.80 2.000	127.0 5.000	69.85 2.750	128.57 5.062	22.352 0.88	65.075 2.562	1/4 NPT	1/4 NPT	4.77 0.188	2-12	CRSB-80
6	63.50 2.500	152.4 6.000	82.55 3.250	152.4 6.000	25.40 1.00	76.2 3.000	1/4 NPT	1/4 NPT	4.77 0.188	2 1/2-12	CRSB-96

⁽¹⁾ UNS instead of UNF threads.

Furnished with lubrication hole in head end of stud and lubrication fitting installed below bottom of hex wrench socket.

 For hexagonal wrench sizes, see page B-254.

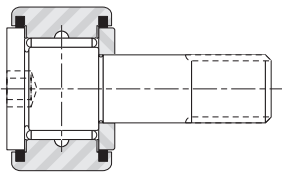

CRSB -8 to -10-1

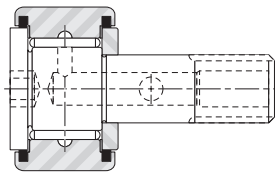

CRSB -24 to -44

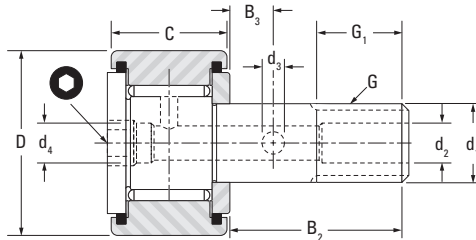

CRSB -12 to -22
CRSB -48 to -64

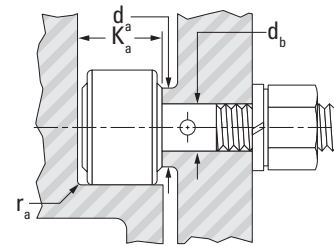

NOTE

Clamping torque is based on lubricated threads. If threads are dry, the torque values listed below may be doubled.

Load Ratings					Speed Rating Grease	Mounting Dimensions				Clamping Torque	Approx. Wt.
As a Bearing		As a Track Roller				db	ras max	Ka	da		
Dynamic	Static	Dynamic	Static			Bore Dia. for Stud	Max.	Min.	Min.		
C	Co	Cw	Fr perm	FOr perm		+0.013 +0.0005 -0 -0.0000					
kN lbf.		kN lbf.			min ⁻¹	mm in.	mm in.	mm in.	mm in.	N-m lb-in.	kg lbs.
35.8 8040	56.94 12800	27.4 6150	22.0 4940	49.4 11100	1900	19.050 0.7500	1.02 0.040	33.8 1.33	26.59 1.047	84.74 750	0.430 0.947
43.5 9770	76.06 17100	31.8 7160	26.0 5850	60.5 13600	1700	22.225 0.8750	1.27 0.050	33.8 1.33	30.56 1.203	101.69 900	0.621 1.370
43.5 9770	76.06 17100	34.6 7770	36.7 8250	71.2 16000	1700	22.225 0.8750	1.27 0.050	40.1 1.58	30.56 1.203	101.69 900	0.757 1.670
58.7 13200	118.32 26600	44.5 10000	51.6 11600	101 22700	1400	25.400 1.0000	2.29 0.090	40.1 1.58	34.93 1.375	152.53 1350	1.134 2.500
58.7 13200	118.32 26600	47.2 10600	66.7 15000	113 25500	1400	25.400 1.0000	2.29 0.090	44.5 1.75	34.93 1.375	152.53 1350	1.329 2.930
74.7 16800	178.82 40200	51.6 11600	64.0 14400	127 28600	990	31.750 1.2500	2.29 0.090	46.5 1.83	44.45 1.750	231.62 2050	1.905 4.200
74.7 16800	178.82 40200	54.7 12300	80.1 18000	143 32100	990	31.750 1.2500	2.29 0.090	46.5 1.83	44.45 1.750	231.62 2050	2.182 4.810
110.8 24900	226.86 51000	82.3 18500	89.8 20200	187 42000	950	34.925 1.3750	2.29 0.090	52.8 2.08	48.82 1.922	282.46 2500	2.912 6.420
138.3 31100	321.16 72200	99.2 22300	121 27200	245 55000	780	38.100 1.5000	2.29 0.090	59.2 2.33	57.94 2.281	338.95 3000	4.291 9.460
211.0 47.300	485.0 109000	152.0 34200	193.0 43400	385.0 86600	620	50.800 2.000	3.18 0.125	73.15 2.88	73.03 2.875	564.9 5000	8.89 19.60
285.0 64100	576.0 130000	209.0 47100	238.0 53600	473.0 106000	520	63500 2.500	3.18 0.125	85.85 3.38	85.73 3.375	564.9 5000	14.86 32.76



YOKE-TYPE TRACK ROLLERS

YCR, YCRS SERIES

INCH SERIES

- Non-separable unit with outer ring, a full complement of needle rollers, inner ring, self-lubricating resin internal thrust washers, and two retaining washers securely fastened to the inner ring.
- Seals in counterbores of outer ring seal against the retaining washers; retain lubricant and exclude foreign matter (YCRS Series).
- Dimensions shown are for unplated finished unit.

- Tolerance limits for outer diameters of stud and outer ring refer to "single mean diameter."
- The machine element with the holes in which the mounting bolt is supported must be sufficiently rigid to resist local crushing under the applied load and to resist bending which can cause uneven loading of the rollers.
- When the applied loads are high, the tight transition fit should be used in conjunction with a high strength shaft or bolt. When loads are moderate, the loose transition fit may be used with a high strength shaft or bolt. For light loads, the loose transition fit may be used with an unhardened shaft or bolt.

Outer Dia.	D	d		B	C	b	Track Roller Designation	
	+0 +0.000 -0.03 -0.001	Max.	Min.	+0.130 +0.0050 -0.250 -0.0100	+0 +0.000 -0.13 -0.005	(nom.)	Without Seals	With Seals and Internal Thrust Washers
in.	mm in.	mm in.	mm in.	mm in.	mm in.	mm in.		
3/4	19.05 0.75	6.355 0.2502	6.34 0.2496	14.288 0.5625	12.7 0.5	2.95 0.116	YCR-12	YCRS-12
7/8	22.23 0.875	6.355 0.2502	6.34 0.2496	14.288 0.5625	12.7 0.5	2.95 0.116	YCR-14	YCRS-14
1	25.4 1	7.943 0.3127	7.927 0.3121	17.463 0.6875	15.88 0.625	3.18 0.125	YCR-16	YCRS-16
1 1/8	28.58 1.125	7.943 0.3127	7.927 0.3121	17.463 0.6875	15.88 0.625	3.18 0.125	YCR-18	YCRS-18
1 1/4	31.75 1.25	9.53 0.3752	9.515 0.3746	20.638 0.8125	19.05 0.75	3.18 0.125	YCR-20	YCRS-20
1 3/8	34.93 1.375	9.53 0.3752	9.515 0.3746	20.638 0.8125	19.05 0.75	3.18 0.125	YCR-22	YCRS-22
1 1/2	38.1 1.5	11.118 0.4377	11.102 0.4371	23.813 0.9375	22.23 0.875	3.18 0.125	YCR-24	YCRS-24
1 5/8	41.28 1.625	11.118 0.4377	11.102 0.4371	23.813 0.9375	22.23 0.875	3.18 0.125	YCR-26	YCRS-26
1 3/4	44.45 1.75	12.705 0.5002	12.69 0.4996	26.988 1.0625	25.4 1	3.18 0.125	YCR-28	YCRS-28
1 7/8	47.63 1.875	12.705 0.5002	12.69 0.4996	26.988 1.0625	25.4 1	3.18 0.125	YCR-30	YCRS-30
2	50.8 2	15.88 0.6252	15.865 0.6246	33.338 1.3125	31.75 1.25	3.18 0.125	YCR-32	YCRS-32
2 1/4	57.15 2.25	15.88 0.6252	15.865 0.6246	33.338 1.3125	31.75 1.25	3.18 0.125	YCR-36	YCRS-36
2 1/2	63.5 2.5	19.055 0.7502	19.04 0.7496	39.688 1.5625	38.1 1.5	3.68 0.145	YCR-40	YCRS-40
2 3/4	69.85 2.75	19.055 0.7502	19.04 0.7496	39.688 1.5625	38.1 1.5	3.68 0.145	YCR-44	YCRS-44
3	76.2 3	25.403 1.0001	25.387 0.9995	46.038 1.8125	44.45 1.75	3.68 0.145	YCR-48	YCRS-48
3 1/4	82.55 3.25	25.403 1.0001	25.387 0.9995	46.038 1.8125	44.45 1.75	3.68 0.145	YCR-52	YCRS-52
3 1/2	88.9 3.5	28.578 1.1251	28.562 1.1245	52.388 2.0625	50.8 2	3.68 0.145	YCR-56	YCRS-56
4	101.6 4	31.753 1.2501	31.737 1.2495	58.738 2.3125	57.15 2.25	3.68 0.145	YCR-64	YCRS-64
5	127.0 5.00	44.453 1.7501	44.437 1.7495	73.025 2.875	69.85 2.750	8.64 0.341	YCR-80	YCRS-80
6	152.4 6.00	57.153 2.2501	57.137 2.2495	85.725 3.375	82.55 3.250	8.48 0.334	YCR-96	YCRS-96

- The unit should be clamped endwise between parallel faces perpendicular to the axis to prevent the retaining washers from coming off under load. If the unit cannot be clamped, a close axial fit in the yoke is required.

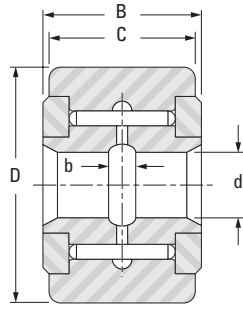

YCR

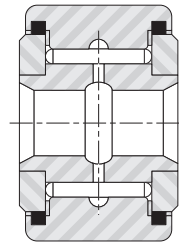

YCRS

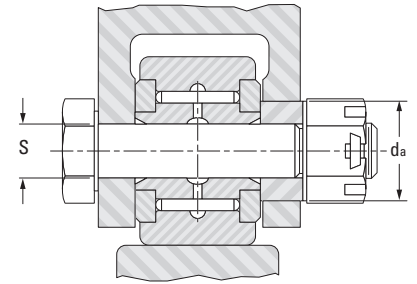

Load Ratings					Speed Rating Grease	Mounting Dimensions				d _a	Approx. Wt.
As a Bearing		As a Track Roller				Shaft Bolt Diameter (S)					
Dynamic	Static	Dynamic		Static		Loose Fit (f7)		Tight Fit (h6)			
C	C ₀	C _w	F _{r perm}	F _{0r perm}		Max.	Min.	Max.	Min.	mm in.	
kN lbf.		kN lbf.			min ⁻¹	mm in.	mm in.	mm in.	mm in.		
10.4 2330	15.2 3410	6.45 1450	2.88 647	6.89 1550	3900	6.342 0.2497	6.332 0.2493	6.363 0.2505	6.353 0.2501	12.700 0.500	0.027 0.06
10.4 2330	15.2 3410	7.56 1700	4.8 1080	11.5 2590	3900	6.342 0.2497	6.332 0.2493	6.363 0.2505	6.353 0.2501	12.700 0.500	0.036 0.08
13.3 2980	22.3 5010	8.94 2010	6.05 1360	14.5 3260	3000	7.93 0.3122	7.92 0.3118	7.95 0.313	7.94 0.3126	16.272 0.641	0.068 0.15
13.3 2980	22.3 5010	9.88 2220	8.67 1950	18.3 4120	3000	7.93 0.3122	7.92 0.3118	7.95 0.313	7.94 0.3126	16.272 0.641	0.077 0.17
23.3 5240	30.3 6810	16.1 3620	7.43 1670	17.8 4010	2600	9.517 0.3747	9.507 0.3743	9.538 0.3755	9.528 0.3751	19.447 0.766	0.109 0.24
23.3 5240	30.3 6810	17.7 3980	10.5 2350	25.1 5650	2600	9.517 0.3747	9.507 0.3743	9.538 0.3755	9.528 0.3751	19.447 0.766	0.136 0.3
28.4 6380	40.7 9160	20.1 4520	10.8 2440	26 5850	2300	11.105 0.4372	11.095 0.4368	11.125 0.438	11.115 0.4376	22.622 0.891	0.186 0.41
28.4 6380	40.7 9160	21.5 4840	14.1 3170	33.8 7610	2300	11.105 0.4372	11.095 0.4368	11.125 0.438	11.115 0.4376	22.622 0.891	0.227 0.5
35.8 8040	56.9 12800	25.9 5830	17.7 3980	42.5 9560	1900	12.692 0.4997	12.682 0.4993	12.718 0.5007	12.708 0.5003	26.591 1.047	0.29 0.64
35.8 8040	56.9 12800	27.4 6150	22 4940	49.4 11100	1900	12.692 0.4997	12.682 0.4993	12.718 0.5007	12.708 0.5003	26.591 1.047	0.363 0.8
43.5 9770	76.1 17100	31.8 7160	26 5850	60.5 13600	1700	15.867 0.6247	15.857 0.6243	15.893 0.6257	15.883 0.6253	30.559 1.203	0.476 1.05
43.5 9770	76.1 17100	34.6 7770	36.7 8250	71.2 16000	1700	15.867 0.6247	15.857 0.6243	15.893 0.6257	15.883 0.6253	30.559 1.203	0.599 1.32
58.7 13200	118 26600	44.5 10000	51.6 11600	100 22700	1400	19.042 0.7497	19.032 0.7493	19.068 0.7507	19.058 0.7503	33.338 1.313	0.816 1.8
58.7 13200	118 26600	47.2 10600	66.7 15000	113 25500	1400	19.042 0.7497	19.032 0.7493	19.068 0.7507	19.058 0.7503	33.338 1.313	1.021 2.25
74.7 16800	179 40200	51.6 11600	64 14400	127 28600	990	25.39 0.9996	25.377 0.9991	25.42 1.0008	25.408 1.0003	44.450 1.750	1.406 3.1
74.7 16800	179 40200	54.7 12300	80.1 18000	143 32100	990	25.39 0.9996	25.377 0.9991	25.42 1.0008	25.408 1.0003	44.450 1.750	1.642 3.62
111 24900	227 51000	82.3 18500	89.8 20200	187 42000	950	28.565 1.1246	28.552 1.1241	28.595 1.1258	28.583 1.1253	48.816 1.922	2.245 4.95
138 31100	321 72200	99.2 22300	121 27200	245 55000	780	31.74 1.2496	31.727 1.2491	31.77 1.2508	31.758 1.2503	57.944 2.281	3.198 7.05
211 47300	485 109000	152 34200	193 43400	385 86600	620	44.440 1.7496	44.427 1.7491	44.470 1.7508	44.458 1.7503	73.025 2.875	6.505 14.34
285 64100	576 130000	209 47100	238 53600	473 106000	520	57.140 2.2496	57.127 2.2491	57.170 2.2508	57.158 2.2503	85.725 3.375	9.144 20.16

