

- Compact PCB power module in 1.46" x 1.08" package
- Wide input voltage range 90-305 VAC
- Certified according to EN 60335-1 and IEC/EN/UL 62368-1
- I/O-Isolation 4'000 VAC
- Operating temperature range -40°C to +70°C
- No load input power <0.1W (acc. ErP directive)
- High efficiency up to 83%
- Internal EN 55032 class B filter
- Protection class II prepared
- 3 year product warranty



UL 62368-1 IEC 62368-1

The TMPW 5 is a 5 Watt AC/DC series with an extended input range of 90-305 VAC and is suitable for industrial and household/building technology applications and comes in a compact encapsulated plastic case. The 305 VAC (277 VAC ±10%) threshold is derived from a 480 VAC three-phase supply voltage often used in heavy industrial applications. Through the increased voltage level, the drawn current from the load is effectively reduced, which allows for an overall more compact and lightweight design approach. They offer an I/O-isolation voltage of 4000 VAC, a high temperature range of -40 to +70°C and are prepared for protection class II applications. Additionally, an internal EN 55032 class B filter saves valuable board space for an otherwise often mandatory external filter setup. An energy efficient design (<0.1 Watt standby power consumption) and safety approvals according to IEC/EN/UL 62368-1 and EN 60335-1 make this series suitable for a wide range of industrial and household/building technology applications.

### Models

Order Code	Output Power max.	Output Voltage nom.	Output Current max.	Efficiency typ.
TMPW 5-103	5 W	3.3 VDC	1'515 mA	73 %
TMPW 5-105		5 VDC	1'000 mA	77 %
TMPW 5-112		12 VDC	420 mA	81 %
TMPW 5-124		24 VDC	210 mA	83 %

### Input Specifications

Input Voltage	- AC Range - DC Range	90 - 305 VAC (Full Range) 100 - 250 VDC (264 VAC max. for Household Certification)
Input Frequency		47 - 63 Hz (designed to meet: 47 - 440 Hz)
Input Current	- Full Load & Vin = 230 VAC - Full Load & Vin = 115 VAC	90 mA max. 150 mA max.
Power Consumption	- At no load	100 mW max.
Input Inrush Current	- At 230 VAC - At 115 VAC	60 A max. 30 A max.
Recommended Input Fuse		1600 mA (slow blow) (The need of an external fuse has to be assessed in the final application.)

### Output Specifications

Voltage Set Accuracy		±2% max.
Regulation	- Input Variation (Vmin - Vmax)  - Load Variation (0 - 100%)	0.2% max. (3.3 & 5 Vout models) 0.1 % max. (other models) 1% max. (3.3 Vout model) 0.5 % max. (other models)
Ripple and Noise (20 MHz Bandwidth)	3.3 VDC model: 5 VDC model: 12 VDC model: 24 VDC model:	60 mVp-p max. (w/ 0.1 µF // 47 µF) 60 mVp-p max. (w/ 0.1 µF // 47 µF) 120 mVp-p max. (w/ 0.1 µF // 47 µF) 200 mVp-p max. (w/ 0.1 µF // 47 µF)
Capacitive Load	3.3 VDC model: 5 VDC model: 12 VDC model: 24 VDC model:	3'500 µF max. 2'500 µF max. 470 µF max. 150 µF max.
Minimum Load		Not required
Temperature Coefficient		±0.02 %/K max.
Hold-up Time	- At 230 VAC	15 ms min.
Short Circuit Protection		Continuous, Automatic recovery
Output Current Limitation		115% min. of Iout max.
Overvoltage Protection		105 - 145% of Vout nom. (By zener diode)

### Safety Specifications

Safety Standards	- IT / Multimedia Equipment  - Household  - Certification Documents	EN 62368-1 IEC 62368-1 UL 62368-1 EN 60335-1 IEC 60335-1 <a href="http://www.tracopower.com/overview/tmpw5">www.tracopower.com/overview/tmpw5</a>
Protection Class		Class II (Prepared): Reinforced Insulation
Pollution Degree		PD 2
Over Voltage Category		OVC II

### EMC Specifications

EMI Emissions	- Conducted Emissions - Radiated Emissions - Voltage Fluctuations & Flicker	EN 55032 class B (internal filter) EN 55032 class B (internal filter) EN 61000-3-3
---------------	---	--

All specifications valid at nominal voltage, full load and +25°C after warm-up time unless otherwise stated.

<b>EMS Immunity</b>		EN 55024 (IT Equipment) EN 55035 (Multimedia)
- Electrostatic Discharge	Air:	EN 61000-4-2, $\pm 8$ kV, perf. criteria A
- RF Electromagnetic Field	Contact:	EN 61000-4-2, $\pm 4$ kV, perf. criteria A EN 61000-4-3, 3 V/m, perf. criteria A EN 61000-4-4, $\pm 1$ kV, perf. criteria A
- EFT (Burst) / Surge	L to L:	EN 61000-4-5, $\pm 1$ kV, perf. criteria A EN 61000-4-6, 3 Vrms, perf. criteria A
- Conducted RF Disturbances	Continuous:	EN 61000-4-8, 1 A/m, perf. criteria A
- PF Magnetic Field	230 VAC / 50 Hz:	EN 61000-4-11 30%, 25 periods, perf. criteria A >95%, 250 periods, perf. criteria B
- Voltage Dips & Interruptions	115 VAC / 60 Hz:	EN 61000-4-11 30%, 25 periods, perf. criteria A >95%, 250 periods, perf. criteria B

## General Specifications

Relative Humidity		95% max. (non condensing)
Temperature Ranges	- Operating Temperature - Storage Temperature	-40°C to +70°C -40°C to +85°C
Power Derating	- High Temperature	2.5 %/K above 50°C (High Temperature) 2.0 %/K below -30°C (Low Temperature)
Cooling System		Natural convection (20 LFM)
Altitude During Operation		5'000 m max.
Insulation System		Reinforced Insulation
Working Voltage (rated)		314 VAC
Isolation Test Voltage	- Input to Output, 60 s	4'000 VAC
Leakage Current	- Touch Current	250 $\mu$ A max.
Reliability	- Calculated MTBF	450'000 h (MIL-HDBK-217F, ground benign)
Environment	- Vibration  - Mechanical Shock	IEC 60068-2-6 2 g, 3 axis, 60 min, 10-500 Hz, 10 min/cycle IEC 60068-2-27
Housing Material		Plastic resin (UL 94 V-0 rated)
Connection Type		THD (Through-Hole Device)
Weight		24 g
Environmental Compliance	- Reach - RoHS	<a href="http://www.tracopower.com/info/reach-declaration.pdf">www.tracopower.com/info/reach-declaration.pdf</a> <a href="http://www.tracopower.com/info/rohs-declaration.pdf">www.tracopower.com/info/rohs-declaration.pdf</a>

## Supporting Documents

Overview Link (for additional Documents)	<a href="http://www.tracopower.com/overview/tmpw5">www.tracopower.com/overview/tmpw5</a>
--	--

All specifications valid at nominal voltage, full load and +25°C after warm-up time unless otherwise stated.

**Outline Dimensions**

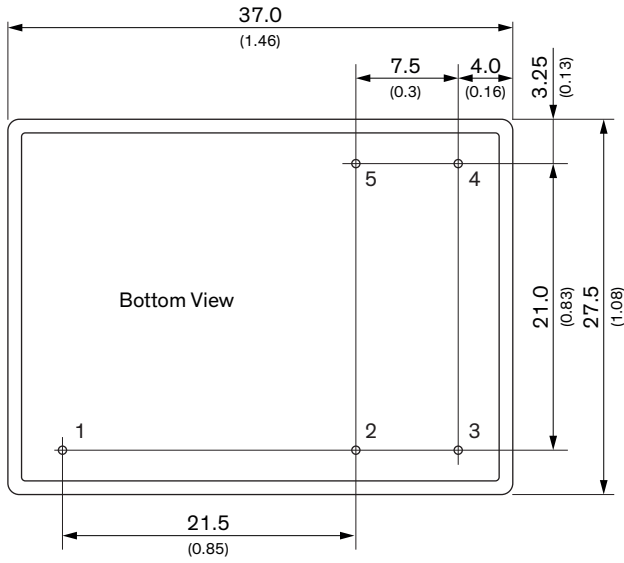

Pinout	
Pin	Single
1	NC
2	+Vout
3	-Vout
4	AC IN (L)
5	AC IN (N)

NC: Not connected

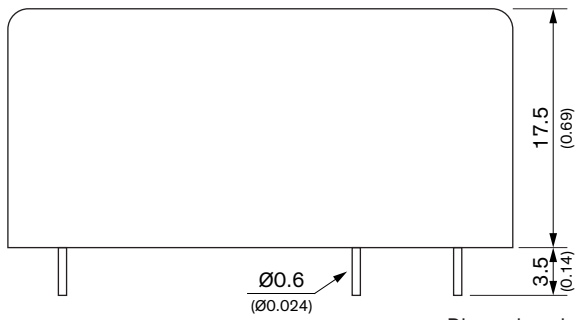

Dimensions in mm (inch)  
Tolerances: x.x ±0.5 (±0.02)