

# UGT513

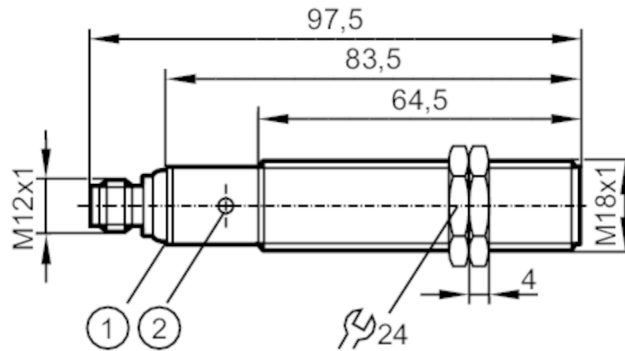

## Ultrasonic sensor

UGA02200E1KG/IO-LINK/US



- 1 LEDs
- 2 teach button



### Product characteristics

Electrical design	PNP
Output function	normally open / closed; (configurable + 1x current output)
Sensing range [mm]	200...2200; (Target: 200 x 200 mm)
Communication interface	IO-Link
Housing	Threaded type
Dimensions [mm]	M18 x 1 / L = 97.5

### Electrical data

Operating voltage [V]	10...30 DC; (cULus - Class 2 source required)
Current consumption [mA]	55
Protection class	III
Reverse polarity protection	yes
Power-on delay time [s]	< 0.3
Converter frequency [kHz]	200

### Inputs / outputs

Number of inputs and outputs	Number of digital outputs: 1; Number of analog outputs: 1
------------------------------	---

# UGT513



## Ultrasonic sensor

UGA02200E1KG/IO-LINK/US

Outputs	
Total number of outputs	2
Electrical design	PNP
Number of digital outputs	1
Output function	normally open / closed; (configurable + 1x current output)
Max. voltage drop switching output DC [V]	2.2
Permanent current rating of switching output DC [mA]	100
Switching frequency DC [Hz]	2
Number of analog outputs	1
Analog current output [mA]	4...20
Max. load [ $\Omega$ ]	500
Short-circuit protection	yes
Overload protection	yes
Resolution of analog output	< 3 mm
Monitoring range	
Sensing range [mm]	200...2200; (Target: 200 x 200 mm)
Blind zone [mm]	200
Angle of aperture cylindrical [ $^{\circ}$ ]	14; ( $\pm 2$ )
Max. deviation from the 90 $^{\circ}$ angle sensor/object [ $^{\circ}$ ]	$\pm 4$
Accuracy / deviations	
Temperature compensation	yes
Hysteresis [%]	< 2
Switch-point drift [%]	-2...2
Linearity error of analog output [%]	<3
Notes on the accuracy / deviation	The indicated values are reached after a warm-up time of min. 20 minutes
Repeatability	1 %
Reaction times	
Response time [ms]	< 400; (analog output)
Software / programming	
Parameter setting options	hysteresis / window; second switch point; Switch-on and switch-off delay; switch-on operations; Teach function; light-on/dark-on mode

# UGT513



## Ultrasonic sensor

UGA02200E1KG/IO-LINK/US

Interfaces		
Communication interface	IO-Link	
Transmission type	COM2 (38,4 kBaud)	
IO-Link revision	1.1	
SDCI standard	IEC 61131-9	
Profiles	Smart Sensor: Device Identification; Multi-channel, two setpoint switching sensor, type 0 Generic Profiled Sensor; Process Data Variable; Device Diagnosis; Teach Channel	
SIO mode	yes	
Required master port class	A	
Min. process cycle time [ms]	3.2	
IO-Link process data (cyclical)	Function	bit length
	process value	16
	device status	4
	binary switching information	2
IO-Link functions (acyclical)	application specific tag; operating hours counter	
Supported DeviceIDs	Type of operation	IO-Link device ID
	default	704 d / 00 02 C0 h
Note	For further information please see the IODD PDF file at "Downloads"	
Operating conditions		
Ambient temperature [°C]	-20...70	
Storage temperature [°C]	-30...80	
Protection	IP 67	
Tests / approvals		
EMC	EN 61000-4-2 ESD	4 kV CD / 8 kV AD
	EN 61000-4-3 HF radiated	3 V/m
	EN 61000-4-4 Burst	2 kV
	EN 61000-4-6 HF conducted	3 V
	EN 55011	class A
Vibration resistance	EN 60068-2-6 Fc	(10-55) Hz 1 mm amplitude, vibration duration 5 min., 30 min. per axis with resonance or 55 Hz
Shock resistance	EN 60068-2-27 Ea	30 g 11 ms half-sine; 3 shocks each in every direction of the 3 coordinate axes
MTTF [years]	142	
UL approval	Ta	-20...70 °C
	voltage supply	Class 2
	File number UL	E174191
Mechanical data		
Weight [g]	102	
Housing	Threaded type	
Dimensions [mm]	M18 x 1 / L = 97.5	
Thread designation	M18 x 1	
Material	stainless steel (1.4404 / 316L); PA; epoxy glass ceramics	
Tightening torque [Nm]	50	

# UGT513



## Ultrasonic sensor

UGA02200E1KG/IO-LINK/US

Displays / operating elements		
Display	Switching status	2 x LED, yellow
	echo	1 x LED, green
Teach function	yes	
Accessories		
Accessories (supplied)	lock nuts: 2, stainless steel	
Remarks		
Remarks	cULus - Class 2 source required	
Pack quantity	1 pcs.	

## Electrical connection

Connector: 1 x M12



## Connection

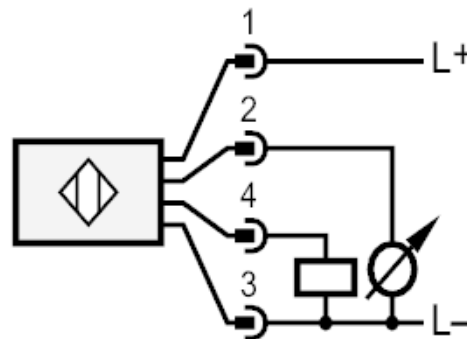

Pin 4 = IO-Link

### Diagrams and graphs

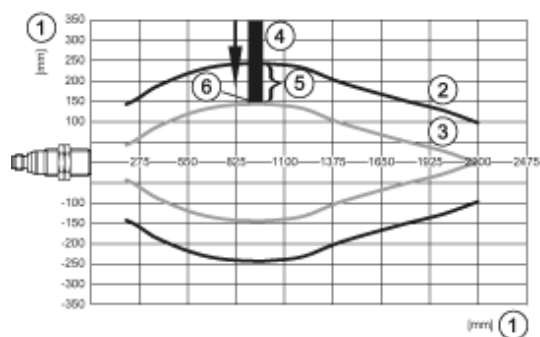
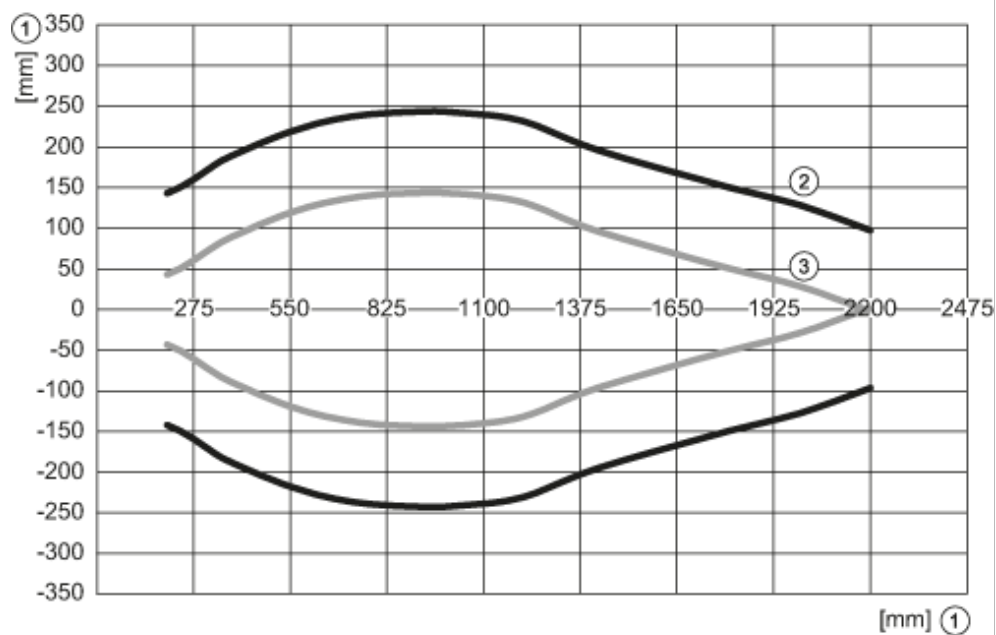

- 1: Distance
- 2: Monitoring range
- 3: switch-on/switch-off graph
- 4: Target 200 x 200 mm
- 5: 50 % of the target in the detection zone
- 6: Set point