

TIMKEN

The Timken Company
 4500 Mt Pleasant St. NW
 N. Canton, OH 44720
 Phone: (234) 262-3000
 E-Mail: CustomerCAD@timken.com • Web site: www.timken.com

Timken Part Number L68149 - L68111, Tapered Roller Bearings - TS (Tapered Single) Imperial

This is the most basic and most widely used type of tapered roller bearing. It consists of two main separable parts: the cone (inner ring) assembly and the cup (outer ring). It is typically mounted in opposing pairs on a shaft.

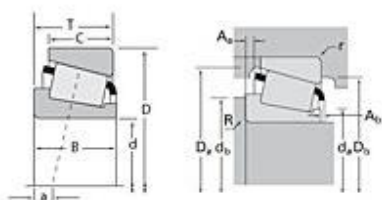

[Specifications](#) | [Dimensions](#) | [Abutment and Fillet Dimensions](#) | [Basic Load Ratings](#) | [Factors](#)

Specifications

Series	L68100
Cone Part Number	L68149
Cup Part Number	L68111
Design Units	Imperial
Bearing Weight	0.4 lb 0.200 Kg
Cage Type	Stamped Steel

Dimensions

d - Bore	1.3775 in 34.989 mm
D - Cup Outer Diameter	2.3612 in 59.974 mm

B - Cone Width	0.6600 in 16.764 mm
C - Cup Width	0.4700 in 11.938 mm
T - Bearing Width	0.6250 in 15.875 mm

Abutment and Fillet Dimensions

R - Cone Backface "To Clear" Radius¹	0.14 in 3.560 mm
r - Cup Backface "To Clear" Radius²	0.050 in 1.27 mm
da - Cone Frontface Backing Diameter	1.54 in 39.12 mm
db - Cone Backface Backing Diameter	1.79 in 45.47 mm
Da - Cup Frontface Backing Diameter	2.24 in 55.90 mm
Db - Cup Backface Backing Diameter	2.09 in 53.09 mm
Ab - Cage-Cone Frontface Clearance	0.06 in 1.5 mm
Aa - Cage-Cone Backface Clearance	0.01 in 0.3 mm
a - Effective Center Location³	-0.10 in -2.50 mm

Basic Load Ratings

C90 - Dynamic Radial Rating (90 million revolutions)⁴	2650 lbf 11800 N
C1 - Dynamic Radial Rating (1 million revolutions)⁵	10200 lbf 45500 N
C0 - Static Radial Rating	11000 lbf 48700 N
C_{a90} - Dynamic Thrust Rating (90 million revolutions)⁶	1890 lbf 8400 N

Factors

K - Factor⁷	1.4
e - ISO Factor⁸	0.42
Y - ISO Factor⁹	1.44
G1 - Heat Generation Factor (Roller-Raceway)	15.7
G2 - Heat Generation Factor (Rib-Roller End)	13.9
Cg - Geometry Factor	0.0657

¹ These maximum fillet radii will be cleared by the bearing corners.

² These maximum fillet radii will be cleared by the bearing corners.

³ Negative value indicates effective center inside cone backface.

⁴ Based on 90×10^6 revolutions L_{10} life, for The Timken Company life calculation method. C_{90} and C_{a90} are radial and thrust values.

⁵ Based on 1×10^6 revolutions L_{10} life, for the ISO life calculation method.

⁶ Based on 90×10^6 revolutions L_{10} life, for The Timken Company life calculation method. C_{90} and C_{a90} are radial and thrust values for a single-row, $C_{90(2)}$ is the two-row radial value.

⁷ These factors apply for both inch and metric calculations. Consult your Timken representative for instruction on use.

⁸ These factors apply for both inch and metric calculations. Consult your Timken representative for instruction on use.

⁹ These factors apply for both inch and metric calculations. Consult your Timken representative for instruction on use.

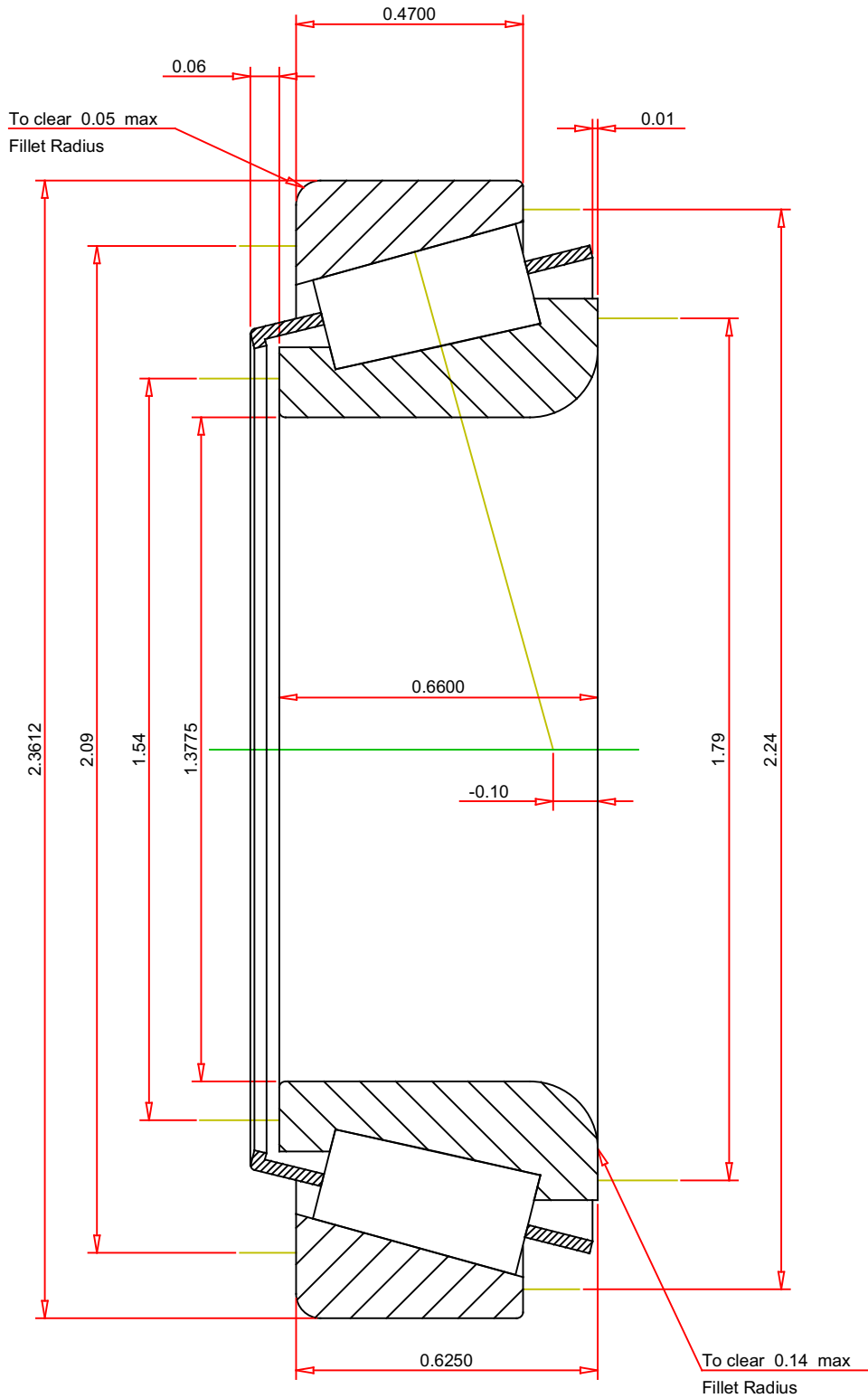

IMPERIAL UNITS

ISO Factor - e	0.42
ISO Factor - Y	1.44
Bearing Weight	0.4 lb
Number of Rollers Per Row	23
Effective Center Location	-0.1 inch

TIMKEN®

THE TIMKEN COMPANY
NORTH CANTON, OHIO USA

L68149 - L68111
TS BEARING ASSEMBLY

K Factor	1.4
Dynamic Radial Rating - C90	2650 lbf
Dynamic Thrust Rating - Ca90	1890 lbf
Static Radial Rating - C0	11000 lbf
Dynamic Radial Rating - C1	10200 lbf

Every reasonable effort has been made to ensure the accuracy of the information contained in this writing, but no liability is accepted for errors, omissions or for any other reason.

FOR DISCUSSION ONLY