

# McGILL® Inch Cam Follower Bearings

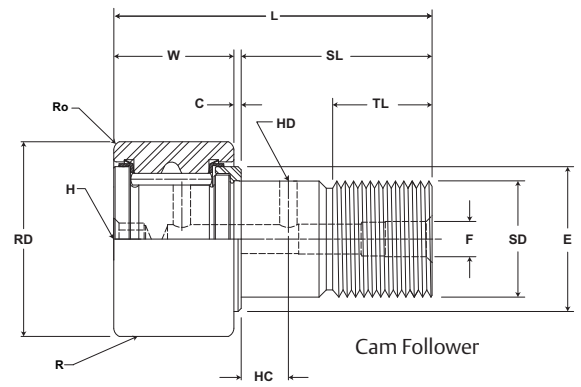

- Basic Construction Type:** Stud Type Crowned / Cylindrical Outside Diameter
- Rolling Elements:** Full Complement Needle Roller
- Bearing Material:** Bearing Quality Steel
- Seal Type:** LUBRI-DISC®
- Lubrication:** Lithium Soap Grease NLGI #2
- System Configuration:** Concentric / Eccentric / Heavy Stud
- Mounting Feature:** Slot / Hex Hole



## CF, CFE, CFH

Part No.		RD		W		SD		SL	C	TL	L	R	ECC	G	BD	Track Roller Dynamic Rating	Track Roller Static Rating	
W/O Seals	With LUBRI-DISC Seals	Roller Diameter		Roller Width		Stud Diameter		Stud Length	Endplate Extension	Min Thread Length	Length Overall	Crown Prefix CCF-XX	Eccentric Base Modifier CFE-XX					
		inch mm		inch mm		inch mm		inch mm		inch mm		inch mm		inch mm				
		Nom.	Tol.	Nom.	Tol.	Nom.	Tol.	(Ref)	(Ref)	(Ref)	(Ref)	Radius (Ref)	(Ref)	+0/-0.010	±.001			lb/N
CF 1/2	CF 1/2 S											Cylindrical				680 3,025	790 3,514	
CF 1/2 B	CF 1/2 SB	.500	+0/-0.001	.375	+0 / -0.005	.190	+0.01/-0	.63	.031	.25	1.03	7 178	N/A	N/A	N/A			
CCF 1/2	CCF 1/2 S	12.70	+0/-0.03	9.53	+0 / -0.13	4.83	+0.3/-0	15.9	.8	6.4	26.2							
CCF 1/2 B	CCF 1/2 SB																	
CFE 1/2	CFE 1/2 S												Cylindrical				680 3,025	790 3,514
CFE 1/2 B	CFE 1/2 SB	.500	+0/-0.001	.375	+0 / -0.005	.190	+0.01/-0	.63	.031	.25	1.03	7 178	.010	.375	.250			
CCFE 1/2	CCFE 1/2 S	12.70	+0/-0.03	9.53	+0 / -0.13	4.83	+0.3/-0	15.9	.8	6.4	26.2			9.53	6.35			
CCFE 1/2 B	CCFE 1/2 SB																	
CFH 1/2	CFH 1/2 S												Cylindrical				680 3,025	1,580 7,028
CFH 1/2 B	CFH 1/2 SB	.500	+0/-0.001	.375	+0 / -0.005	.190	+0.01/-0	.63	.031	.25	1.03	7 178	N/A	N/A	N/A			
CCFH 1/2	CCFH 1/2 S	12.70	+0/-0.03	9.53	+0 / -0.13	4.83	+0.3/-0	15.9	.8	6.4	26.2							
CCFH 1/2 B	CCFH 1/2 SB																	
CF 1/2 N	CF 1/2 N S												Cylindrical				620 2,758	720 3,203
CF 1/2 N B	CF 1/2 N SB	.500	+0/-0.001	.344	+0 / -0.005	.190	+0.01/-0	.50	.031	.25	.88	6 152	N/A	N/A	N/A			
CCF 1/2 N	CCF 1/2 N S	12.70	+0/-0.03	8.74	+0 / -0.13	4.83	+0.3/-0	12.7	.8	6.4	22.2							
CCF 1/2 N B	CCF 1/2 N SB																	
CFE 1/2 N	CFE 1/2 N S												Cylindrical				620 2,758	720 3,203
CFE 1/2 N B	CFE 1/2 N SB	.500	+0/-0.001	.344	+0 / -0.005	.190	+0.01/-0	.50	.031	.25	.88	6 152	.010	.250	.250			
CCFE 1/2 N	CCFE 1/2 N S	12.70	+0/-0.03	8.74	+0 / -0.13	4.83	+0.3/-0	12.7	.8	6.4	22.2			6.35	6.35			
CCFE 1/2 N B	CCFE 1/2 N SB																	
CF 9/16	CF 9/16 S												Cylindrical				680 3,025	790 3,514
CF 9/16 B	CF 9/16 SB	.5625	+0/-0.001	.375	+0 / -0.005	.190	+0.01/-0	.63	.031	.25	1.03	7 178	N/A	N/A	N/A			
CCF 9/16	CCF 9/16 S	14.29	+0/-0.03	9.53	+0 / -0.13	4.83	+0.3/-0	15.9	.8	6.4	26.2							
CCF 9/16 B	CCF 9/16 SB																	
CFE 9/16	CFE 9/16 S												Cylindrical				680 3,025	790 3,514
CFE 9/16 B	CFE 9/16 SB	.5625	+0/-0.001	.375	+0 / -0.005	.190	+0.01/-0	.63	.031	.25	1.03	7 178	.010	.375	.250			
CCFE 9/16	CCFE 9/16 S	14.29	+0/-0.03	9.53	+0 / -0.13	4.83	+0.3/-0	15.9	.8	6.4	26.2			9.53	6.35			
CCFE 9/16 B	CCFE 9/16 SB																	
CFH 9/16	CFH 9/16 S												Cylindrical				680 3,025	1,580 7,028
CFH 9/16 B	CFH 9/16 SB	.5625	+0/-0.001	.375	+0 / -0.005	.250	+0.01/-0	.63	.031	.25	1.03	7 178	N/A	N/A	N/A			
CCFH 9/16	CCFH 9/16 S	14.29	+0/-0.03	9.53	+0 / -0.13	6.35	+0.3/-0	15.9	.8	6.4	26.2							
CCFH 9/16 B	CCFH 9/16 SB																	

Metric dimensions for reference only.  
 Hex wrench size for "Broached" version is located in the wrench size chart on page B-156.  
 Not all parts are available from stock. Please contact customer service for availability (800) 626-2120.  
 For more information on bearing capabilities outside of our standard offering, please contact Application Engineering (800) 626-2093.

# Inch Cam Follower Bearings **MCGILL**

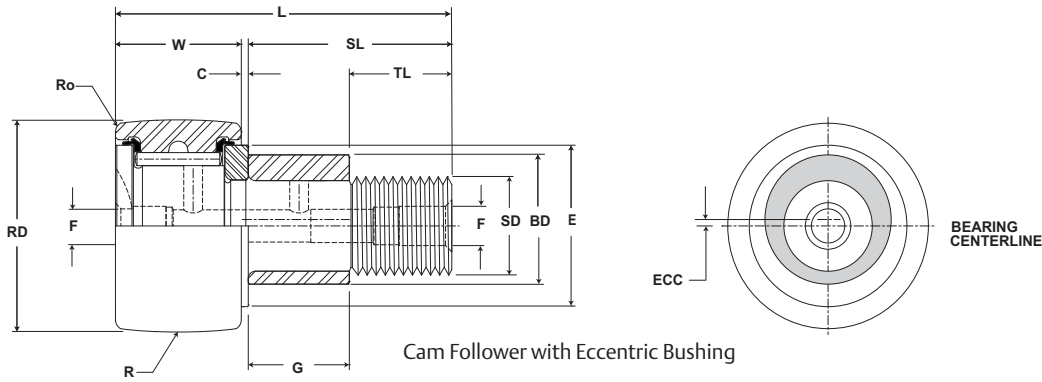

## CF, CFE, CFH

Part No.		HC	HD	F	E	Ro	HBD		Thread Type	Clamping Torque	Limiting Speed (Grease)	WT
W/O Seals	With LUBRI-DISC Seals	Hole Center	Radial Hole Diameter	Axial Hole Dia or Fitting	Min Boss Diameter	Outer Corner	Housing Bore Diameter					
		inch mm		inch mm		inch mm						
		(Ref)	(Ref)	(Ref)	(Ref)	Nom.	Tol.	in-lb Nm				
CF 1/2	CF 1/2 S	-	-	.125	.410	.016	.1903	+0.002/-0.003	10-32	15 2	11,500	.04 .02
CF 1/2 B	CF 1/2 SB			3.175	10.41	.40	4.834	+0.005/-0.008				
CCF 1/2	CCF 1/2 S						N/A					
CCF 1/2 B	CCF 1/2 SB											
CFE 1/2	CFE 1/2 S	-	-	.125	.410	.016	.253	+0.001/-0.001	10-32	15 2	11,500	.04 .02
CFE 1/2 B	CFE 1/2 SB			3.175	10.41	.40	6.42	+0.025/-0.025				
CCFE 1/2	CCFE 1/2 S						N/A					
CCFE 1/2 B	CCFE 1/2 SB											
CFH 1/2	CFH 1/2 S	-	-	.125	.410	.016	.2503	+0.002/-0.003	1/4-28	35 4	11,500	.04 .02
CFH 1/2 B	CFH 1/2 SB			3.175	10.41	.40	6.358	+0.005/-0.008				
CCFH 1/2	CCFH 1/2 S						N/A					
CCFH 1/2 B	CCFH 1/2 SB											
CF 1/2 N	CF 1/2 N S	-	-	.125	.410	.016	.1903	+0.002/-0.003	10-32	15 2	11,500	.04 .02
CF 1/2 N B	CF 1/2 N SB			3.175	10.41	.40	4.834	+0.005/-0.008				
CCF 1/2 N	CCF 1/2 N S						N/A					
CCF 1/2 N B	CCF 1/2 N SB											
CFE 1/2 N	CFE 1/2 N S	-	-	.125	.410	.016	.253	+0.001/-0.001	10-32	15 2	11,500	.04 .02
CFE 1/2 N B	CFE 1/2 N SB			3.175	10.41	.40	6.42	+0.025/-0.025				
CCFE 1/2 N	CCFE 1/2 N S						N/A					
CCFE 1/2 N B	CCFE 1/2 N SB											
CF 9/16	CF 9/16 S	-	-	.125	.410	.016	.1903	+0.002/-0.003	10-32	15 2	10,000	.04 .02
CF 9/16 B	CF 9/16 SB			3.175	10.41	.40	4.834	+0.005/-0.008				
CCF 9/16	CCF 9/16 S						N/A					
CCF 9/16 B	CCF 9/16 SB											
CFE 9/16	CFE 9/16 S	-	-	.125	.410	.016	.253	+0.001/-0.001	10-32	15 2	10,000	.04 .02
CFE 9/16 B	CFE 9/16 SB			3.175	10.41	.40	6.42	+0.025/-0.025				
CCFE 9/16	CCFE 9/16 S						N/A					
CCFE 9/16 B	CCFE 9/16 SB											
CFH 9/16	CFH 9/16 S	-	-	.125	.410	.016	.2503	+0.002/-0.003	1/4-28	35 4	10,000	.04 .02
CFH 9/16 B	CFH 9/16 SB			3.175	10.41	.40	6.358	+0.005/-0.008				
CCFH 9/16	CCFH 9/16 S						N/A					
CCFH 9/16 B	CCFH 9/16 SB											

For positive clamping, use housing thickness equal to G dimension = .010".  
Clamping torque is based on dry threads. If threads are lubricated, use half of value shown.  
Hex wrench size for "Broached" version is located in the wrench size chart on page B-156.