

McGILL® Inch Cam Follower Bearings

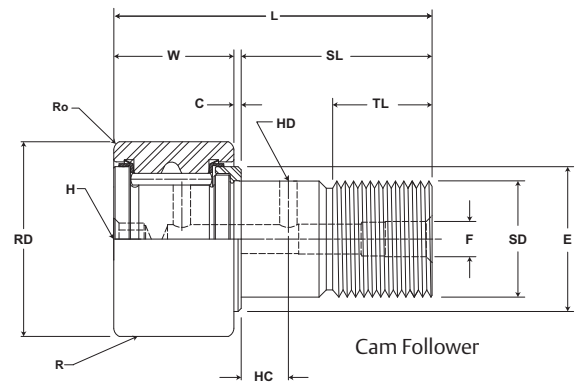

- Basic Construction Type:** Stud Type Crowned / Cylindrical Outside Diameter
- Rolling Elements:** Full Complement Needle Roller
- Bearing Material:** Bearing Quality Steel
- Seal Type:** LUBRI-DISC®
- Lubrication:** Lithium Soap Grease NLGI #2
- System Configuration:** Concentric / Eccentric / Heavy Stud
- Mounting Feature:** Slot / Hex Hole



CF, CFE, CFH

Part No.		RD		W		SD		SL	C	TL	L	R	ECC	G	BD	Track Roller Dynamic Rating	Track Roller Static Rating
W/O Seals	With LUBRI-DISC Seals	Roller Diameter		Roller Width		Stud Diameter		Stud Length	Endplate Extension	Min Thread Length	Length Overall	Crown Prefix CCF-XX	Eccentric Base Modifier CFE-XX				
		inch mm		inch mm		inch mm		inch mm	inch mm	inch mm	inch mm	inch mm	inch mm				
		Nom.	Tol.	Nom.	Tol.	Nom.	Tol.	(Ref)	(Ref)	(Ref)	(Ref)	Radius (Ref)	(Ref)	+0/-0.010	±.001		
CF 3/4	CF 3/4 S											Cylindrical				1,660 7,384	2,065 9,185
CF 3/4 B	CF 3/4 SB	.750	+0/-0.001	.500	+0 / -0.005	.375	+0.01/-0	.88	.031	.38	1.41	10 254	N/A	N/A	N/A		
CCF 3/4	CCF 3/4 S	19.05	+0/-0.03	12.70	+0 / -0.13	9.53	+0.03/-0	22.2	.8	9.5	35.7						
CCF 3/4 B	CCF 3/4 SB																
CFE 3/4	CFE 3/4 S											Cylindrical				1,660 7,384	2,065 9,185
CFE 3/4 B	CFE 3/4 SB	.750	+0/-0.001	.500	+0 / -0.005	.375	+0.01/-0	.88	.031	.38	1.41	10 254	.015	.500	.500		
CCFE 3/4	CCFE 3/4 S	19.05	+0/-0.03	12.70	+0 / -0.13	9.53	+0.03/-0	22.2	.8	9.5	35.7			12.70	12.70		
CCFE 3/4 B	CCFE 3/4 SB																
CFH 3/4	CFH 3/4 S											Cylindrical				1,660 7,384	4,130 18,370
CFH 3/4 B	CFH 3/4 SB	.750	+0/-0.001	.500	+0 / -0.005	.4375	+0.01/-0	.88	.031	.38	1.41	10 254	N/A	N/A	N/A		
CCFH 3/4	CCFH 3/4 S	19.05	+0/-0.03	12.70	+0 / -0.13	11.11	+0.03/-0	22.2	.8	9.5	35.7						
CCFH 3/4 B	CCFH 3/4 SB																
CF 7/8	CF 7/8 S											Cylindrical				1,660 7,384	2,065 9,185
CF 7/8 B	CF 7/8 SB	.875	+0/-0.001	.500	+0 / -0.005	.375	+0.01/-0	.88	.031	.38	1.41	10 254	N/A	N/A	N/A		
CCF 7/8	CCF 7/8 S	22.23	+0/-0.03	12.70	+0 / -0.13	9.53	+0.03/-0	22.2	.8	9.5	35.7						
CCF 7/8 B	CCF 7/8 SB																
CFE 7/8	CFE 7/8 S											Cylindrical				1,660 7,384	2,065 9,185
CFE 7/8 B	CFE 7/8 SB	.875	+0/-0.001	.500	+0 / -0.005	.375	+0.01/-0	.88	.031	.38	1.41	10 254	.015	.500	.500		
CCFE 7/8	CCFE 7/8 S	22.23	+0/-0.03	12.70	+0 / -0.13	9.53	+0.03/-0	22.2	.8	9.5	35.7			12.70	12.70		
CCFE 7/8 B	CCFE 7/8 SB																
CFH 7/8	CFH 7/8 S											Cylindrical				1,660 7,384	4,130 18,370
CFH 7/8 B	CFH 7/8 SB	.875	+0/-0.001	.500	+0 / -0.005	.4375	+0.01/-0	.88	.031	.38	1.41	10 254	N/A	N/A	N/A		
CCFH 7/8	CCFH 7/8 S	22.23	+0/-0.03	12.70	+0 / -0.13	11.11	+0.03/-0	22.2	.8	9.5	35.7						
CCFH 7/8 B	CCFH 7/8 SB																

Metric dimensions for reference only.
Hex wrench size for "Broached" version is located in the wrench size chart on page B-156.

Not all parts are available from stock. Please contact customer service for availability (800) 626-2120.
For more information on bearing capabilities outside of our standard offering, please contact Application Engineering (800) 626-2093.

Inch Cam Follower Bearings **McGILL**

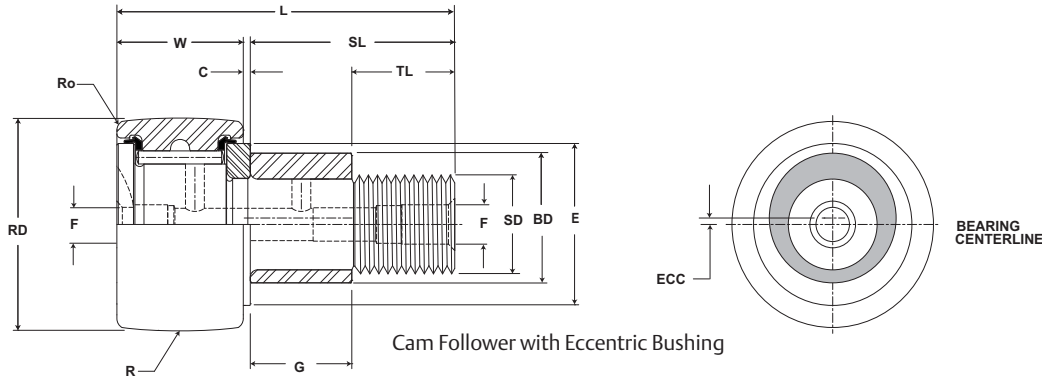

CF, CFE, CFH

Part No.		HC	HD	F	E	Ro	HBD		Thread Type	Clamping Torque	Limiting Speed (Grease)	WT
W/O Seals	With LUBRI-DISC Seals	Hole Center	Radial Hole Diameter	Axial Hole Dia or Fitting	Min Boss Diameter	Outer Corner	Housing Bore Diameter					
		inch		inch		inch						
		(Ref)	(Ref)	(Ref)	(Ref)	Nom.	Tol.	in-lb Nm				
CF 3/4	CF 3/4 S	.25 6	.0938 2	.1875 5	.609 15.48	.016 .40	.3753 9.533	+.0002/- .0003 +.0005/- .0008	3/8-24	95 11	6,400	.07 .03
CF 3/4 B	CF 3/4 SB					N/A						
CCF 3/4	CCF 3/4 S					N/A						
CCF 3/4 B	CCF 3/4 SB					N/A						
CFE 3/4	CFE 3/4 S	.25 6	.0938 2	.1875 5	.609 15.48	.016 .40	.503 12.77	+.001/- .001 +.025/- .025	7/16-20	250 28	6,400	.08 .04
CFE 3/4 B	CFE 3/4 SB					N/A						
CCFE 3/4	CCFE 3/4 S					N/A						
CCFE 3/4 B	CCFE 3/4 SB					N/A						
CFH 3/4	CFH 3/4 S	.25 6	.0938 2	.1875 5	.609 15.48	.016 .40	.4378 11.120	+.0002/- .0003 +.0005/- .0008	7/16-20	250 28	6,400	.08 .04
CFH 3/4 B	CFH 3/4 SB					N/A						
CCFH 3/4	CCFH 3/4 S					N/A						
CCFH 3/4 B	CCFH 3/4 SB					N/A						
CF 7/8	CF 7/8 S	.25 6	.0938 2	.1875 5	.609 15.48	.016 .40	.3753 9.533	+.0002/- .0003 +.0005/- .0008	3/8-24	95 11	5,400	.09 .04
CF 7/8 B	CF 7/8 SB					N/A						
CCF 7/8	CCF 7/8 S					N/A						
CCF 7/8 B	CCF 7/8 SB					N/A						
CFE 7/8	CFE 7/8 S	.25 6	.0938 2	.1875 5	.609 15.48	.016 .40	.503 12.77	+.001/- .001 +.025/- .025	7/16-20	250 28	5,400	.11 .05
CFE 7/8 B	CFE 7/8 SB					N/A						
CCFE 7/8	CCFE 7/8 S					N/A						
CCFE 7/8 B	CCFE 7/8 SB					N/A						
CFH 7/8	CFH 7/8 S	.25 6	.0938 2	.1875 5	.609 15.48	.016 .40	.4378 11.120	+.0002/- .0003 +.0005/- .0008	7/16-20	250 28	5,400	.11 .05
CFH 7/8 B	CFH 7/8 SB					N/A						
CCFH 7/8	CCFH 7/8 S					N/A						
CCFH 7/8 B	CCFH 7/8 SB					N/A						

For positive clamping, use housing thickness equal to G dimension = .010".
Clamping torque is based on dry threads. If threads are lubricated, use half of value shown.
Hex wrench size for "Broached" version is located in the wrench size chart on page B-156.