



SmartSolutions™ StarterKit Condition Monitoring



Validate with data. Provide Savings. Increase Value.

- Products with proven wireless communication and integrated cellular connectivity
- Configurable dashboards with default alarms assist in data-driven decisions and solutions
- Battery-powered devices for convenient installation
- Durable IP67-rated Sensors and Gateways

The turn-key, essential solution to kick-start predictive maintenance initiatives

The kit includes solutions for monitoring tank level, ambient temperature and humidity, the health of rotating machines and pressurized conditions. Banner's industrial-grade products automate maintenance checks inside your facility; Banner's Cloud Data Services platform enables customers to view graphs, create alerts, store and analyse data remotely.

Kit includes:



Tank Level Monitoring Sensor



Temp/Humidity Monitoring Sensor



Vibration Monitoring Sensor



Pressure Monitoring Sensor



Wireless Gateway



Prepaid Cellular and Banner Cloud Data Services

SmartSolutions™ StarterKit

Begin Your IIoT Journey with Banner

Kit Features:

- Connect a total of 10 sensor nodes for your specific application needs
- Preconfigured gateway provides time-saving Direct-to-Cloud functionality
- Wireless Gateway options for indoor and outdoor asset monitoring and communication
- Proven secure and reliable communications between sensors and the gateway (FHSS)
- 900 MHz ISM Radio for up to 50 times larger range than Bluetooth
- LCD user interface for sensor-binding process

Acquire insights with one Direct-to-Cloud Solution

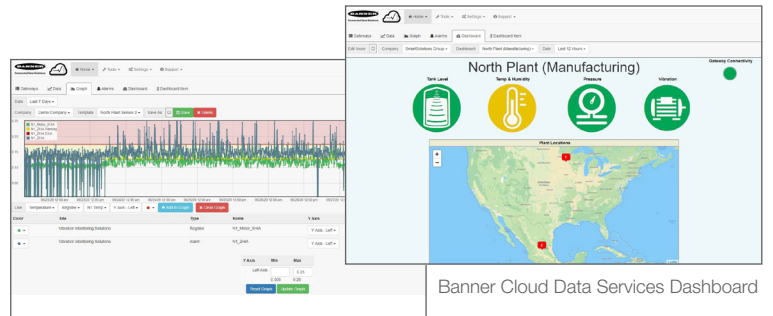

Banner Cloud Data Services Dashboard

The SmartSolutions™ StarterKit Series

Designed to enable owners of assets and processes to obtain actionable insights that will solve industrial challenges delivered in a robust and easily deployable solution. From high-grade sensing hardware and gateways, to trusted network connectivity and intuitive software, the SmartSolutions™ StarterKit Series provides the entire stack of technologies needed to evaluate the Industrial Internet of Things (IIoT) within an enterprise.

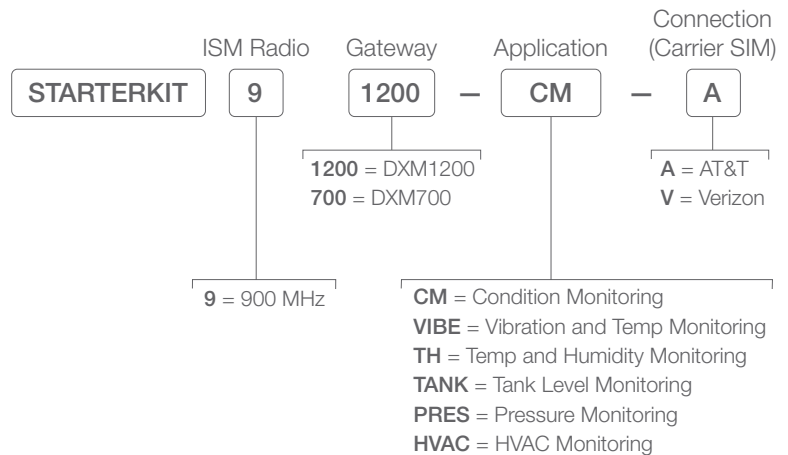

"Took no time to install, paid for itself and made me look good. Thanks!"

Matt M. - Sr Facility Manager

Designed to get up to speed quickly and scale with ease

The SmartSolutions™ StarterKit can deliver value in minutes, not hours or days. Add any additional industrial grade All-In-One Sensor Node to the StarterKit and adapt the system for the specific requirements of the application or facility.

Wireless Gateways



DXM1200 (Sealed)

DXM700

All-in-One Sensor Nodes



Vibration

Temp/Humidity

Tank Level

Pressure

Temp Probe

DXM1200 Wireless Gateway

Banner's Wireless Gateway is an industrial wireless device that facilitates Industrial Internet of Things (IIoT) applications. As a communications gateway, it offers seamless connectivity by hosting a robust ISM radio network for local wireless devices used to acquire and transmit data from assets within the industrial environment. The intuitive on-board display is used to bind the radios to the wireless network and an internal cellular modem provides a preconfigured connection to a 4G LTE network.

- ISM local radio network available in 900 MHz frequency band
- Equipped with IP67-rated housing for use in challenging environments
- DC Power Supply included within SmartSolutions™ StarterKit
- Embedded cellular connection with Verizon or AT&T carriers
- Internal radio and cellular antenna ensure reliable data transmission in all conditions
- Ethernet connection available



Models	Description
DXM1200-B1R1-SK-V	ISM 900 MHz Radio; preconfigured device detection with Verizon cellular module & SIM
DXM1200-B1R1-SK-A	ISM 900 MHz Radio; preconfigured device detection with AT&T cellular module & SIM

Specifications

Supply Voltage	12 to 30 V DC (use only with a suitable Class 2 power supply (UL) or a Limited Power Source (LPS) (CE) power supply)
Construction	Polycarbonate
Environmental Rating	IEC IP67
Operating Conditions	-20 to +60 °C (-4 to +140 °F)
Security Protocol	TLS, SSL, HTTPS
Push to Cloud Rate	Once every 10 minutes
900 MHz Compliance	FCC ID UE3RM1809: FCC Part 15, Subpart C, 15.247 IC: 7044A-RM1809 IFT: RCPBARM13-2283
Certifications	

Support Literature

216539	Sure Cross® DXM1200-Bx Wireless Controller Instruction Manual
196719	Sure Cross® DXM1200-Bx Wireless Controller Datasheet

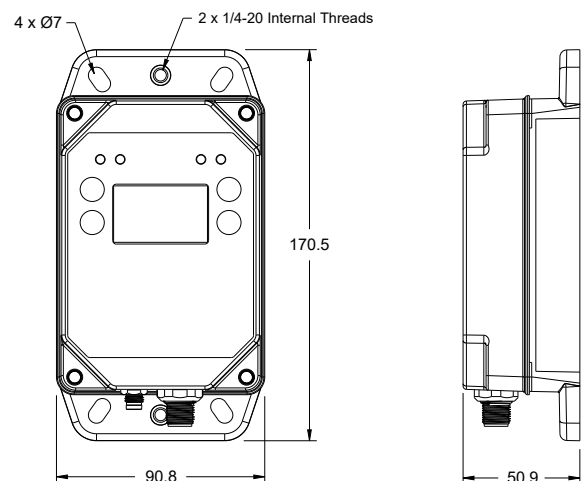

Q45UA All-in-One Ultrasonic Sensor Node

Q45UA devices combine an ISM radio, sensor, and battery power supply into one easy-to-deploy Sensor Node. The Q45UA is a compact industrial-grade device specially designed to monitor the level of fluid or dry assets in tanks, totes, and containers.

- Prevents tank overfills and pump cavitation by providing level status and alarming capabilities
- Easy-to-use/rugged device can be mounted permanently to equipment or temporarily threaded into bung holes of supply tanks
- 2+ years of battery life with simple installation
- With no tethered wires the sensor can move with the container or be easily unthreaded and mounted to a new container
- Designed for both retrofitting machines or new installations



Models*	Radio Frequency	Ultrasonic input Range and Frequency	Inputs
DX80N9Q45UAA	900 MHz ISM Band	Range: 100 mm to 1 m (3.94 in to 39.4 in) Frequency: 240 kHz	Inputs: One Ultrasonic Input, One Thermistor Input

* Additional sensors available to add to the StarterKit Series. See last page for more information.

Specifications

Performance	UAA Models Sensing range: 100 mm to 1 m (3.94 to 39.4 in) Ultrasonic Frequency: 240 kHz Temperature effect: 0.02% of distance/°C Resolution: 1 mm
Construction	Molded reinforced thermoplastic polyester housing, oring-sealed transparent Lexan® cover, molded acrylic lenses, and stainless steel hardware. Designed to withstand 1200 psi washdown.
Environmental Rating	NEMA 6P, IEC IP67
Operating Conditions	-40 to +70 °C (-40 to +158 °F)
900 MHz Compliance	FCC ID UE3RM1809: FCC Part 15, Subpart C, 15.247 IC: 7044A-RM1809 IFT: RCPBARM13-2283
Certifications	

Support Literature

207212	Sure Cross® Wireless Q45UA All-in-One Ultrasonic Node Datasheet
--------	---

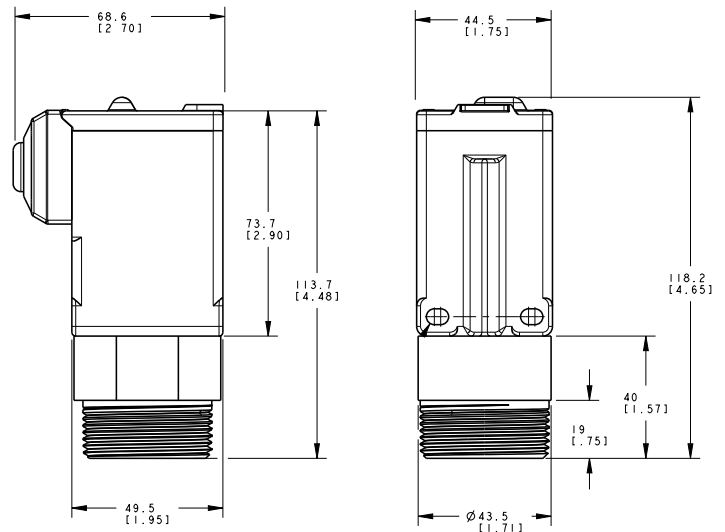

Q45THA All-in-One Temperature and Humidity Sensor Node

The Q45THA All-in-One Sensor Node combines a temperature and humidity probe with reliable, field-proven, wireless architecture into one package that eliminates the need for ordering multiple components and reducing the physical size of the device. This Sensor Node provides the temperature and humidity data needed to keep track of manufacturing and process tolerances for food processing and bulk storage.



- Designed to measure manufacturing and control processes with multiple mounting options (bracket included)
- 3+ years of battery life with simple installation
- Temperature sensing range of -40 to 85 °C (-40 to 185 °F)
- Humidity sensing range of 0% to 100% relative humidity (RH)
- Temperature accuracy of ± 0.4 °C and humidity accuracy of $\pm 2\%$



Models*	Radio Frequency	Inputs
DX80N9Q45THA	900 MHz ISM Band	Temperature and relative humidity (%)

* Additional sensors available to add to the StarterKit Series. See last page for more information.

Specifications

Temperature	Measuring Range: -40 to +85 °C (-40 to +185 °F) Resolution: 0.1 °C Accuracy: -40 to 0 °C: ± 0.6 °C 0 to 60 °C: ± 0.4 °C +60 to +85°C: ± 1.2 °C
Humidity	Measuring Range: 0 to 100% relative humidity (RH) Resolution: 0.1% relative humidity Accuracy: $\pm 2\%$ at 25 °C $\pm 3\%$ at 0 to 70 °C and 10–90% RH $\pm 7\%$ at 0 to 70 °C and 0–10 % or 90–100 % RH
Construction	Molded reinforced thermoplastic polyester housing, oring-sealed transparent Lexan® cover, molded acrylic lenses, and stainless steel hardware
Environmental Rating	NEMA 6P, IEC IP67
Operating Conditions	-40 to +70 °C (-40 to +158 °F)
900 MHz Compliance	FCC ID UE3RM1809: FCC Part 15, Subpart C, 15.247 IC: 7044A-RM1809 IFT: RCPBARM13-2283
Certifications	 

Support Literature

216537	Sure Cross® Wireless Q45THA All-in-One Temperature and Humidity Sensor Node (900 MHz models)
---------------	--

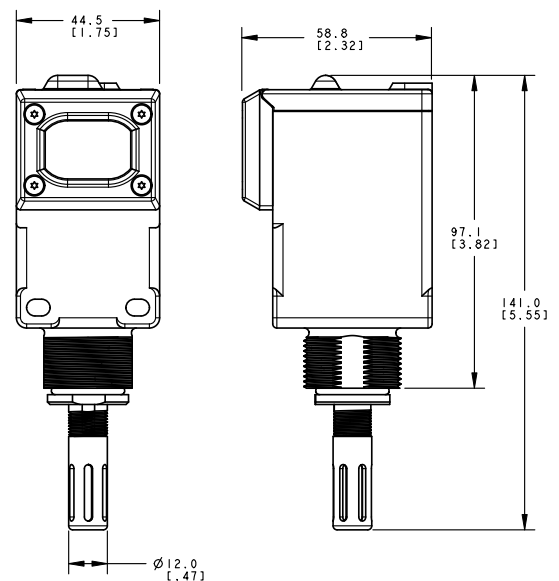

Q45PS All-in-One Pressure Sensor Node

The Q45PS All-in-One Pressure Sensor combines a media isolated pressure sensor with reliable, field-proven, wireless architecture into one package that eliminates the need for ordering multiple components and reducing the physical size of the device. This solution monitors pressurized systems in remote and hard-to-access locations where implementing a wired solution would be difficult, impractical, or not cost-effective.



- For use in pneumatic and hydraulic systems, HVAC systems, cooling systems, compressors, and chiller applications
- 1.5+ years of battery life with simple installation
- Achieves pressure accuracy of $\pm 1.4\%$ full scale
- 1/4-inch NPT thread connection port for use in most applications



Models*	Radio Frequency	Pressure Range	Inputs
DX80N9Q45PS150G	900 MHz ISM Band	0 to 150 PSIG (10 bar)	Q45 with integrated gauge pressure sensor

* Additional sensors available to add to the StarterKit Series. See last page for more information.

Specifications

Performance	Range: 0 to 150 PSIG Proof Pressure: 2x FS Burst Pressure: 3x FS Fatigue Life: > 4 million cycles Output: 0-5 V DC Accuracy: $\pm 1.4\%$ FS Pressure Sensor Mechanical Pressure Fitting: 1/4"-18 NPT Rating: IP65 Housing: 304 Stainless Steel Wetted Material: 316 Stainless Steel
Construction	Molded reinforced thermoplastic polyester housing, oring-sealed transparent Lexan® cover, molded acrylic lenses, and stainless steel hardware. Designed to withstand 1200 psi washdown.
Environmental Rating	NEMA 6P, IEC IP67
Operating Conditions	-40 to +70 °C (-40 to +158 °F)
Default Sensing Interval	5 Minutes
900 MHz Compliance	FCC ID UE3RM1809: FCC Part 15, Subpart C, 15.247 IC: 7044A-RM1809 IFT: RCPBARM13-2283
Certifications	 

Support Literature

216536	Sure Cross® Wireless Q45PS All-in-One Pressure Sensor Datasheet
---------------	---

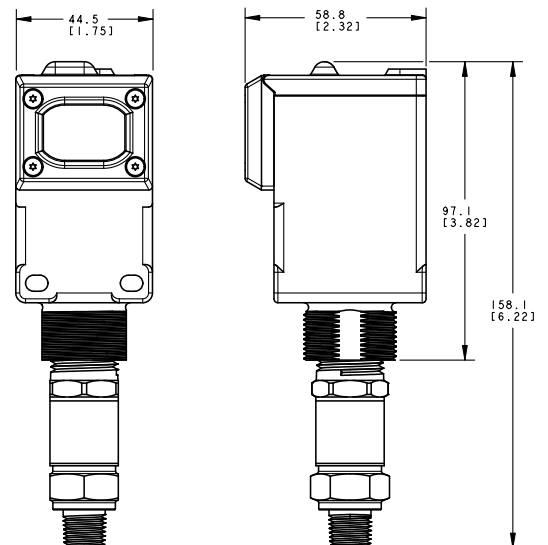

Q45VA All-in-One Vibration Sensor Node

Q45VA devices combine an ISM radio, sensor, and battery power supply into one easy-to-deploy Sensor Node. The Q45VA is a compact industrial-grade device specially designed to analyze vibration and temperature data that can be used to identify and predict failures for rotating machinery.

- Delivers pre-processed high accuracy vibration values for monitoring rotating equipment such as motors, pumps, rotary compressors, exhaust or HVAC fan motors, and spindles.
- Achieves vibration accuracy of $\pm 10\%$ RMS velocity (in/sec)
- 2+ years of battery life with simple installation (Two mounting bracket options included)
- Detects vibration characteristics on two axis (radial and axial) and two bands of RMS velocity and High Frequency Acceleration



Models*	Radio Frequency	Inputs & Outputs
DX80N9Q45VA-BK	900 MHz ISM Band	Vibration and temperature detection

(BWA-BK-009 and BWA-BK-010 (magnetic) Mounting Brackets included)

* Additional sensors available to add to the StarterKit Series. See last page for more information.

Specifications

Construction	Molded reinforced thermoplastic polyester housing, oring-sealed transparent Lexan® cover, molded acrylic lenses, and stainless steel hardware. Designed to withstand 1200 psi washdown.
Environmental Rating	NEMA 6P, IEC IP67
Operating Conditions	Ambient temperature: -40 to $+70$ °C (-40 to $+158$ °F) Contact temperature: -40 to $+105$ °C (-40 to $+221$ °F)
Vibration Sensor	Measuring Range: 0 to 46 mm/sec or 0 to 1.8 in/sec RMS Frequency Range: 10 Hz to 4 kHz Accuracy: $\pm 10\%$ at 25 °C Sampling Frequency: 20 kHz (default) Record Length: 8192 points (default) Sample Duration: 0.4 s (default)
Temperature Sensor	Measuring Range: -40 to $+105$ °C (-40 to $+221$ °F)
Default Sensing Interval	5 minutes
900 MHz Compliance	FCC ID UE3RM1809: FCC Part 15, Subpart C, 15.247 IC: 7044A-RM1809 IFT: RCPBARM13-2283
Certifications	

Support Literature

205704	Sure Cross® Wireless Q45VA All-in-One Vibration and Temperature Node Data sheet
208986	Q45VA Sensor Mounting Options Quick Start Guide

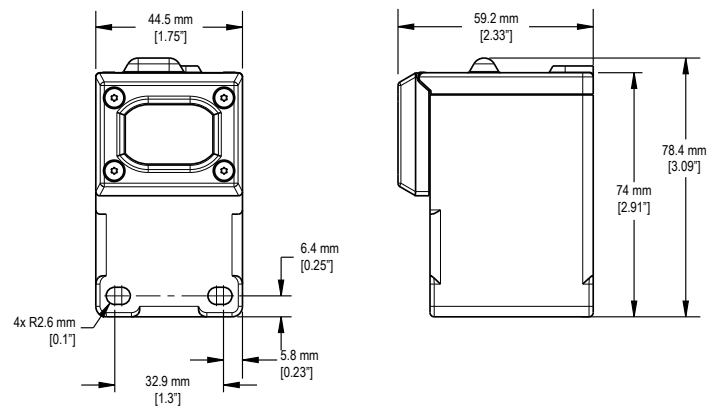

Additional Sensor Nodes to Expand your StarterKit

Add additional devices for up to 10 sensor nodes per gateway that monitor tank level, ambient temperature and humidity, the health of rotating machines and pressurized conditions.

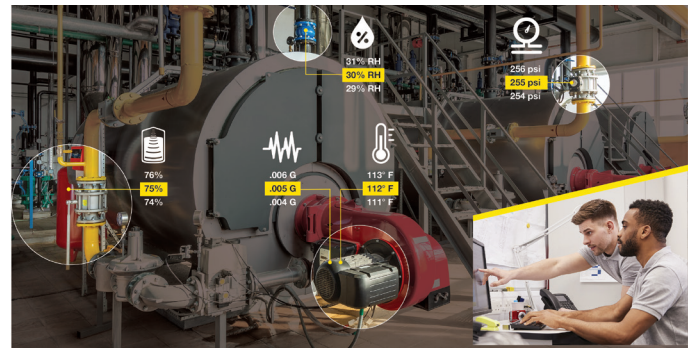

Banner Engineering has hundreds of sensor solutions to meet your needs. Please visit BannerEngineering.com to discover the right solution for your specialized applications.

All-in-One Ultrasonic Sensor Node



Models	Radio Frequency	Ultrasonic input Range and Frequency	Inputs
DX80N9Q45UAA	900 MHz ISM Band	Range: 100 mm to 1 m (3.94 in to 39.4 in) Frequency: 240 kHz	Inputs: One Ultrasonic Input, One Thermistor Input
DX80N9Q45UAC	900 MHz ISM Band	Range: 300 mm to 3 m (11.8 in to 118 in) Frequency: 114 kHz	

All-in-One Pressure Sensor Node



Models	Radio Frequency	Pressure Range	Inputs
DX80N9Q45PS50G	900 MHz ISM Band	0 to 50 PSIG (3.4 bar)	Integrated pressure sensor
DX80N9Q45PS150G	900 MHz ISM Band	0 to 150 PSIG (10 bar)	
DX80N9Q45PS500S	900 MHz ISM Band	0 to 500 PSIG (34 bar)	

All-in-One Temperature and Humidity Sensor Node



Models	Radio Frequency	Measurement Range	Inputs
DX80N9Q45THA	900 MHz ISM Band	-40 to +85 °C (-40 to +185 °F) 0 to 100% Relative Humidity	Temperature and relative humidity (%)

All-in-One Temperature Probe Sensor Node



Models	Radio Frequency	Measurement Range	Inputs
DX80N9Q45TA	900 MHz ISM Band	-20 to +105 °C (-4 to +221 °F)	Temperature

All-in-One Vibration Sensor Node



Models	Radio Frequency	Inputs & Outputs
DX80N9Q45VA-BK	900 MHz ISM Band	Vibration and temperature detection

(BWA-BK-009 and BWA-BK-010 (magnetic) Mounting Brackets included)

Wireless Node and Compact Vibration Sensor (must be purchased together)



Models	Communication	Radio Frequency	Inputs & Outputs
DX80N9Q45VTP	ISM Radio Band	900 MHz	Vibration and temperature detection
QM30VT1	1-Wire Serial	-	