

# PRODUCT INFORMATION PACKET



Model No: M1120058.00  
Catalog No: M1120058.00  
0.17 HP Sub-Fractional Motor, 3500 RPM, 90 V, 31 Frame, TENV  
Sub-Fractional Motors



Regal and Leeson are trademarks of Regal Beloit Corporation or one of its affiliated companies.  
©2020 Regal Beloit Corporation, All Rights Reserved. MC017097E





**Nameplate Specifications**

Output HP	0.17 Hp	Output KW	0.13 kW
Voltage	90 V	Current	1.9 A
Speed	3500 rpm	Service Factor	1
Efficiency	73.3 %	Duty	Continuous
Insulation Class	H	Frame	31
Enclosure	Totally Enclosed Non Ventilated	Thermal Protection	No
Ambient Temperature	40 °C	Drive End Bearing Size	6201-13
Opp Drive End Bearing Size	6201-13	UL	Recognized
CSA	Y	CE	Y

**Technical Specifications**

Rotation	Reversible	Mounting	Round
Overall Length	8.45 in	Frame Length	4.50 in
Shaft Diameter	0.500 in	Shaft Extension	1.5 in
Connection Drawing	M1005321	Outline Drawing	M1031034-M1120058

This is an uncontrolled document once printed or downloaded and is subject to change without notice. Date Created:30/12/2020

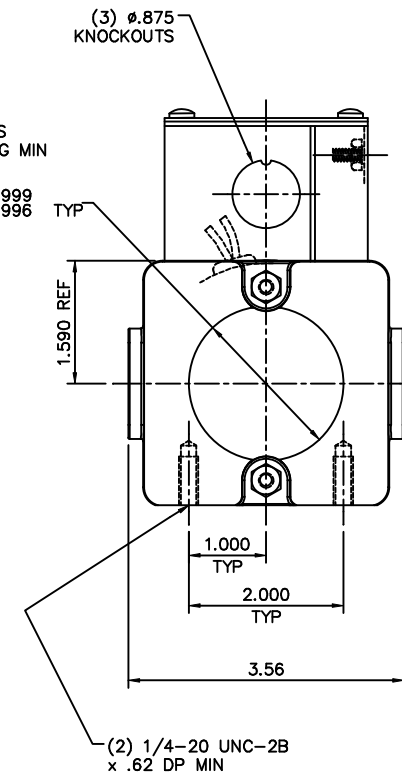
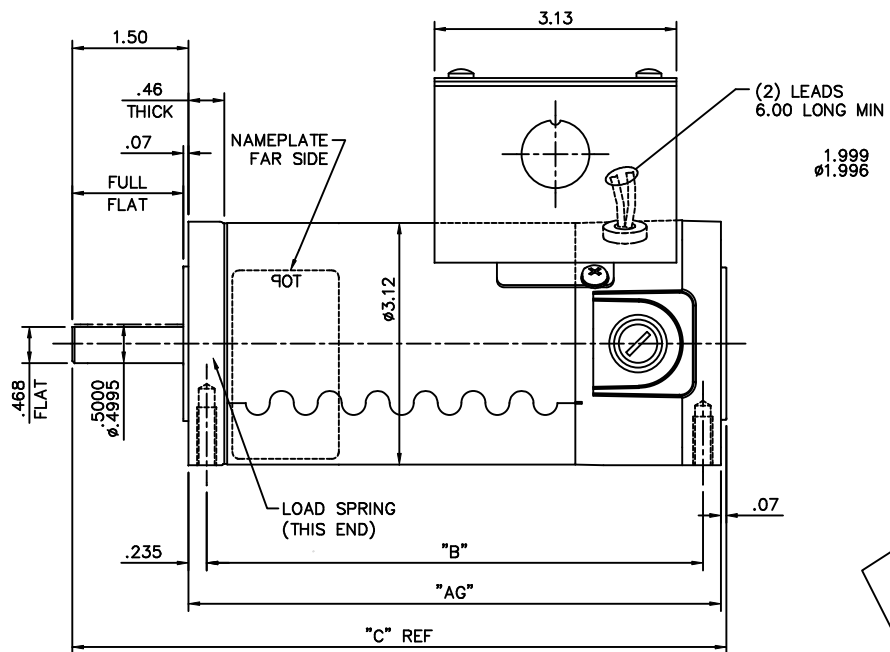
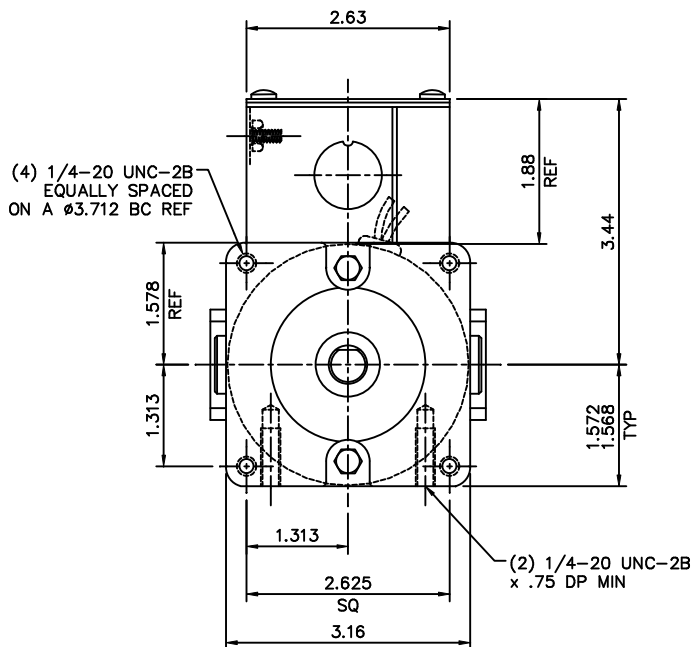

M1120062.00	7.88	7.42	9.45	90	1/4	3500
M1120060.00	5.38	4.92	6.95	90	1/10	3500
M1120059.00	5.88	5.42	7.45	90	1/8	3500
M1120058.00	6.88	6.42	8.45	90	1/6	3500
M1120045.00	6.88	6.42	8.45	180	1/8	1750
M1120043.00	7.88	7.42	9.45	180	1/6	1750
M1120042.00	7.88	7.42	9.45	90	1/6	1750
M1120041.00	6.38	5.92	7.95	180	1/10	1750
M1120040.00	4.88	4.42	6.45	12/24	1/14-1/7	1750/4200
M1120039.00	5.38	4.92	6.95	180	1/15	1750
M1120027.00	6.88	6.42	8.45	90	1/8	1750
M1120014.00	5.88	5.42	7.45	90	1/10	1750
M1120013.00	5.38	4.92	6.95	90	1/15	1750
CATALOG NO.	"AG" DIM	"B" DIM	"C" DIM	VOLT	H.P.	RPM

NOTES:  
 1) END CAP MOUNTING FEET TO BE PARALLEL TO EACH OTHER WITHIN .002

14	ADDED M1120060.00 TO TABLE, ECN 07-1640	IPG	5/18/07	SAD	TOLERANCES UNLESS SPECIFIED	ELECTRIC MOTORS GEARMOTORS AND DRIVES	DRAWN	IPG 11/9/06	
13	ADDED M1120059.00 TO TABLE, ECN 07-1638	IPG	5/18/07	SAD	DEC.		INCHES	CHK	SAD 11/9/06
12	CAT. M1120040.00: "AG" WAS 5.38, "B" WAS 4.92, "C" WAS 6.95, ECN 07-1635	IPG	5/18/07	SAD	.X		±.1	APPD	
11	ADDED M1120058.00 TO TABLE, ECN 07-1637	IPG	5/17/07	SAD	.XX		±.03	SCALE	5=8
10	ADDED M1120027.00 TO TABLE, ECN 07-1633	IPG	5/16/07	SAD	.XXXX	±.0005	TITLE	OUTLINE 31 FRAME DC	
NO.	REVISION	BY & DATE	CHK	ANG	±1/2"	FINISH	REF	M1030240.00	
THIS DRAWING IN DESIGN AND DETAIL IS OUR PROPERTY AND MUST NOT BE USED EXCEPT IN CONNECTION WITH OUR WORK ALL RIGHTS OF DESIGN AND INVENTION ARE RESERVED THIS IS AN ELECTRONICALLY GENERATED DOCUMENT - DO NOT SCALE THIS PRINT						MAT'L	FMF	M1120014.00	
RFP	CAD FILE		M1031034	SIZE	DRAWING NO.	REV.			
DIST	B		M1031034.00	14					

D.C. MOTORS

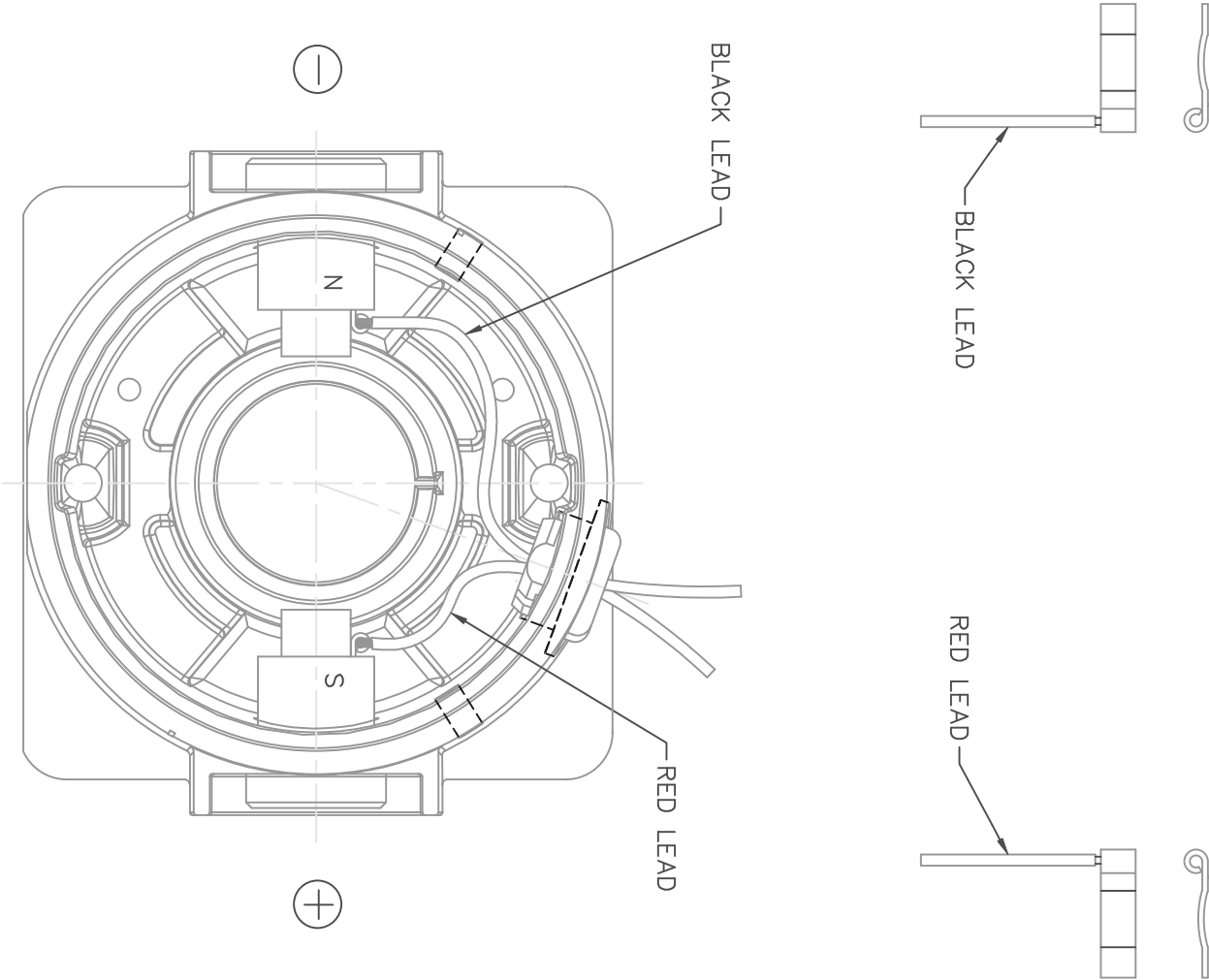

EXTERNAL CONNECTIONS FOR CCW ROTATION  
 VIEWING LEAD END OF MOTOR WITH RED LEAD  
 POSITIVE (+) AND BLACK LEAD NEGATIVE (-).  
 FOR CW ROTATION REVERSE POLARITY.

				TOLERANCES UNLESS SPECIFIED		 ELECTRIC MOTORS GEARMOTORS AND DRIVES	DRAWN IPG 11/6/06 CHK SAD 11/6/06 APPD SCALE 1=1 REF M1005036.01 FMF M1120014.00 PREV	
				DEC.	INCHES		TITLE	CONNECTION DIAGRAM
				.X	±.1			
				.XX	±.01			
				.XXX	±.005			
00	RELEASED PER 31 TT FR CONSOLIDATION, ECN 06-4430	IPG	11/6/06	SAD	.XXXX	±.0005	MAT'L.	
NO.	REVISION	BY & DATE		CHK	ANG	±1/2'	FINISH	
THIS DRAWING IN DESIGN AND DETAIL IS OUR PROPERTY AND MUST NOT BE USED EXCEPT IN CONNECTION WITH OUR WORK ALL RIGHTS OF DESIGN AND INVENTION ARE RESERVED THIS IS AN ELECTRONICALLY GENERATED DOCUMENT - DO NOT SCALE THIS PRINT				RFP	CAD FILE		SIZE	
				DIST	M1005321		DRAWING NO.	
							A	
							M1005321.01	
							REV.	
							00	

# LEESON ELECTRIC CORPORATION

## TYPICAL PERFORMANCE CURVE FOR DIRECT CURRENT PERMANENT MAGNET MOTOR

Model No. CM31D35NZ6

Catalog No. M1120058.00

HP 0.167 RPM 3500 DC Volts 90.0 N.P. FLA 1.90

F.F. 1.38 Encl TENV Type DN S.F. 1.00

Max. Amb. 40.0 Deg C Insul. H Frame 31 Duty CONT

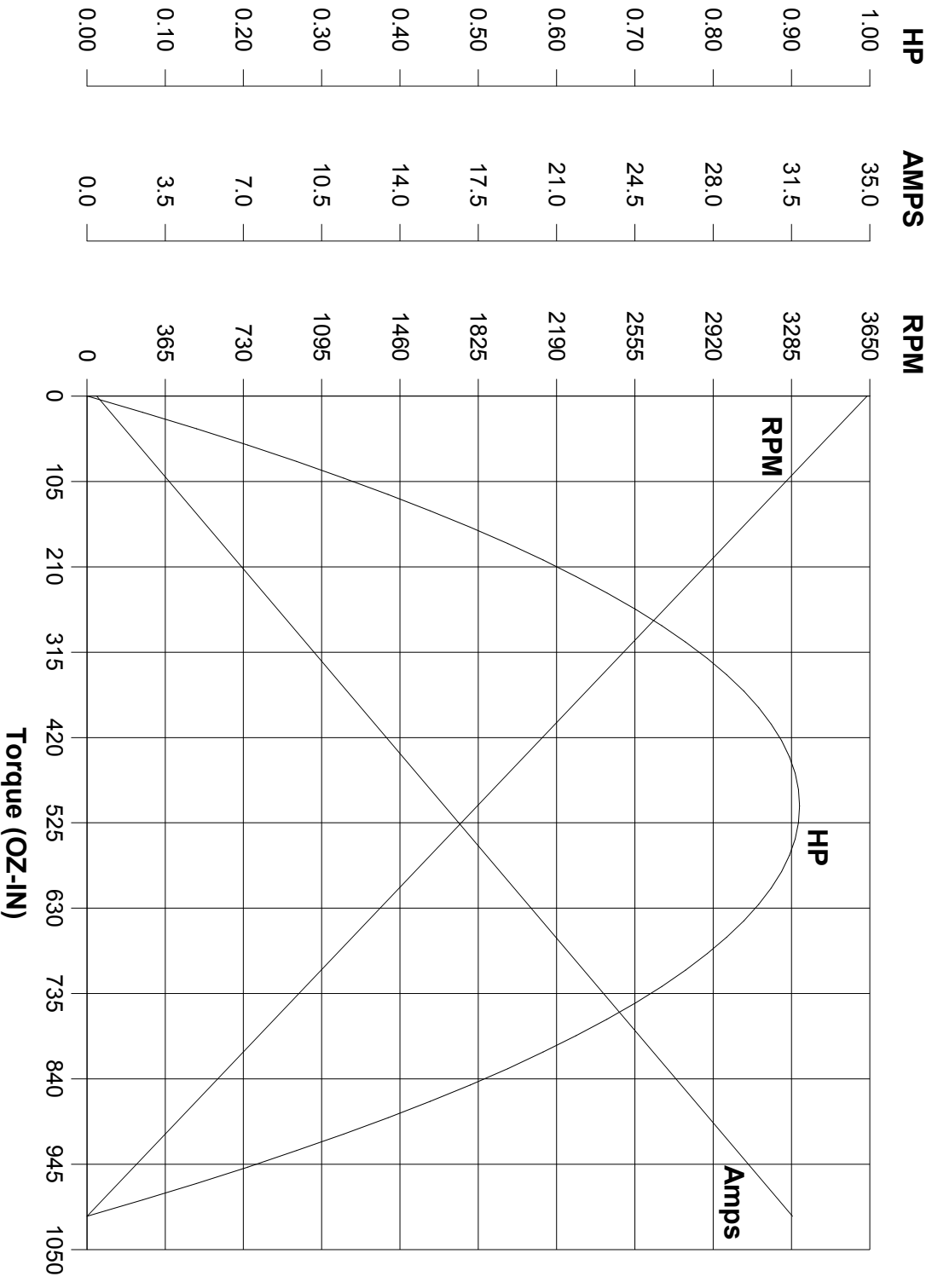

Ra 1.9600 Ohms  
 La 9.940 mHenrys  
 Ja 7.084 OZ-IN<sup>2</sup>  
 Ke 24.50 V/KRPM

Kt 33.13 OZ-IN/AMP  
 I<sub>max</sub> 32.3 AMPS Allowed  
 FL Torque 48.00 OZ-IN  
 FL EFF 73.30 %

Winding W- MD312363 Prepared by V. Boehlen Date 02-08-2012