

PRODUCT INFORMATION PACKET

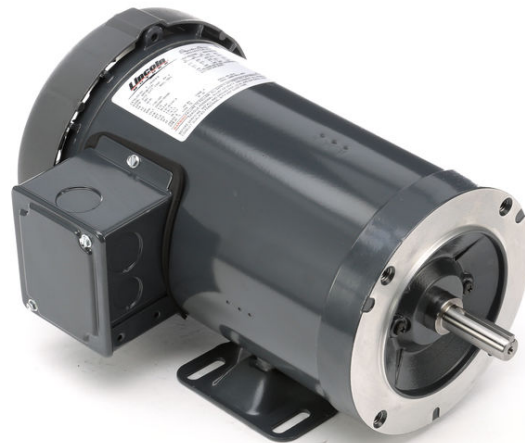

Model No: SRF6S0.5TC61
Catalog No: LM24104
1/2, 1140, TEFC, 56C, 3/60/208-230/460
Totally Enclosed Fan Cooled (TEFC)



Regal and Leeson are trademarks of Regal Beloit Corporation or one of its affiliated companies.
©2018 Regal Beloit Corporation, All Rights Reserved. MC017097E





Nameplate Specifications

Output HP	0.50 Hp	Output KW	0.37 kW
Frequency	60 Hz	Voltage	230/460 V
Current	2.7/1.4 A	Speed	1140 rpm
Service Factor	1.15	Phase	3
Efficiency	68 %	Duty	Continuous
Insulation Class	F	Design Code	B
KVA Code	L	Frame	56Z
Enclosure	Totally Enclosed Fan Cooled	Overload Protector	No
Ambient Temperature	40 °C	Drive End Bearing Size	203
Opp Drive End Bearing Size	203	UL	Recognized
CSA	Y	CE	N
IP Code	43		

Technical Specifications

Electrical Type	Squirrel Cage Induction Run	Starting Method	Across The Line
Poles	6	Rotation	Reversible
Mounting	Rigid base	Motor Orientation	HORIZONTAL
Drive End Bearing	BALL	Opp Drive End Bearing	BALL
Frame Material	Rolled Steel	Shaft Type	Single Special Extension
Overall Length	11.81 in	Frame Length	6.56 in
Shaft Diameter	0.625 in	Shaft Extension	1.88 in
Assembly/Box Mounting	F1 ONLY		
Outline Drawing	A-100110LN-656	Connection Diagram	A-EE7308-LN

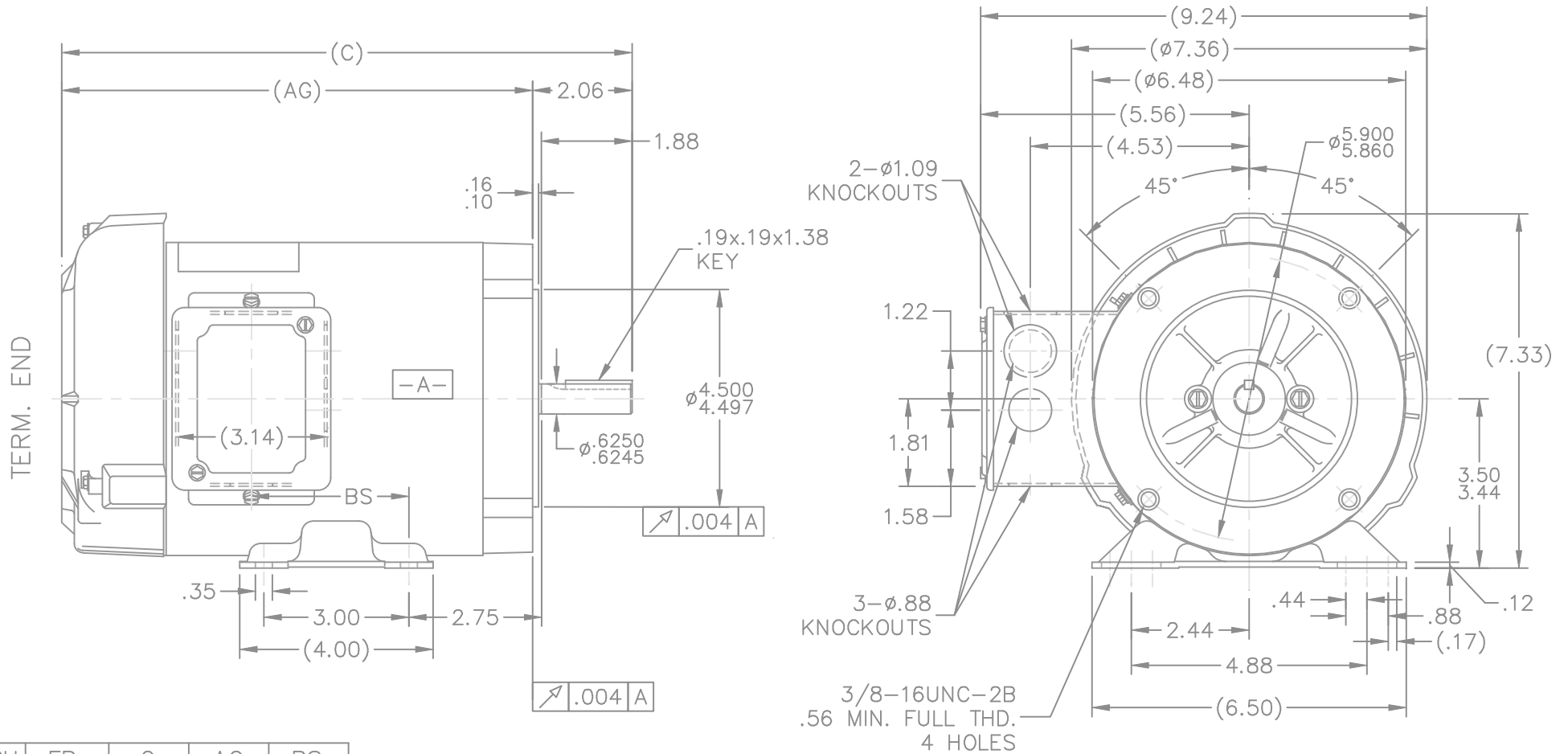

- NOTES:
1. CONDUIT BOX CAN BE ROTATED 180°.
 2. NAMEPLATE READ FROM CONDUIT BOX SIDE OF MOTOR.

DASH	FR.	C	AG	BS
606	56-60	11.31	9.25	2.75
656	56-65	11.81	9.75	3.25
706	56-70	12.31	10.25	3.75
756	56-75	12.81	10.75	4.25

06-01-2000

		TOLERANCES UNLESS SPECIFIED				DRAWN BLR 06-10-1999		
		DEC.	INCHES			CHK ML 06-18-1999		
		.X	±.1	TITLE OUTLINE		APPD GK 06-18-1999	SCALE 5=16	
2	ADDED NAMEPLATE LOC. CN27400-296	BLR 08-05-1999	.XXX ±.005	56 FRAME - TEFC - C'FACE		REF		
1	NEW DRAWING	BLR 06-18-1999	.XXXX ±.0005	MAT'L.		FMF		
NO.	REVISION	BY & DATE	CHK	ANG	±'30"	FINISH	PREV	
			RFP	06-18-1999	CAD FILE	100110ln	SIZE	DRAWING NO. PAGE 1 OF 1 REV.
			DIST	WP			A	100110LN 2

THIS DRAWING IN DESIGN AND DETAIL IS OUR PROPERTY AND MUST NOT BE USED EXCEPT IN CONNECTION WITH OUR WORK ALL RIGHTS OF DESIGN AND INVENTION ARE RESERVED THIS IS AN ELECTRONICALLY GENERATED DOCUMENT - DO NOT SCALE THIS PRINT

THREE PHASE
DUAL VOLTAGE MOTOR

HIGH VOLTAGE

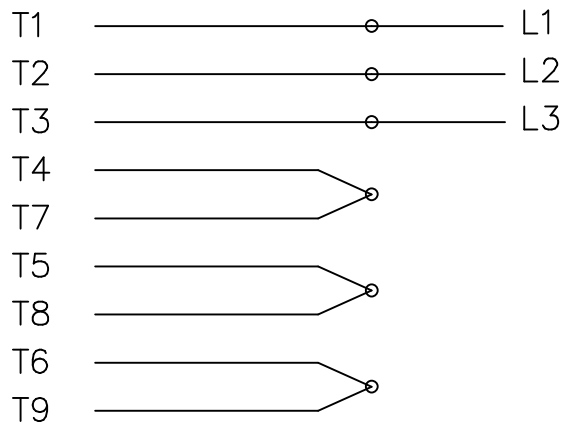

LOW VOLTAGE



VIEW OF TERMINAL END

REF.
WINDING DIAGRAM

T8Y, T2Y, T2BL, T4BX, T2EC, T2G
T6BZ, T2B, T6BL, T4AV, T6B, T4B

OPTIONAL CORD
CONNECTION

L1 — WHITE
L2 — RED
L3 — BLACK

NO.	REVISION	BY & DATE	CHK	TOLERANCES UNLESS SPECIFIED		FINISH	DRAWN	DATE				
				DEC.	INCHES							
				.X	±.1		BLR	06/11/1999				
							ML	06/18/1999				
							GK	06/18/1999				
3	ADDED THE OPTIONAL CORD CONNECTION MU46318	RDH 04/24/2003	DRS	.XX	±.02	TITLE CONNECTION DIAGRAM		SCALE 1=1				
2	RE-ISSUE, ADDED '-' TO PART NUMBER	BLR 08/09/1999	GK	.XXX	±.005	3Ø - DUAL VOLTAGE MOTOR		REF				
1	NEW DRAWING	BLR 06/18/1999	GK	.XXXX	±.0005	MAT'L.		FMF				
				ANG	±7'30"			PREV				
THIS DRAWING IN DESIGN AND DETAIL IS OUR PROPERTY AND MUST NOT BE USED EXCEPT IN CONNECTION WITH OUR WORK ALL RIGHTS OF DESIGN AND INVENTION ARE RESERVED THIS IS AN ELECTRONICALLY GENERATED DOCUMENT - DO NOT SCALE THIS PRINT				RFP	CAD FILE EE7308LN			SIZE	DRAWING NO.	PAGE	OF	REV.
				DIST	WP		A	EE7308-LN				3





Motor Load Data						
Load	0%	25%	50%	75%	100%	LR
Current (Amps)	1.20	1.20	1.20	1.20	1.35	6.2
Torque (ft-lb)	0.00	0.56	1.10	1.70	2.30	7.2
RPM	1200	1190	1180	1160	1140	0
Efficiency (%)		42.5	58.5	66.5	68.0	71.0
P.F. (%)	13.5	24.0	34.5	44.0	52.3	57.5

Motor Speed Data						Information Block																					
	LR	Pull-Up	BD	Rated	Idle	HP	Sync. RPM	Frame	Enclosure	Construction	Voltage	Frequency	Design	LR Code letter	Service Factor	Temp Rise @ FL	Duty	Ambient	Elevation	Rotor/Shaft wk ²	Ref Wdg	Sound Pressure @ 1M	VFD Rating	Outline Dwg	Conn. Diag	Additional Specifications:	
Speed (RPM)	0	600	890	1140	1200	0.5	1200	56	TEFC	TFR	230/460#190/380	60	B	L	1.15	60	CONT	40 °C	1,000 feet	Z1606 NONE		62	NONE	A-100110LN-656	A-EE7308-LN		
Current (Amps)	6.2	5.8	4.0	1.35	1.20																						
Torque (ft-lb)	7.2	6.5	9.0	2.30	0.00																						

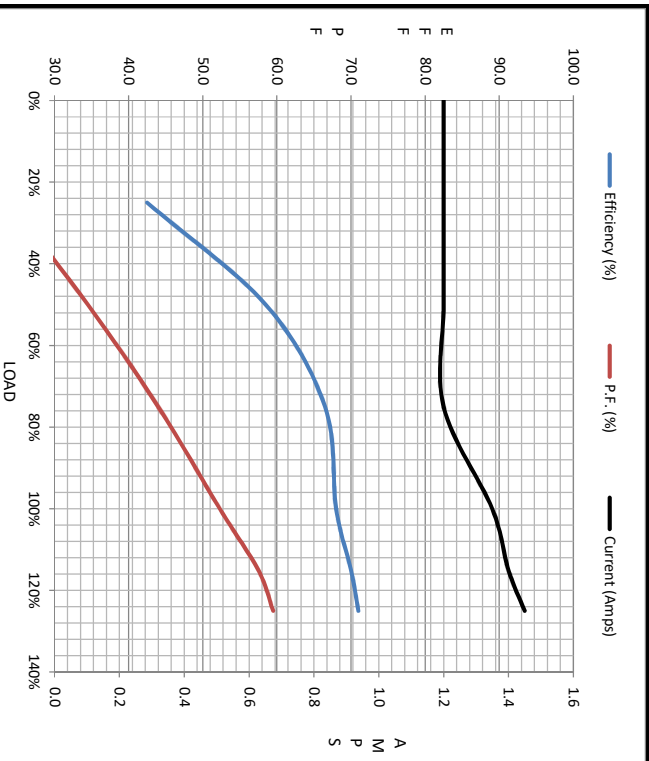

EQUIV CKT (OHMS / PHASE)			
R1	R2	X1	Xm
22.6800	11.3400	22.6800	22.6800 215.4600

