



World Class LEAD SCREW Assemblies

Linear Motion Solutions

Patented Constant Force Nut

Screw Nut Sets

06 mm, 10 mm, 12 mm, 16 mm
3/16", 1/4", 3/8", 7/16", 1/2"

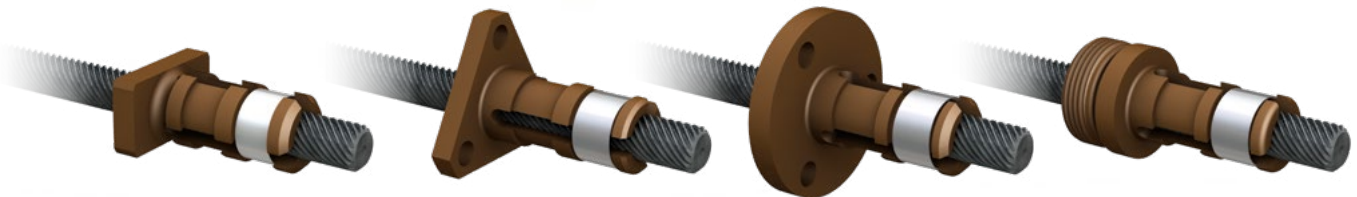

Integrated Motor & Screws

NEMA 08, 11, 14, 17, 23

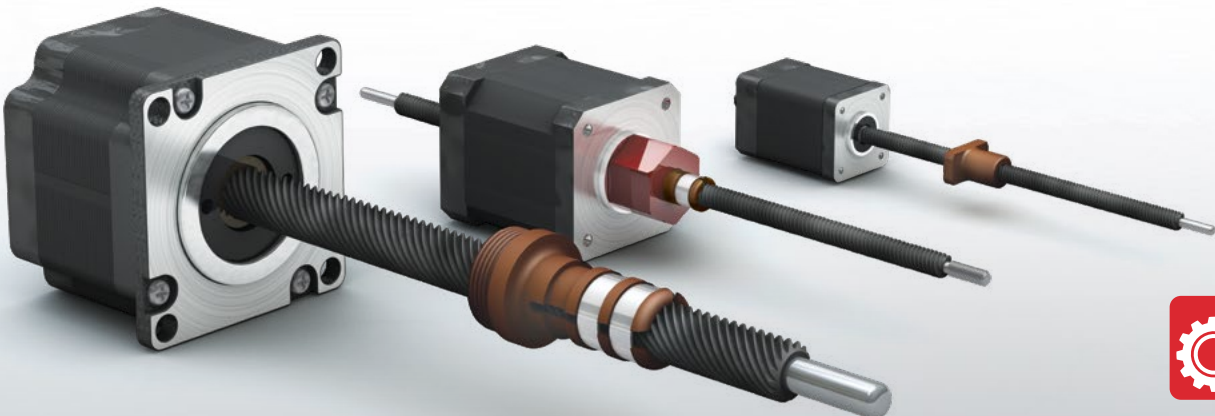

Configure Online at
pbclinear.com

1-800-962-8979

Engineering Your Linear Motion Solutions



PBC Linear maintains a commitment to bring improved linear motion solutions to market. Since 1983, its goal has been to provide innovative solutions through the development and manufacturing of linear motion components, mechanical sub-assemblies, and customized systems to meet customers' application and product needs and specifications.

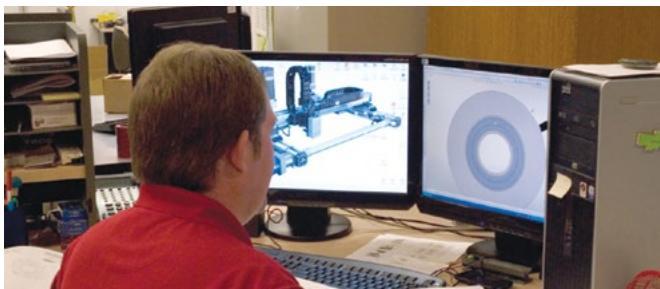

The diverse staff of engineers at PBC Linear combine in-depth industry knowledge and decades of experience with a collaborative approach to meet the linear motion requirements of each application.

Global Footprint

Headquartered with their main manufacturing facilities in the USA, PBC Linear also has locations in Europe, and SINO Asia, situated to support your production needs globally.

Manufacturing Agility

Headquartered in Roscoe, Illinois, USA, PBC Linear production is maximized to produce unmatched quality and designed specifically for the most complex and meticulous applications resulting in ready to install solutions.



This allows PBC Linear to provide quiet, smooth, and reliable linear motion in a wide array of applications, ranging from very small pick-and-place assemblies and scanners used in lab automation, to heavy-duty lift systems used in industrial manufacturing.



Core Competencies

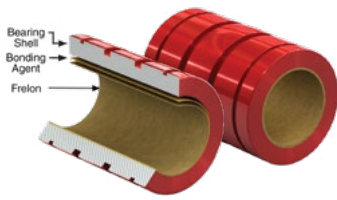

Simplicity Plain Bearings Bonding of Polymer and Fluoropolymer to Metals

Developed and refined over 26 years, linear plain bearings excel where traditional ball bearings fail.

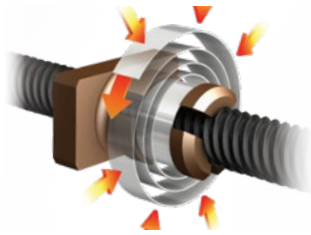

Anti-Backlash Lead Screw Nut

Constant Force Technology is an intuitive leap forward in nut design for lead screw applications. The result is greater consistency in performance and life, and a greater resistance to backlash.



Highly accurate rail lengths with SIMO® process

The Simultaneous Integral Milling Operation (SIMO) qualifies the rail to tolerances that have 6x less bow, 2x less twist, and 2x better flatness.

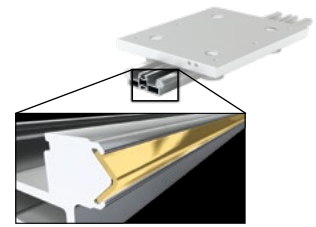

Joined aluminum and steel for longer rails

Integral-V rails and Redi-Rails® are produced by mechanically embedding hardened steel race ways onto an anodized aluminum profile. Precise, durable, and lightweight.



Configure Online
at pbclinear.com
1-800-962-8979



PBC Linear Technologies	Lead Screw	Simplicity	Roller Pillow Block	Gliding Surface	Integral-V	Cam Roller	Mechanics
Inexpensive	•	•	•	•	•	•	•
Low Maintenance	•	•	•	•			•
Compact Size	•			•			•
Low Noise	•	•					•
Multiple Configurations	•	•	•	•	•	•	•
Washdown Applications	•	•		•			•
Custom Design Support	•	•	•	•	•	•	•
Moderate to High Speed	•	•	•	•	•	•	•
Vacuum and Cleanroom Applications	•	•		•			•
Food Processing	•	•	•	•			
Ease of Installation	•				•	•	•



Screws • p 18–24



Standard
Stainless
Steel Threads

PTFE
Coated
Threads

Metric Sizes

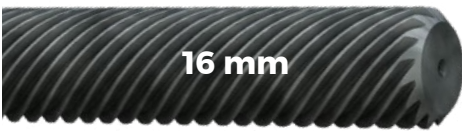

16 mm



12 mm



10 mm



6 mm

Leads

1, 2, 4, 5, 6, 8, 10,
12, 16, 25 mm

1, 2, 4, 5, 6, 8, 10,
12, 16, 25 mm

1, 2, 4, 5, 6, 8, 10,
12, 16, 25 mm

1, 2, 4, 5, 6, 8, 10,
12 mm

Inch Sizes



1/2"



7/16"



3/8"



1/4"



3/16"

Leads

0.25", 0.10"

1.00"

0.20"

0.333"

0.05", 0.50"

Nuts • p 18–24

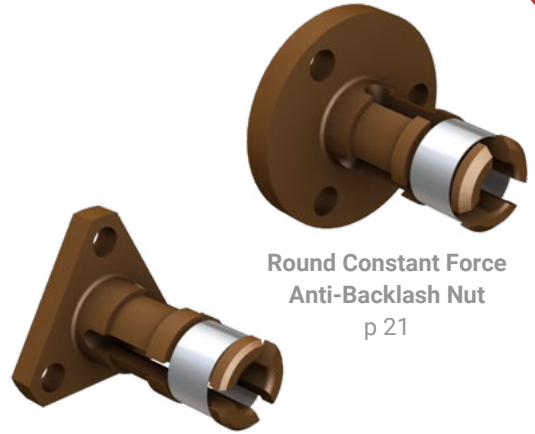

Round Constant Force
Anti-Backlash Nut
p 21

Triangle Constant Force
Anti-Backlash Nut
p 19

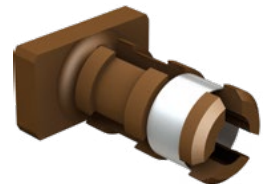

Rectangle Constant Force
Anti-Backlash Nut
p 24



Threaded Constant Force
Anti-Backlash Nut
p 23



Round
Standard Nut
p 20



Rectangle
Standard Nut
p 24



Threaded
Standard Nut
p 22



Triangle
Standard Nut
p 18

Motors • p 30–59

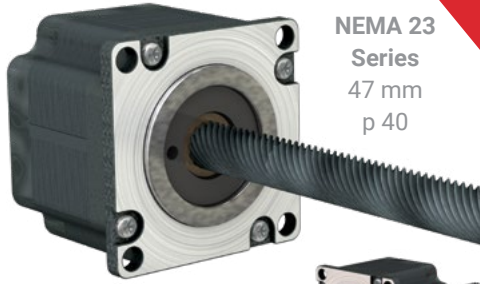

NEMA 23 Series
47 mm
p 40

Non-Captive Version p 56

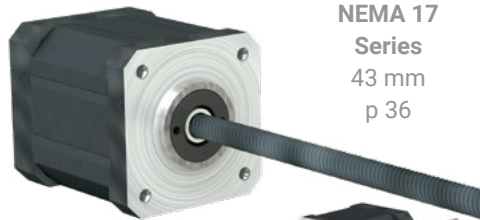

NEMA 17 Series
43 mm
p 36

Non-Captive Version p 52

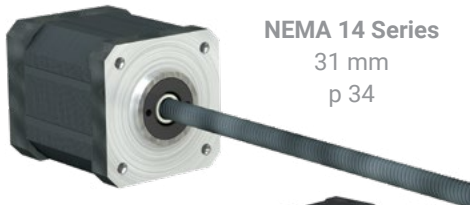

NEMA 14 Series
31 mm
p 34

Non-Captive Version p 48



NEMA 11 Series
23 mm
p 32

Non-Captive Version p 46



NEMA 8 Series
16 mm
p 30

Journalled Ends • p 25–26



Float Journal



Float Journal with Flat



Threaded Journal



Float Journal with Keyway



Fixed Journal



Fixed Journal with Flat



Float with Journal End



Fixed Journal with Keyway



Fixed with Journal End

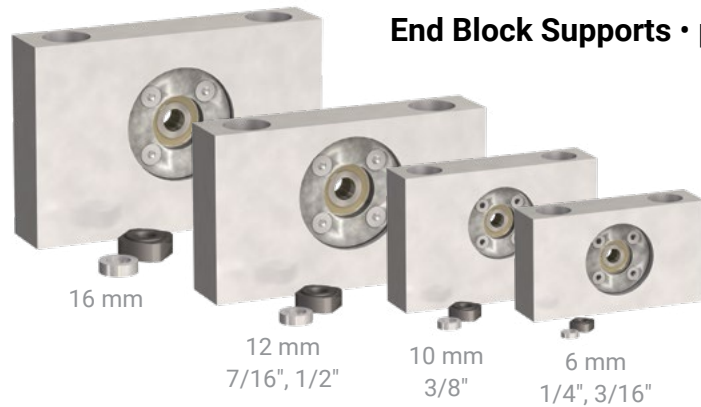

End Block Supports • p 27

16 mm

12 mm
7/16", 1/2"

10 mm
3/8"

6 mm
1/4", 3/16"

Table of Contents

Roll Threading Process Overview	p 4–7
PBC Linear Partnership Model	p 8–9
Lead Screw Thread Terminology	p 11
Lead Screw Overview	p12
Lead Screw Configuration Factors	p 14
Lead Screw Speed Charts	p 15
Lead Screw Load Charts	p16
Lead Screw PV Load Derate Charts	p17
Lead Screw Motors Overview	p28–29
Part Number Configurator	p 13,61
Non-Captive Part Number Configurator	p 45
Wiring Harnesses Diagram	p60
Full Line of PBC Linear Actuators	p63–65

World Class Precision German Roll Threading



To ensure the highest level of lead accuracy, key process variables such as speed, skew, temperature, and coolant flow are precisely monitored.

CNC controlled machinery provides precision process adjustment and control.

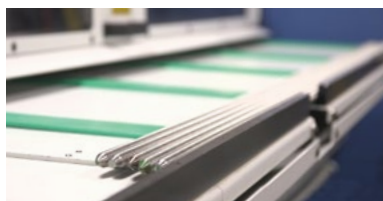

Automated in-feed and out-feed provide consistency over the full length of the screw stock.

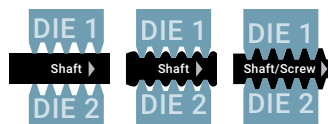
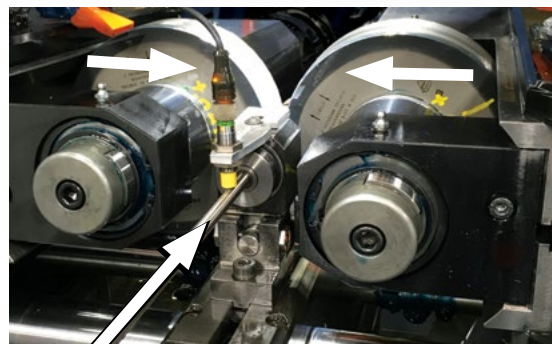

Quality Inspections



Microscopic inspections of the surface finish occurs at each stage of the manufacturing and coating process.



Competitor Screw Surfaces



Pitting and Fissures



Surface Roughness

CNC Straightening

The only automated straightening process in the USA, yielding the highest straightness tolerances available in a lead screw.

Smoother finish makes for longer product life.

This process eliminates errors that are inherent to manual processes.

Minimizes runout which can cause vibration, noise, and premature wear.

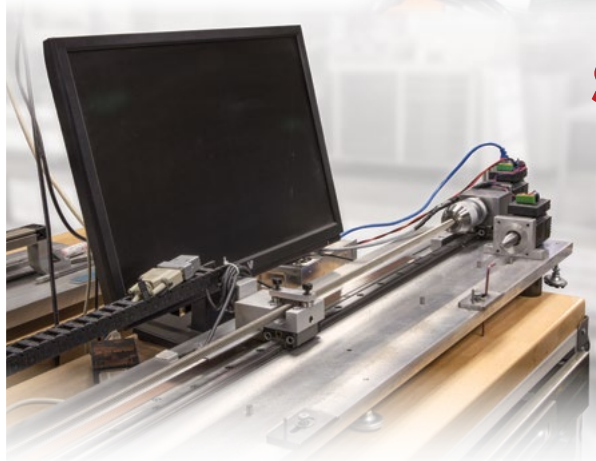

Superior Lead Accuracy

PBC Linear inspects 100% of the screw length (Up to 20,000 points over 72" compared to the competitors data point every 6 inches over the same length).

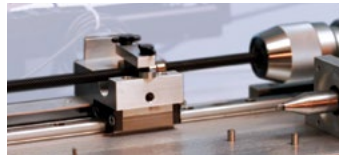

Lead accuracy of 0.003"/ft. (76 μ m/300 mm), 3 times better than typical industry specifications.

Climate Controlled, In-House Coating

Developed in-house, this custom coating process and equipment increases the quality of finish and eliminates screw flaking.

Coating reduces coefficient of friction, increasing screw efficiency and extending life.

Each screw is inspected with a digital microscope to ensure there is no flaking or pitting in the coating surface.



Built for a Long Life of Linear Motion

Pairing a Quality Screw with an Innovative Anti-Backlash Nut

Constant Force Technology nut utilizes a spring that applies uniform radial pressure to the nut at all stages of the motion profile.



Available in various geometries for quick customization.

CFT Nut Advantages:

- Greater than 2 times superior backlash compensation (Confirmed by leading lab automation customer validation testing)
- Consistent preload over life (Key for system level tuning and consistent performance over life)
- 2–4 times better than traditional designs, as validated by customer testing
- Self lubricated (Special PTFE nut formulation developed from 30 plus years of plain bearing knowledge)

Motors Built for Linear Motion

Lead screws are precision mounted and matched to a hollow shaft motor, then I.D. laser welded to the motor. The hollow shaft concentricity minimizes runout less than 0.003" (75 µm).

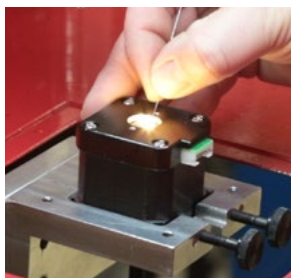
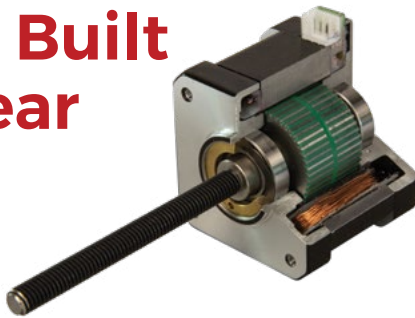

- Larger bearings increase thrust capacity and add longer life
- Preload on bearings removes axial play, reducing system backlash
- Optional smart motors



Nuts and assemblies are inspected to ensure backlash tolerances meet precise specifications.

Quality Testing



Two dedicated test labs are used to establish high performance characteristics.

One is designed for load and life where assemblies have run in excess of 2,500 miles without failure, and one is sound-proofed to analyze noise levels.



Thread Terminology

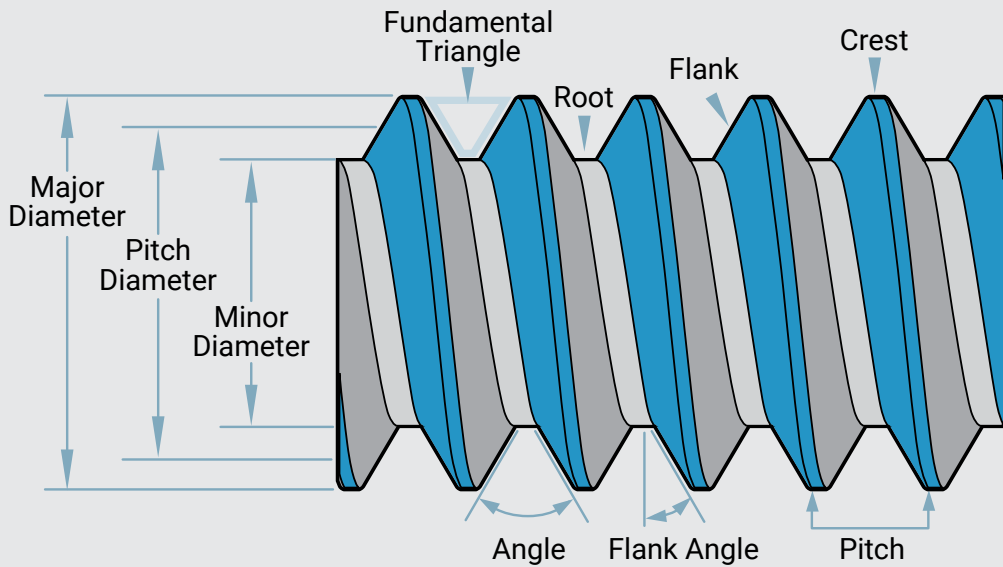

Single Start – Lead = Pitch

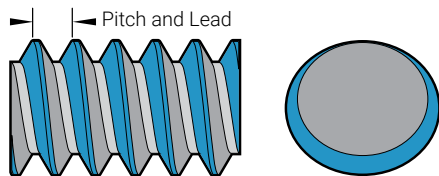

Two Start – Lead = 2 X Pitch

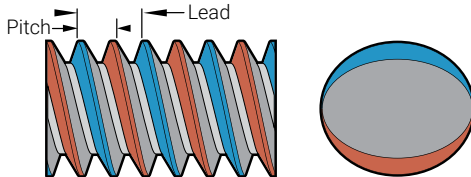

Four Start – Lead = 4 • Pitch

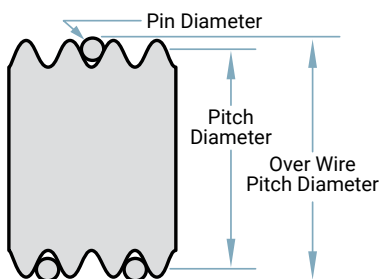
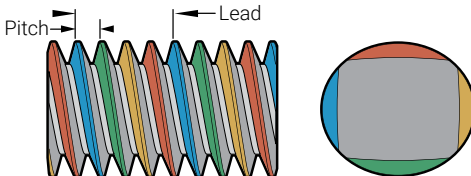

Pitch diameter is the diameter of a theoretical cylinder that passes through the threads in such a way that the distance between the thread crests and thread roots is equal. In an ideal product, these widths would each equal one-half of the thread pitch.

Lead angle is the angle made by the pitch helix, with a plane perpendicular to the axis.

Lead accuracy is the difference between the actual distance traveled versus the theoretical distance traveled based on lead.

Crests are the top of the threads.

Roots are the bottom of the threads.

Flanks are the surfaces between the crests and roots.

Pitch is the distance measured parallel to the thread axis, between corresponding points on adjacent threads.

Lead is the axial distance the nut advances in one revolution of the screw. The lead is equal to the pitch times the number of starts. $\text{Pitch} \cdot \text{starts} = \text{lead}$

Flank angle is the angle between a flank and the perpendicular thread axis. Flank angles are sometimes termed “half-angle” of the thread, but this is only true when neighboring flanks have identical angles (when the threads are symmetrical).

Actual pitch diameter is determined by subtracting the pin diameter times 2 from the measurement taken across the three thread wires.

Internal thread – the minor diameter occurs at the crests while the major diameter occurs at the roots.

External thread – the minor diameter occurs at the roots while the major diameter occurs at the crests.

Lead Screws & Nuts

300 Series Stainless Steel with PTFE Coating Option (72" length maximum available on all sizes (68"-69" useable)



Diameter	6 mm	10 mm	12 mm	16 mm	
Leads	1 mm	•	•	•	•
	2 mm	•	•	•	•
	4 mm	•	•	•	•
	5 mm	•	•	•	•
	6 mm	•	•	•	•
	8 mm	•	•	•	•
	10 mm	•	•	•	•
	12 mm	•	•	•	•
	16 mm		•	•	•
	25 mm		•	•	•

Inch Leads	3/16"	1/4"	3/8"	7/16"	1/2"
0.05"	•				
0.10"					•
0.20"			•		
0.25"					•
0.333"		•			
0.50"	•				
1.00"				•	

Metric Leads	Coating	Leadscrew / Nut - % Efficiency Metric Screw Diameter			
		6 mm	10 mm	12 mm	16 mm
1 mm	Coated	39	28	24	19
	Uncoated	30	21	18	14
2 mm	Coated	60	45	40	33
	Uncoated	51	36	31	25
4 mm	Coated	71	61	56	49
	Uncoated	62	52	47	40
5 mm	Coated	76	66	62	55
	Uncoated	68	57	53	45
6 mm	Coated	77	69	65	58
	Uncoated	70	61	56	49
8 mm	Coated	81	74	71	65
	Uncoated	75	66	62	56
10 mm	Coated	84	78	75	69
	Uncoated	78	71	67	61
12 mm	Coated	84	80	77	72
	Uncoated	81	74	70	64
16 mm	Coated	-	84	81	77
	Uncoated	-	78	75	70
25 mm	Coated	-	86	85	83
	Uncoated	-	83	81	77

Inch Leads	Coating	Leadscrew / Nut - % Efficiency IPS Screw Diameter				
		3/16"	1/4"	3/8"	7/16"	1/2"
0.05"	Coated	51	-	-	-	-
	Uncoated	41	-	-	-	-
0.10"	Coated	-	-	-	-	44
	Uncoated	-	-	-	-	35
0.20"	Coated	-	-	66	-	-
	Uncoated	-	-	57	-	-
0.250"	Coated	-	-	-	-	65
	Uncoated	-	-	-	-	56
0.333"	Coated	-	82	-	-	-
	Uncoated	-	76	-	-	-
0.50"	Coated	88	-	-	-	-
	Uncoated	84	-	-	-	-
1.00"	Coated	-	-	-	87	-
	Uncoated	-	-	-	82	-

The listed efficiencies are theoretical values calculated by assuming the coefficients of friction.

Lead accuracy: 76.2 micron/300 mm or 0.003"/ft

Diameter: 6 mm-16 mm or 3/16"-1/2"

Lead: 1 mm-25 mm or 0.05"-0.25"

Dynamic Load: Up to 1.16 kN or 260 lbs.

Backlash:

- **Constant Force Nuts** are designed to reduce or eliminate backlash. Generally, the higher the preload, the better the anti-backlash performance. Custom designs available
- **Standard Nut**, 0.025-0.25 mm (0.001-0.010")
Longer leads have greater backlash

Part Number Configurator

Configure



It Now

Type **LS** Thread Dir. **R** Diameter and Lead **0000** Coating **T** Screw Length **0250.00** Nut **RS** Left End **111** Right End **AFN** Special **E**

Type

LS - Lead Screw

Thread Direction

R - Right

L - Left (Note: Contact Factory)

Coating

T - PTFE

U - Uncoated

Screw Length

Inch - 0000.00

Metric - 0000

Note: Screw type selected determines if length is inch or metric.

Special

E - Encoder Ready

N - No Option

Diameter and Lead

Code	Diameter	Lead	
18050	3/16"	0.50"	
18005		0.05"	
25033	1/4"	0.333"	
37020	3/8"	0.20"	
43100	7/16"	1.00"	
50010	1/2"	0.10"	
50025		0.25"	
0601	6 mm	1 mm	
0602		2 mm	
0604		4 mm	
0605		5 mm	
0606		6 mm	
0608		8 mm	
0610		10 mm	
0612		12 mm	
1001		10 mm	1 mm
1002			2 mm
1004	4 mm		
1005	5 mm		
1006	6 mm		
1008	8 mm		
1010	10 mm		
1012	12 mm		
1016	16 mm		
1025	25 mm		
1201	12 mm	1 mm	
1202		2 mm	
1204		4 mm	
1205		5 mm	
1206		6 mm	
1208		8 mm	
1210		10 mm	
1212		12 mm	
1216		16 mm	
1225		25 mm	
1601	16 mm	1 mm	
1602		2 mm	
1604		4 mm	
1605		5 mm	
1606		6 mm	
1608		8 mm	
1610		10 mm	
1612		12 mm	
1616		16 mm	
1625		25 mm	

Lead Screw Standard Nuts

RS	Round
TS	Triangle
US	Threaded
VS	Rectangle

Lead Screw Anti-Backlash Nuts

RCF	Round
TCF	Triangle
UCF	Threaded
VCF	Rectangle

Sample Part Numbers

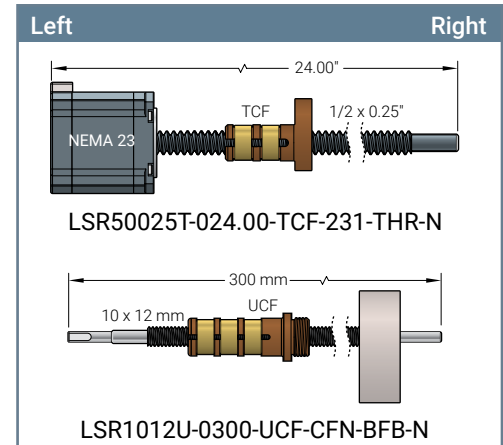

Left End Only

080	NEMA 8 (16 mm) (Requires a 3/16", 1/4" or 6 mm screw) Note: Not available with encoder ready option.
111	NEMA 11 (23 mm) (Requires a 3/16", 1/4" or 6 mm screw)
140	NEMA 14 (31 mm) (Requires a 3/16", 1/4", 6 mm or 10 mm screw)
171	NEMA 17 (43 mm), Single Stack (Requires a 1/4", 3/8", 6 mm, 10 mm or 12 mm screw)
172	NEMA 17 (43 mm), Double Stack (Requires a 3/8", 10 mm or 12 mm screw)
231	NEMA 23 (47 mm), Single Stack (Requires a 3/8", 7/16" 1/2" 10 mm, 12 mm or 16 mm screw)
232	NEMA 23 (47 mm), Double Stack (Requires a 3/8", 7/16" 1/2" 10 mm, 12 mm or 16 mm screw)
23P	NEMA 23 (47 mm), Power Plus (Requires a 3/8", 7/16" 1/2" 10 mm, 12 mm or 16 mm screw)

Left and/or Right Ends

AFN	Bearing Support Only, Float
ALN	Bearing Support Only, Fixed
BFN	Bearing Support & Journal, Float
BLN	Bearing Support & Journal, Fixed
CFN	Bearing Support & Journal with Keyway, Float*
CLN	Bearing Support & Journal with Keyway, Fixed*
AFB	Bearing Support Only, Float, with Bearing Block
ALB	Bearing Support Only, Fixed, with Bearing Block
BFB	Bearing Support & Journal, Float, with Bearing Block
BLB	Bearing Support & Journal, Fixed, with Bearing Block
CFB	Bearing Support & Journal With Keyway, Float, with Bearing Block*
CLB	Bearing Support & Journal With Keyway, Fixed, with Bearing Block*
THR	Threaded
NNN	None

* Keyways will be flat or a keyway based on screw diameter, see page 18
Flat for 6 mm, 10 mm, 3/16", 1/4", 3/8" diameters
Keyway for 12 mm, 16 mm, 7/16", 1/2" diameters

Lead Screw Configuration Factors

Sizing a Lead Screw and Stepper Motor Backdriving of a Lead Screw

The theoretical torque required to drive a load with a lead screw is:

$$Torque_{Drive} = \frac{Load \times Lead}{2 \pi \times Screw Efficiency}$$

where lead screw efficiencies are given on page 4.

To properly use the above formula, a customer first needs to estimate the total axial load that must be driven by the lead screw system. The estimated total load should include all mass loads, acceleration loads, system friction loads, and the nut drag load. Friction loads of an actuator or a bearing and rail system must be accounted for – especially if plane bearings or bushings are used. See nut detail pages for their drag load specifications.

Next, a customer can make a table of the estimated total loads at the important speeds of the application and use the above formula to calculate the estimated theoretical motor torque for each combination of lead screw diameter and lead of interest.

Having estimated the required motor torques and knowing the speeds of the application, a customer can check the motor torque-speed curves on pages 31 - 36 of the catalog to determine what stepper motor should be used. Note that it is common practice to ensure that a stepper motor can produce 1.5 - 2.0 times the torque required at all the speeds of an application. The multiplier of 1.5 - 2.0 helps compensate for variations in motor torque, friction, small misalignments, cable carrier drag, and other factors not generally accounted for in estimates of total load.

If the efficiency of a lead screw and nut is high enough, the lead screw can back-drive when an axial thrust force is applied to the nut. Generally, back-driving will not occur if the screw lead is less than 1/3 the diameter of an uncoated lead screw or 1/4 the diameter of a coated lead screw. Application of lubricant to a lead screw can lower the coefficient of friction of the lead screw & nut system and cause the ability to back-drive. A screw & nut system that experiences vibration will back-drive at a lower efficiency than a similar screw & nut system that does not experience vibration.

The theoretical brake torque required to hold a load is:

$$Torque_{Holding} = \frac{Load \times Lead \times Screw Efficiency}{2 \pi}$$

where lead screw efficiencies are given on page 4.

Other System Factors

Customers should also check that the lead screw's 80% critical speed limit, the maximum compressive column loading of the lead screw, and the PV derated nut load capacity are not exceeded per the charts on the following pages. Standard operating temperature range is 32°–180°F (0–82°C). If a customer has questions, Application Engineers at PBC Linear can be contacted for assistance.

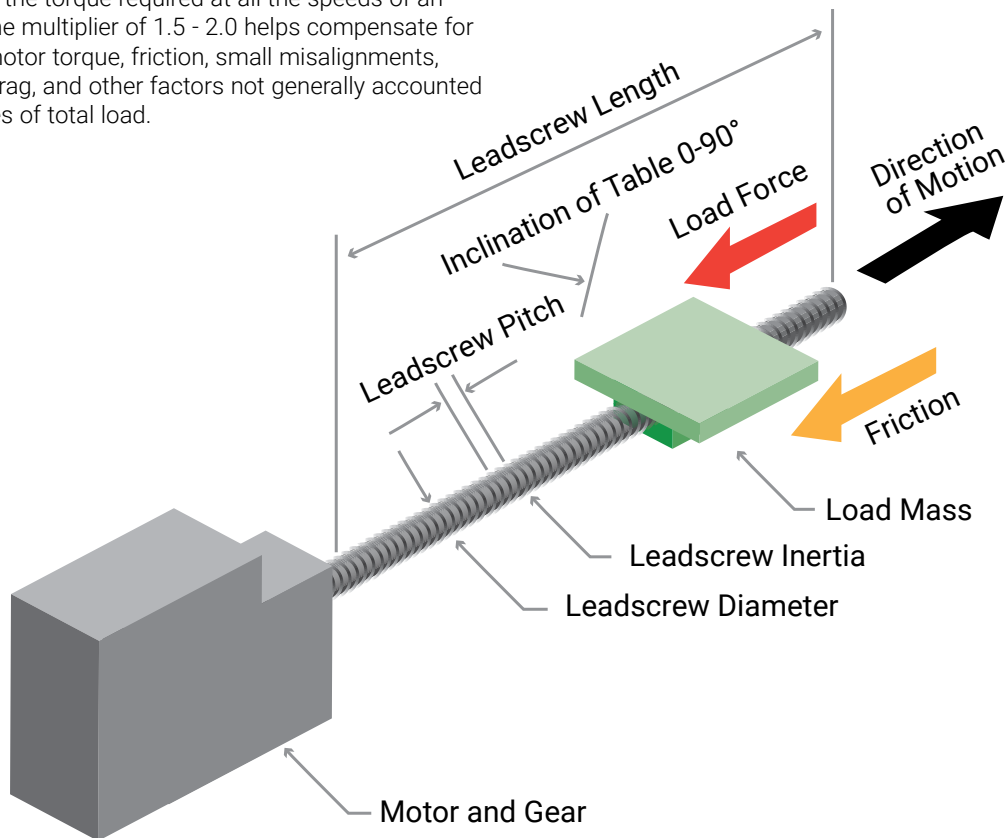

Lead Screw Speed Charts

80% Critical Speed - Metric

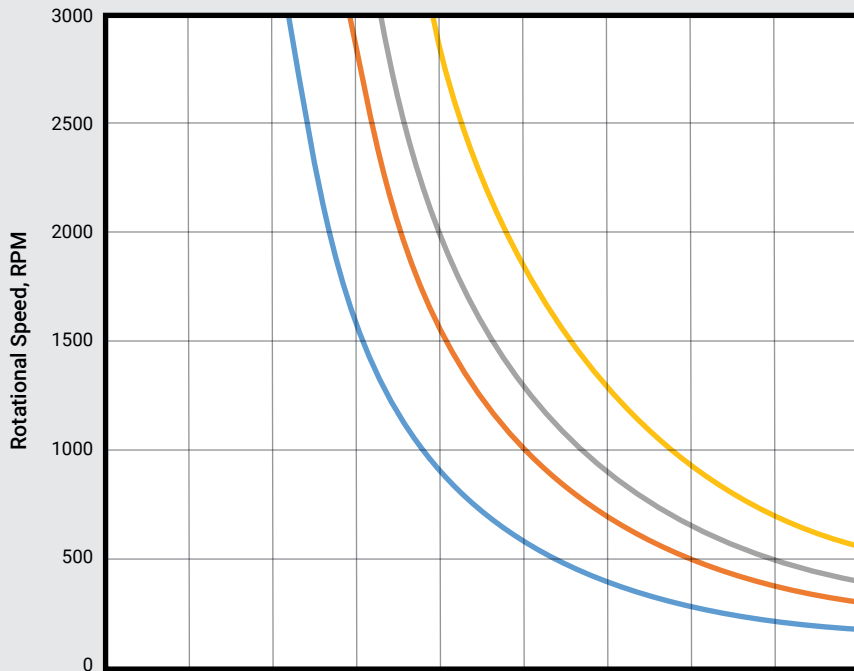

Fixed-Free	0	100	200	300	400	500	600	700	800	900
Simple-Simple	0	168	337	505	674	842	1010	1080	1350	1520
Fixed-Simple	0	210	420	631	841	1050	1260	1470	1680	1890
Fixed-Fixed	0	253	507	760	1010	1270	1520	1770	2030	2280

Maximum Length (mm) between Bearings

- Dia. 6 mm
- Dia. 10 mm
- Dia. 12 mm
- Dia. 16 mm

PBC Linear Recommends:

Lead screws should be sized to operate at or below 80% of the critical speed. Critical speed is the lowest rotational speed at which the screw shaft is in resonance.

Several factors help to determine critical speed including:

- Screw diameter
- Length between bearing supports
- Type of bearing supports used

80% Critical Speed - IPS

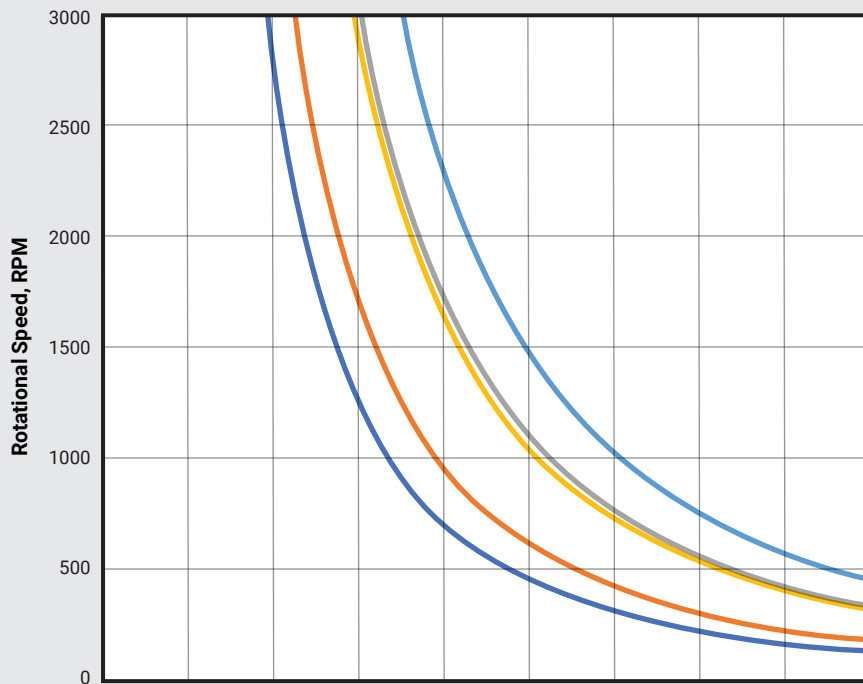

Fixed-Free	0	04.0	08.0	12.0	16.0	20.0	24.0	28.0	32.0	36.0
Simple-Simple	0	06.7	13.3	20.0	26.7	33.3	40.0	46.7	53.5	60.0
Fixed-Simple	0	08.1	16.2	24.2	32.3	40.4	48.5	56.6	64.7	72.7
Fixed-Fixed	0	10.0	20.0	30.0	40.0	50.0	60.0	70.0	80.0	90.0

Maximum Length (inches) between Bearings

- Dia. 3/16 inch
- Dia. 1/4 inch
- Dia. 3/8 inch
- Dia. 7/16 inch
- Dia. 1/2 inch

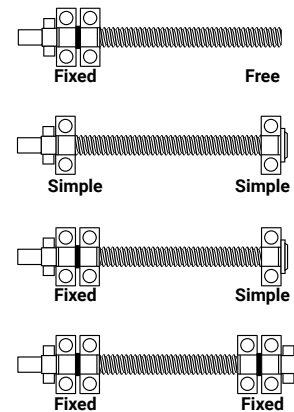

Lead Screw Load Charts

- 6 mm x (5, 12 mm)
- 6 mm x 2 mm
- 6 mm x (1,4,6,8,10 mm)
- 10 mm x (5,25 mm)
- 10 mm x (2,4,6,8,10,12,16 mm)
- 10 mm x 1 mm
- 12 mm x (5,10,25 mm)
- 12 mm x (2,4,6,8,12,16 mm)
- 12 mm x 1 mm
- 16 mm x (5,10,25 mm)
- 16 mm x (2,4,6,8,12,16 mm)
- 16 mm x 1 mm

PBC Linear Recommends:

Lead screws should be loaded in axial compression to levels below their maximum column loading.

Exceeding the maximum column loading can result in instability due to screw bending or buckling. These charts limit the screw slenderness ratios based on the type of screw support selected:

25 = Fixed - Free

50 = Simple - Simple

70 = Fixed - Simple

100 Fixed - Fixed

Please consult PBC Linear if your application exceeds these limits

- 3/16 x 0.5 inch
- 3/16 x 0.05 inch
- 1/4 x 0.333 inch
- 3/8 x 0.200 inch
- 7/16 x 0.125 inch
- 1/2 x 0.100 inch and 0.250 inch

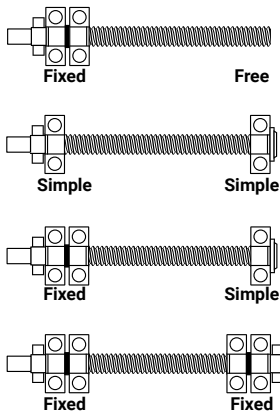

Maximum Column Loading - Metric

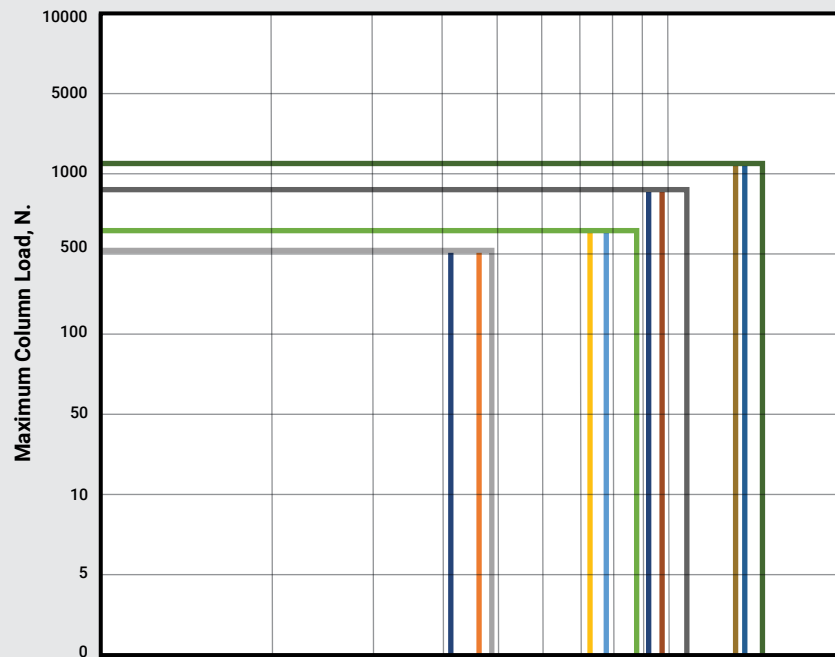

Fixed-Free	25	51	76	102	127	152	178	203	254	508
Simple-Simple	51	102	152	203	254	305	356	406	508	1016
Fixed-Simple	72	127	178	254	330	406	483	559	711	1448
Fixed-Fixed	102	203	305	406	508	610	711	813	1016	2032

Maximum Length (mm) between Bearings

Maximum Column Loading - IPS Units

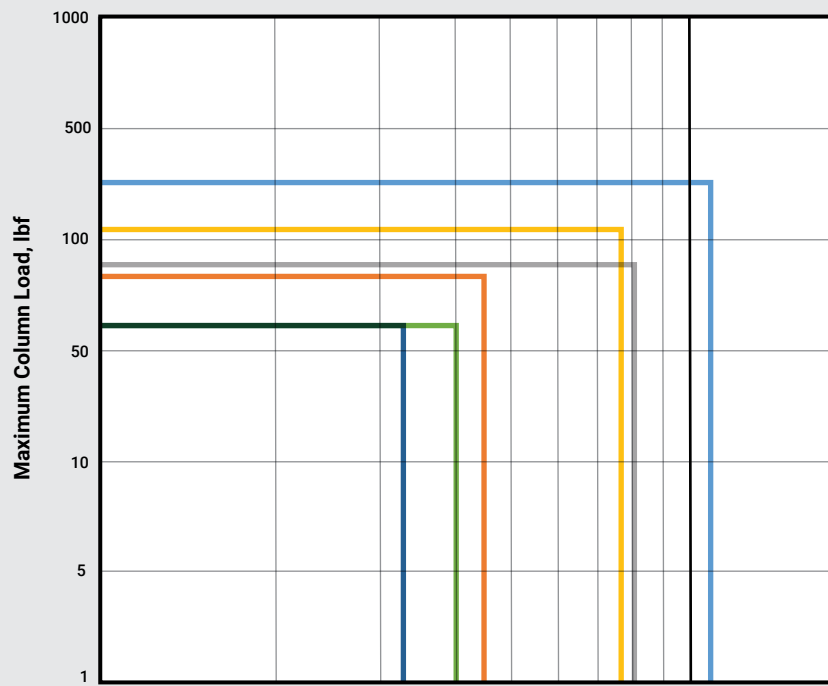

Fixed-Free	1.0	2.0	3.0	4.0	5.0	6	7	8	9.0	10	20
Simple-Simple	2.0	4.0	6.0	8.0	10.0	12	14	16	18.0	20	40
Fixed-Simple	2.8	5.7	8.5	11.3	14.1	17	20	23	25.5	28	57
Fixed-Fixed	4.0	8.0	12.0	16.0	20.0	24	28	32	36.0	40	80

Lead Screw PV Load Derate Charts

PBC Linear Load Derate Factor for Inch Lead Screw Nuts

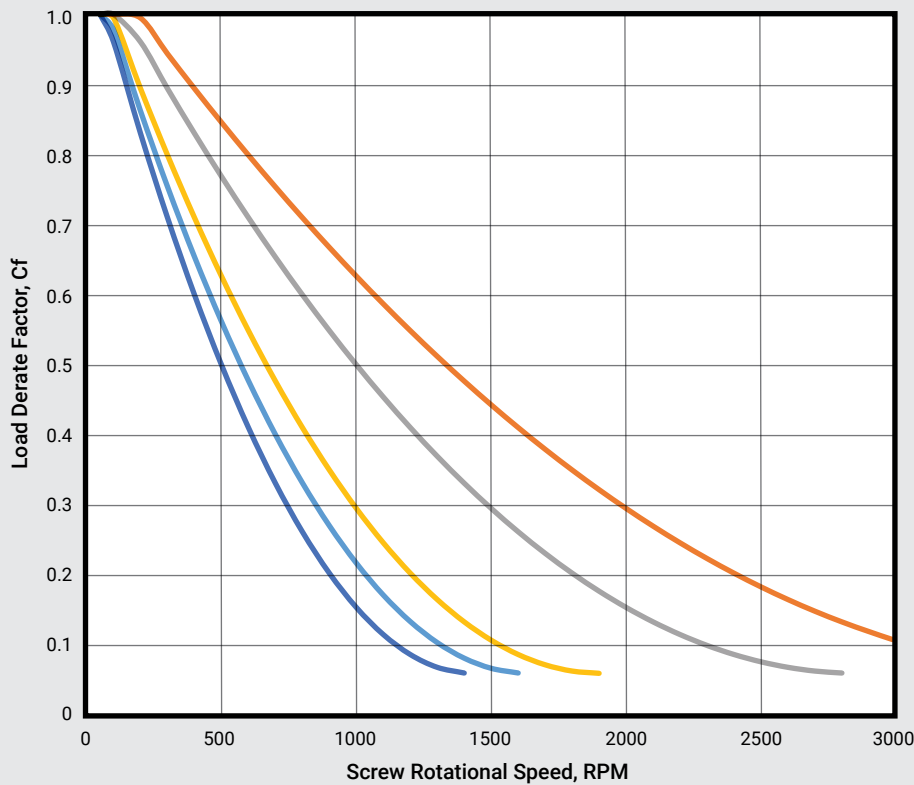

MAX Nut Load = Cf x Nut Dynamic Load Rating

Please note that the PV limit of the nut is dependent on the duty of the application and other factors so these curves are a guideline. If your application will operate near or beyond the shown curves, please contact PBC Linear for support.

- 0.188 inch Dia Screw
- 0.250 inch Dia Screw
- 0.375 inch Dia Screw
- 0.438 inch Dia Screw
- 0.500 inch Dia Screw

PBC Linear Recommends:

When determining if a lead screw nut has adequate load capacity for an application, multiply the maximum nut load capacity by the speed dependent factor listed on this page to determine the actual load capacity of the nut at the desired operating speed.

Operating at higher loads will result in accelerated nut wear.

PBC Linear Load Derate Factor for Metric Lead Screw Nuts

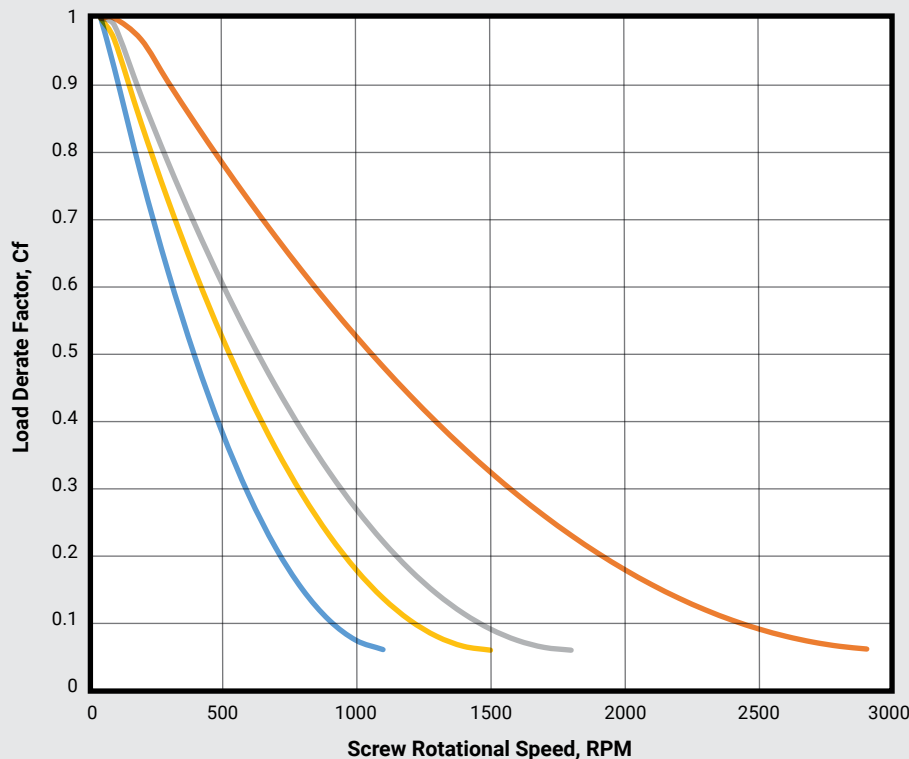

MAX Nut Load = Cf x Nut Dynamic Load Rating

Please note that the PV limit of the nut is dependent on the duty of the application and other factors so these curves are a guideline. If your application will operate near or beyond the shown curves, please contact PBC Linear for support.

- 6 mm Dia Screw
- 10 mm Dia Screw
- 12 mm Dia Screw
- 16 mm Dia Screw

Triangle Nut Standard

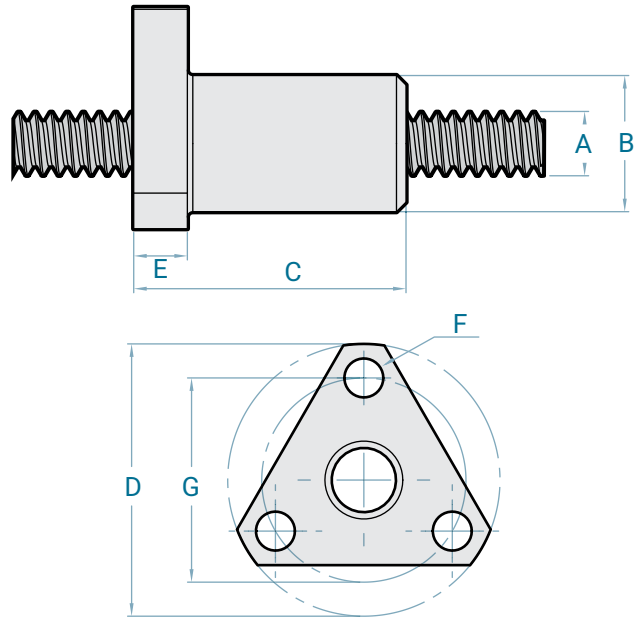
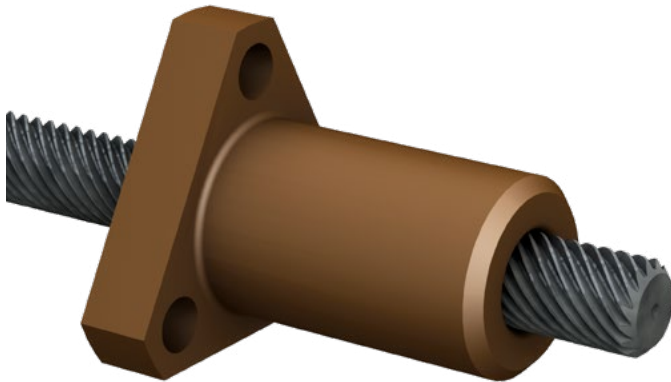

Metric Screws	A	B	C	D	E	F	G	Drag Torque (Nm)	Dynamic Load (N)
	Screw Diameter	Nut Dia. (mm)	Nut Length (mm)	Flange Dia. (mm)	Flange Thickness (mm)	Mounting Hole Dia. (mm)	Bolt Circle Dia. (mm)		
	6 mm	10.2	22.2	25.4	4.8	3.6	19.1	Free Wheeling	334 N
	10 mm	15.9	25.4	38.1	4.8	5.1	28.6	Free Wheeling	445 N
	12 mm	16.9	38.1	44.5	6.4	5.6	35.7	Free Wheeling	778 N
	16 mm	20.3	38.1	54.0	6.4	5.6	44.5	Free Wheeling	1,160 N

Inch Screws	A	B	C	D	E	F	G	Drag Torque (oz-in)	Dynamic Load (lb)
	Screw Diameter	Nut Dia. (in)	Nut Length (in)	Flange Dia. (in)	Flange Thickness (in)	Mounting Hole Dia. (in)	Bolt Circle Dia. (in)		
	3/16"	0.35	0.63	0.81	0.13	0.12	0.600	Free Wheeling	45
	1/4"	0.41	0.88	1.00	0.19	0.14	0.750	Free Wheeling	75
	3/8"	0.61	1.00	1.50	0.19	0.20	1.125	Free Wheeling	85
	7/16"	0.64	1.50	1.62	0.20	0.20	1.250	Free Wheeling	125
	1/2"	0.69	1.50	1.75	0.22	0.22	1.406	Free Wheeling	200

Screw Diameter	Metric Leads • Part Numbers									
	1 mm	2 mm	4 mm	5 mm	6 mm	8 mm	10 mm	12 mm	16 mm	25 mm
6 mm	LNR0601TS	LNR0602TS	LNR0604TS	LNR0605TS	LNR0606TS	LNR0608TS	LNR0610TS	LNR0612TS	-	-
10 mm	LNR1001TS	LNR1002TS	LNR1004TS	LNR1005TS	LNR1006TS	LNR1008TS	LNR1010TS	LNR1012TS	LNR1016TS	LNR1025TS
12 mm	LNR1201TS	LNR1202TS	LNR1204TS	LNR1205TS	LNR1206TS	LNR1208TS	LNR1210TS	LNR1212TS	LNR1216TS	LNR1225TS
16 mm	LNR1601TS	LNR1602TS	LNR1604TS	LNR1605TS	LNR1606TS	LNR1608TS	LNR1610TS	LNR1612TS	LNR1616TS	LNR1625TS

Screw Diameter	Inch Leads • Part Numbers	
	Lead	Standard
3/16"	0.05"	LNR18005TS
	0.50"	LNR18050TS
1/4"	0.333"	LNR25033TS
3/8"	0.20"	LNR37020TS
7/16"	1.00"	LNR43100TS
1/2"	0.10"	LNR50010TS
	0.25"	LNR50025TS

Triangle Constant Force Anti-Backlash Nut

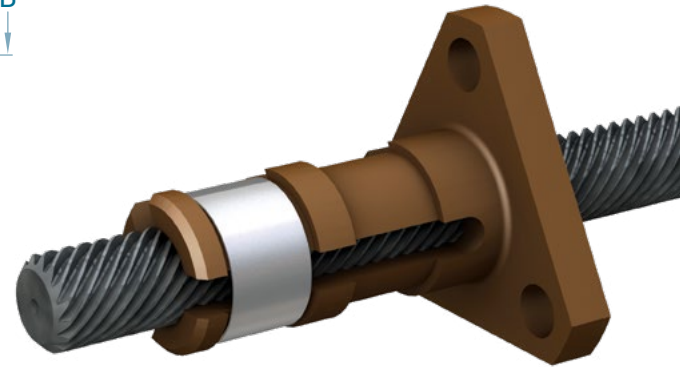
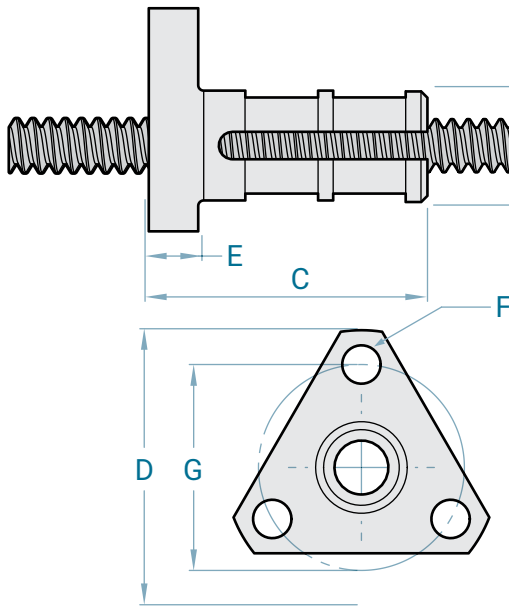

	A	B	C	D	E	F	G	Drag Torque** (Nm)	Dynamic Load (N)
	Screw Diameter	Nut Dia. (mm)	Nut Length (mm)	Flange Dia. (mm)	Flange Thickness (mm)	Mounting Hole Dia. (mm)	Bolt Circle Dia. (mm)		
Metric Screws	6 mm	10.2	22.2	25.4	4.1	3.6	19.1	.0134-.0164	302 N
	10 mm	15.9	38.1	38.1	4.8	5.1	28.6	.0197-.0240	400 N
	12 mm	16.9	44.5	44.5	6.4	5.6	35.7	.0211-.0264	703 N
	16 mm	20.3	49.5	54.0	6.4	5.6	44.5	.0250-.0310	1,040 N
	A	B	C	D	E	F	G	Drag Torque** (oz-in)	Dynamic Load (lb)
	Screw Diameter	Nut Dia. (in)	Nut Length (in)	Flange Dia. (in)	Flange Thickness (in)	Mounting Hole Dia. (in)	Bolt Circle Dia. (in)		
Inch Screws	3/16"	0.35	0.88	0.81	0.13	0.12	0.600	1.45-1.88	41
	1/4"	0.41	0.88	1.00	0.19	0.14	0.750	2.37-2.90	68
	3/8"	0.61	1.50	1.50	0.19	0.20	1.125	3.00-3.84	77
	7/16"	0.64	1.62	1.62	0.22	0.20	1.250	3.60-4.40	112
	1/2"	0.69	1.75	1.75	0.25	0.22	1.406	4.00-5.00	180

Leads	Metric Diameters • Part Numbers			
	6 mm	10 mm	12 mm	16 mm
1 mm	LNR0601TCF-ASY	LNR1001TCF-ASY	LNR1201TCF-ASY	LNR1601TCF-ASY
2 mm	LNR0602TCF-ASY	LNR1002TCF-ASY	LNR1202TCF-ASY	LNR1602TCF-ASY
4 mm	LNR0604TCF-ASY	LNR1004TCF-ASY	LNR1204TCF-ASY	LNR1604TCF-ASY
5 mm	LNR0605TCF-ASY	LNR1005TCF-ASY	LNR1205TCF-ASY	LNR1605TCF-ASY
6 mm	LNR0606TCF-ASY	LNR1006TCF-ASY	LNR1206TCF-ASY	LNR1606TCF-ASY
8 mm	LNR0608TCF-ASY	LNR1008TCF-ASY	LNR1208TCF-ASY	LNR1608TCF-ASY
10 mm	LNR0610TCF-ASY	LNR1010TCF-ASY	LNR1210TCF-ASY	LNR1610TCF-ASY
12 mm	LNR0612TCF-ASY	LNR1012TCF-ASY	LNR1212TCF-ASY	LNR1612TCF-ASY
16 mm	-	LNR1016TCF-ASY	LNR1216TCF-ASY	LNR1616TCF-ASY
25 mm	-	LNR1025TCF-ASY	LNR1225TCF-ASY	LNR1625TCF-ASY

Screw Diameter	Inch Part Numbers	
	Lead	Constant Force
3/16"	0.05"	LNR18005TCF
	0.50"	LNR18050TCF
1/4"	0.333"	LNR25033TCF
3/8"	0.20"	LNR37020TCF
7/16"	1.00"	LNR43100TCF
1/2"	0.10"	LNR50010TCF
	0.25"	LNR50025TCF

* Nut will have between 1 to 3 band slots. Band slots may not contain bands depending on drag torque required.

** Standard drag torque is factory set to the median number shown. For custom drag torque please contact a PBC Linear Applications Engineer.

Round Nut Standard

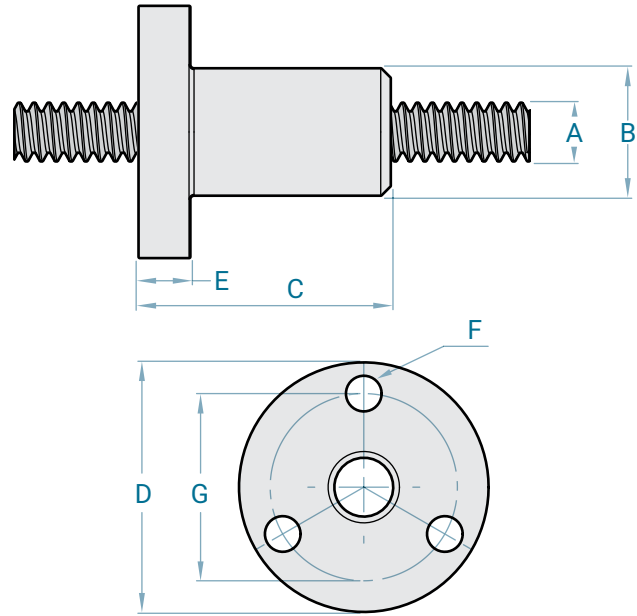
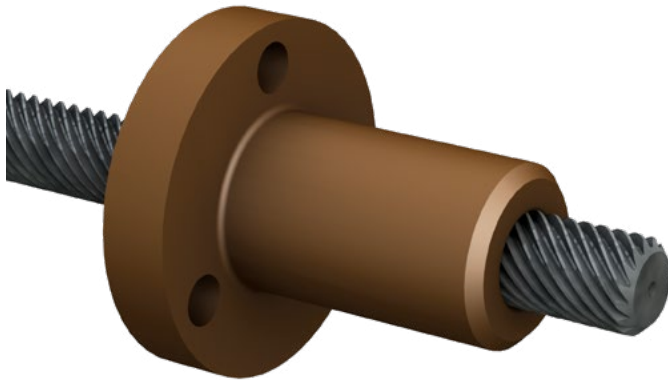

Metric Screws	A	B	C	D	E	F	G	Drag Torque (Nm)	Dynamic Load (N)		
	Screw Dia. (mm)	Nut Dia. (mm)	Nut Length (mm)	Flange Dia. (mm)	Flange Thickness (mm)	Mounting Hole Dia. (mm)	Bolt Circle Dia. (mm)				
	6 mm	10.2	22.2	25.4	4.8	3.6	19.1			Free Wheeling	334 N
	10 mm	15.9	25.4	38.1	4.8	5.1	28.6			Free Wheeling	445 N
	12 mm	16.9	38.1	44.5	6.4	5.6	35.7			Free Wheeling	778 N
16 mm	20.3	38.1	54.0	6.4	5.6	44.5	Free Wheeling	1,160 N			

Inch Screws	A	B	C	D	E	F	G	Drag Torque (oz-in)	Dynamic Load (lb)		
	Screw Diameter	Nut Dia. (in)	Nut Length (in)	Flange Dia. (in)	Flange Thickness (in)	Mounting Hole Dia. (in)	Bolt Circle Dia. (in)				
	3/16"	0.35	0.63	0.81	0.13	0.12	0.600			Free Wheeling	45
	1/4"	0.41	0.88	1.00	0.19	0.14	0.750			Free Wheeling	75
	3/8"	0.61	1.00	1.50	0.19	0.20	1.125			Free Wheeling	85
7/16"	0.64	1.50	1.62	0.22	0.20	1.250	Free Wheeling	125			
1/2"	0.69	1.50	1.75	0.25	0.22	1.406	Free Wheeling	200			

Screw Diameter	Metric Leads • Part Numbers									
	1 mm	2 mm	4 mm	5 mm	6 mm	8 mm	10 mm	12 mm	16 mm	25 mm
6 mm	LNR0601RS	LNR0602RS	LNR0604RS	LNR0605RS	LNR0606RS	LNR0608RS	LNR0610RS	LNR0612RS	-	-
10 mm	LNR1001RS	LNR1002RS	LNR1004RS	LNR1005RS	LNR1006RS	LNR1008RS	LNR1010RS	LNR1012RS	LNR1016RS	LNR1025RS
12 mm	LNR1201RS	LNR1202RS	LNR1204RS	LNR1205RS	LNR1206RS	LNR1208RS	LNR1210RS	LNR1212RS	LNR1216RS	LNR1225RS
16 mm	LNR1601RS	LNR1602RS	LNR1604RS	LNR1605RS	LNR1606RS	LNR1608RS	LNR1610RS	LNR1612RS	LNR1616RS	LNR1625RS

Screw Diameter	Inch Leads • Part Numbers	
	Lead	Standard
3/16"	0.05"	LNR18005RS
	0.50"	LNR18050RS
1/4"	0.333"	LNR25033RS
3/8"	0.20"	LNR37020RS
7/16"	1.00"	LNR43100RS
1/2"	0.10"	LNR50010RS
	0.25"	LNR50025RS

Round Constant Force Anti-Backlash Nut

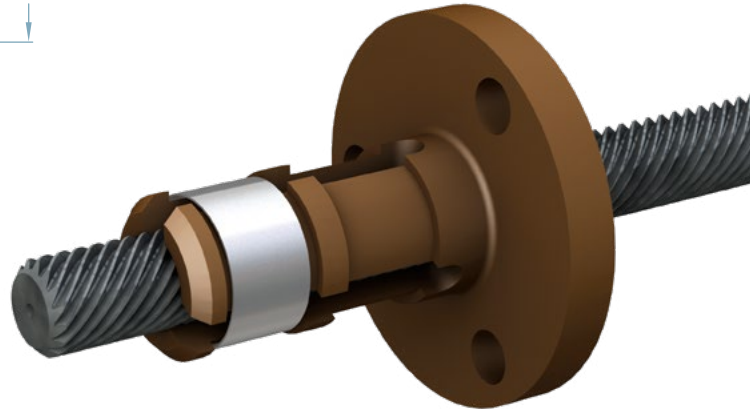
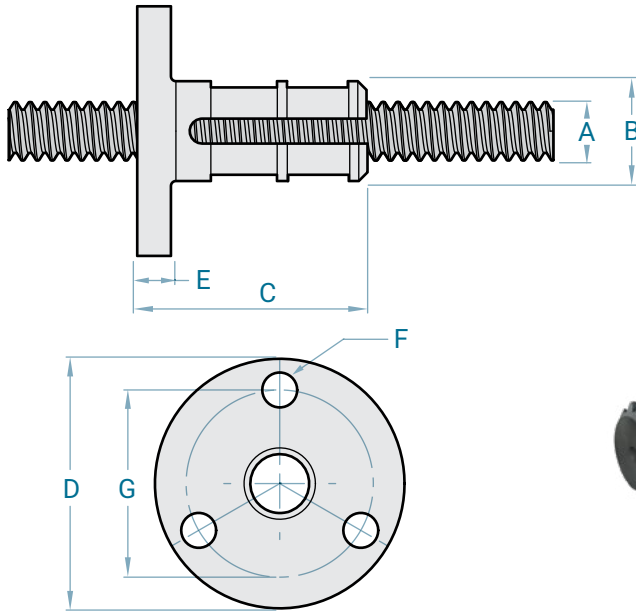

	A	B	C	D	E	F	G		
Metric Screws	Screw Diameter	Nut Dia. (mm)	Nut Length (mm)	Flange Dia. (mm)	Flange Thickness (mm)	Mounting Hole Dia. (mm)	Bolt Circle Dia. (mm)	Drag Torque** (Nm)	Dynamic Load (N)
	6 mm	10.2	22.2	25.4	4.8	3.6	19.1	.0134-.0164	302 N
	10 mm	15.9	38.1	38.1	4.8	5.1	28.6	.0197-.0240	400 N
	12 mm	16.9	44.5	44.5	6.4	5.6	35.7	.0211-.0264	703 N
	16 mm	20.3	49.5	54.0	6.4	5.6	44.5	.0250-.0310	1,040 N

	A	B	C	D	E	F	G		
Inch Screws	Screw Diameter	Nut Dia. (in)	Nut Length (in)	Flange Dia. (in)	Flange Thickness (in)	Mounting Hole Dia. (in)	Bolt Circle Dia. (in)	Drag Torque** (oz-in)	Dynamic Load (lb)
	3/16"	0.35	0.88	0.81	0.13	0.12	0.600	1.45-1.88	41
	1/4"	0.41	0.88	1.00	0.19	0.14	0.750	2.37-2.90	68
	3/8"	0.61	1.50	1.50	0.19	0.20	1.125	3.00-3.84	77
	7/16"	0.64	1.62	1.62	0.22	0.20	1.250	3.60-4.40	112
1/2"	0.69	1.75	1.75	0.25	0.22	1.406	4.00-5.00	180	

Leads	Metric Diameters • Part Numbers			
	6 mm	10 mm	12 mm	16 mm
1 mm	LNR0601RCF-ASY	LNR1001RCF-ASY	LNR1201RCF-ASY	LNR1601RCF-ASY
2 mm	LNR0602RCF-ASY	LNR1002RCF-ASY	LNR1202RCF-ASY	LNR1602RCF-ASY
4 mm	LNR0604RCF-ASY	LNR1004RCF-ASY	LNR1204RCF-ASY	LNR1604RCF-ASY
5 mm	LNR0605RCF-ASY	LNR1005RCF-ASY	LNR1205RCF-ASY	LNR1605RCF-ASY
6 mm	LNR0606RCF-ASY	LNR1006RCF-ASY	LNR1206RCF-ASY	LNR1606RCF-ASY
8 mm	LNR0608RCF-ASY	LNR1008RCF-ASY	LNR1208RCF-ASY	LNR1608RCF-ASY
10 mm	LNR0610RCF-ASY	LNR1010RCF-ASY	LNR1210RCF-ASY	LNR1610RCF-ASY
12 mm	LNR0612RCF-ASY	LNR1012RCF-ASY	LNR1212RCF-ASY	LNR1612RCF-ASY
16 mm	-	LNR1016RCF-ASY	LNR1216RCF-ASY	LNR1616RCF-ASY
25 mm	-	LNR1025RCF-ASY	LNR1225RCF-ASY	LNR1625RCF-ASY

Screw Diameter	Inch Part Numbers	
	Lead	Constant Force
3/16"	0.05"	LNR18005RCF
	0.50"	LNR18050RCF
1/4"	0.333"	LNR25033RCF
3/8"	0.20"	LNR37020RCF
7/16"	1.00"	LNR43100RCF
1/2"	0.10"	LNR50010RCF
	0.25"	LNR50025RCF

* Nut will have between 1 to 3 band slots. Band slots may not contain bands depending on drag torque required.

** Standard drag torque is factory set to the median number shown. For custom drag torque please contact a PBC Linear Applications Engineer.

Threaded Nut Standard

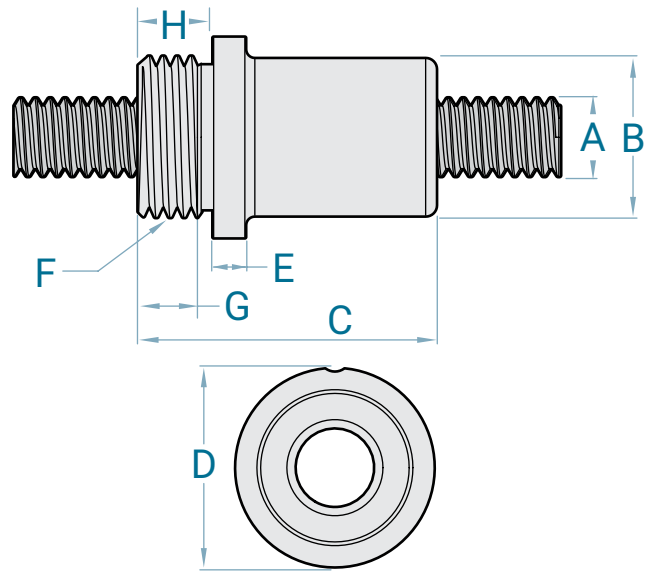
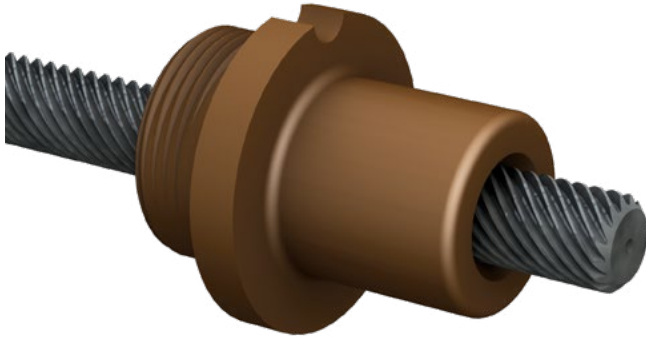

Metric Screws	A	B	C	D	E	F	G	H	Drag Torque (Nm)	Dynamic Load (N)		
	Screw Diameter	Nut Dia. (mm)	Nut Length (mm)	Flange Dia. (mm)	Flange Thickness (mm)	Thread	Thread Length (mm)	End Length (mm)				
	6 mm	10.2	22.2	20.3	3.2	M14x1.5	4.8	4.8			Free Wheeling	334 N
	10 mm	15.9	25.4	25.4	3.2	M18x1.5	6.4	7.6			Free Wheeling	445 N
	12 mm	16.9	38.1	31.8	3.2	M24x2	9.5	10.8			Free Wheeling	778 N
16 mm	20.3	38.1	31.8	3.2	M24x2	9.5	10.8	Free Wheeling	1,160 N			

Inch Screws	A	B	C	D	E	F	G	H	Drag Torque (oz-in)	Dynamic Load (lb)		
	Screw Diameter	Nut Dia. (in)	Nut Length (in)	Flange Dia. (in)	Flange Thickness (in)	Thread	Thread Length (mm)	End Length (mm)				
	3/16"	0.35	0.88	0.60	0.13	1/2"-20	0.190	0.247			Free Wheeling	45
	1/4"	0.41	0.88	0.80	0.13	9/16"-18	0.190	0.247			Free Wheeling	75
	3/8"	0.61	1.00	1.00	0.13	5/8"-18	0.250	0.300			Free Wheeling	85
7/16"	0.64	1.50	1.25	0.13	13/16"-16	0.375	0.425	Free Wheeling	125			
1/2"	0.69	1.50	1.25	0.13	15/16"-16	0.375	0.425	Free Wheeling	200			

Screw Diameter	Metric Leads • Part Numbers									
	1 mm	2 mm	4 mm	5 mm	6 mm	8 mm	10 mm	12 mm	16 mm	25 mm
6 mm	LNR0601US	LNR0602US	LNR0604US	LNR0605US	LNR0606US	LNR0608US	LNR0610US	LNR0612US	-	-
10 mm	LNR1001US	LNR1002US	LNR1004US	LNR1005US	LNR1006US	LNR1008US	LNR1010US	LNR1012US	LNR1016US	LNR1025US
12 mm	LNR1201US	LNR1202US	LNR1204US	LNR1205US	LNR1206US	LNR1208US	LNR1210US	LNR1212US	LNR1216US	LNR1225US
16 mm	LNR1601US	LNR1602US	LNR1604US	LNR1605US	LNR1606US	LNR1608US	LNR1610US	LNR1612US	LNR1616US	LNR1625US

Screw Diameter	Inch Leads • Part Numbers	
	Lead	Standard
3/16"	0.05"	LNR18005US
	0.50"	LNR18050US
1/4"	0.333"	LNR25033US
3/8"	0.20"	LNR37020US
7/16"	1.00"	LNR43100US
1/2"	0.10"	LNR50010US
	0.25"	LNR50025US

Threaded Constant Force Anti-Backlash Nut

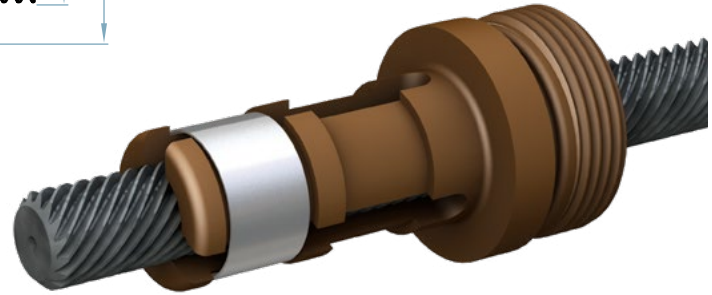
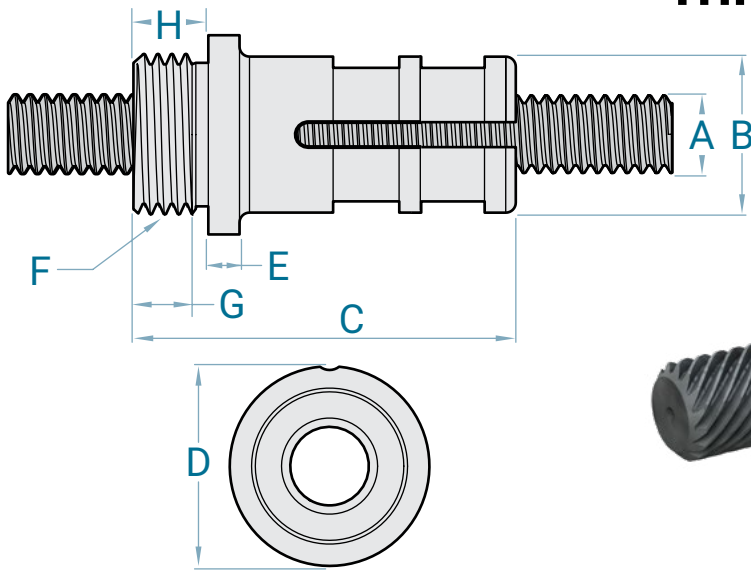

Metric Screws	A	B	C	D	E	F	G	H	Drag Torque** (Nm)	Dynamic Load (N)		
	Screw Diameter	Nut Dia. (mm)	Nut Length (mm)	Flange Dia. (mm)	Flange Thickness (mm)	Thread	Thread Length (mm)	End Length (mm)				
	6 mm	10.2	27.5	20.3	3.175	M14x1.5	4.8	4.8			0.0134-0.0164	302 N
	10 mm	15.9	44.5	25.4	3.175	M18x1.5	6.4	7.6			0.0197-0.0240	400 N
	12 mm	16.9	44.5	31.8	3.175	M24X2	9.5	10.8			0.0211-0.0264	703 N
16 mm	20.3	49.5	31.8	3.175	M24x2	9.5	10.8	0.0250-0.0310	1,040 N			

Inch Screws	A	B	C	D	E	F	G	H	Drag Torque** (oz-in)	Dynamic Load (lb)		
	Screw Diameter	Nut Dia. (in)	Nut Length (in)	Flange Dia. (in)	Flange Thickness (in)	Thread	Thread Length (mm)	End Length (in)				
	3/16"	0.35	1.08	0.60	0.13	1/2"-20	0.190	0.247			1.45-1.88	41
	1/4"	0.41	1.08	0.80	0.13	9/16"-18	0.190	0.247			2.37-2.90	68
	3/8"	0.61	1.75	1.00	0.13	5/8"-18	0.250	0.300			3.00-3.84	77
7/16"	0.64	1.75	1.25	0.13	13/16"-16	0.375	0.425	3.60-4.40	112			
1/2"	0.69	1.95	1.25	0.13	15/16"-16	0.375	0.425	4.00-5.00	180			

Leads	Metric Diameters • Part Numbers			
	6 mm	10 mm	12 mm	16 mm
1 mm	LNR0601UCF-ASY	LNR1001UCF-ASY	LNR1201UCF-ASY	LNR1601UCF-ASY
2 mm	LNR0602UCF-ASY	LNR1002UCF-ASY	LNR1202UCF-ASY	LNR1602UCF-ASY
4 mm	LNR0604UCF-ASY	LNR1004UCF-ASY	LNR1204UCF-ASY	LNR1604UCF-ASY
5 mm	LNR0605UCF-ASY	LNR1005UCF-ASY	LNR1205UCF-ASY	LNR1605UCF-ASY
6 mm	LNR0606UCF-ASY	LNR1006UCF-ASY	LNR1206UCF-ASY	LNR1606UCF-ASY
8 mm	LNR0608UCF-ASY	LNR1008UCF-ASY	LNR1208UCF-ASY	LNR1608UCF-ASY
10 mm	LNR0610UCF-ASY	LNR1010UCF-ASY	LNR1210UCF-ASY	LNR1610UCF-ASY
12 mm	LNR0612UCF-ASY	LNR1012UCF-ASY	LNR1212UCF-ASY	LNR1612UCF-ASY
16 mm	-	LNR1016UCF-ASY	LNR1216UCF-ASY	LNR1616UCF-ASY
25 mm	-	LNR1025UCF-ASY	LNR1225UCF-ASY	LNR1625UCF-ASY

Screw Diameter	Inch Part Numbers	
	Lead	Constant Force
3/16"	0.05"	LNR18005UCF
	0.50"	LNR18050UCF
1/4"	0.333"	LNR25033UCF
3/8"	0.20"	LNR37020UCF
7/16"	1.00"	LNR43100UCF
1/2"	0.10"	LNR50010UCF
	0.25"	LNR50025UCF

* Nut will have between 1 to 3 band slots. Band slots may not contain bands depending on drag torque required.

** Standard drag torque is factory set to the median number shown. For custom drag torque please contact a PBC Linear Applications Engineer.

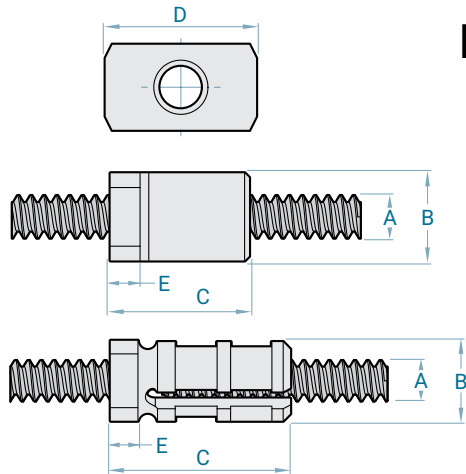

Rectangle Standard

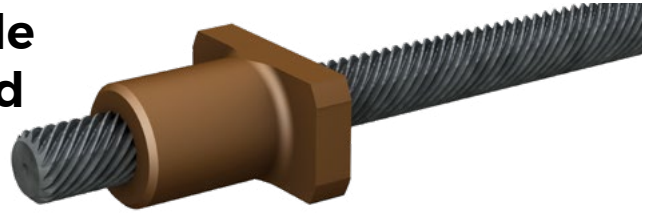

Constant Force Anti-Backlash Nut

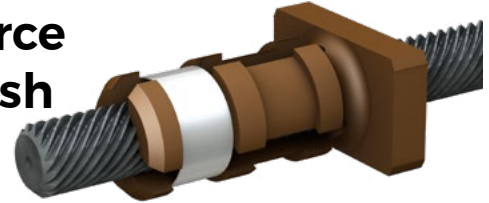

Metric Screws	A	B		C		D	E	Drag Torque** (Nm)		Dynamic Load (N)	
	Screw Diameter	Nut Dia. (mm)		Nut Length (mm)		Flange Dia. (mm)	Flange Thickness (mm)	Standard	Constant Force	Standard	Constant Force
		Standard	Constant Force	Standard	Constant Force	Both	Both				
	6 mm	10.2	10.2	22.2	22.2	17.8	3.4	Free Wheeling	.0134-.0164	334 N	302 N
	10 mm	15.9	15.9	25.4	38.1	22.0	5.1	Free Wheeling	.0197-.0240	445 N	400 N
	12 mm	16.9	16.9	38.1	41.3	30.5	5.1	Free Wheeling	.0211-.0264	778 N	703 N
	16 mm	20.3	20.3	38.1	49.5	38.1	5.1	Free Wheeling	.0250-.0310	1,160 N	1,040 N

Inch Screws	A	B		C		D	E	Drag Torque** (oz-in)		Dynamic Load (lb)	
	Screw Diameter	Nut Dia. (in)		Nut Length (in)		Flange Dia. (in)	Flange Thickness (in)	Standard	Constant Force	Standard	Constant Force
		Standard	Constant Force	Standard	Constant Force	Both	Both				
	3/16"	0.35	0.35	0.63	0.88	0.62	0.09	Free Wheeling	1.45-1.88	45	41
	1/4"	0.41	0.41	0.88	0.88	0.70	0.14	Free Wheeling	2.37-2.90	75	68
	3/8"	0.61	0.61	1.00	1.50	0.87	0.20	Free Wheeling	3.00-3.84	85	77
	7/16"	0.64	0.64	1.30	1.63	1.20	0.20	Free Wheeling	3.60-4.40	125	112
	1/2"	0.69	0.69	1.50	1.75	1.20	0.20	Free Wheeling	4.00-5.00	200	180

Leads		Metric Diameters - Part Numbers			
		6 mm	10 mm	12 mm	16 mm
1 mm	Standard	LNR0601VS	LNR1001VS	LNR1201VS	LNR1601VS
	Constant Force	LNR0601VCF-ASY	LNR1001VCF-ASY	LNR1201VCF-ASY	LNR1601VCF-ASY
2 mm	Standard	LNR0602VS	LNR1002VS	LNR1202VS	LNR1602VS
	Constant Force	LNR0602VCF-ASY	LNR1002VCF-ASY	LNR1202VCF-ASY	LNR1602VCF-ASY
4 mm	Standard	LNR0604VS	LNR1004VS	LNR1204VS	LNR1604VS
	Constant Force	LNR0604VCF-ASY	LNR1004VCF-ASY	LNR1204VCF-ASY	LNR1604VCF-ASY
5 mm	Standard	LNR0605VS	LNR1005VS	LNR1205VS	LNR1605VS
	Constant Force	LNR0605VCF-ASY	LNR1005VCF-ASY	LNR1205VCF-ASY	LNR1605VCF-ASY
6 mm	Standard	LNR0606VS	LNR1006VS	LNR1206VS	LNR1606VS
	Constant Force	LNR0606VCF-ASY	LNR1006VCF-ASY	LNR1206VCF-ASY	LNR1606VCF-ASY
8 mm	Standard	LNR0608VS	LNR1008VS	LNR1208VS	LNR1608VS
	Constant Force	LNR0608VCF-ASY	LNR1008VCF-ASY	LNR1208VCF-ASY	LNR1608VCF-ASY
10 mm	Standard	LNR0610VS	LNR1010VS	LNR1210VS	LNR1610VS
	Constant Force	LNR0610VCF-ASY	LNR1010VCF-ASY	LNR1210VCF-ASY	LNR1610VCF-ASY
12 mm	Standard	LNR0612VS	LNR1012VS	LNR1212VS	LNR1612VS
	Constant Force	LNR0612VCF-ASY	LNR1012VCF-ASY	LNR1212VCF-ASY	LNR1612VCF-ASY
16 mm	Standard	-	LNR1016VS	LNR1216VS	LNR1616VS
	Constant Force	-	LNR1016VCF-ASY	LNR1216VCF-ASY	LNR1616VCF-ASY
25 mm	Standard	-	LNR1025VS	LNR1225VS	LNR1625VS
	Constant Force	-	LNR1025VCF-ASY	LNR1225VCF-ASY	LNR1625VCF-ASY

Screw Diameter	Inch Part Numbers		
	Lead	Standard	Constant Force
3/16"	0.05"	LNR18005VS	LNR18005VCF
	0.50"	LNR18050VS	LNR18050VCF
1/4"	0.333"	LNR25033VS	LNR25033VCF
3/8"	0.20"	LNR37020VS	LNR37020VCF
7/16"	1.00"	LNR43100VS	LNR43100VCF
1/2"	0.10"	LNR50010VS	LNR50010VCF
	0.25"	LNR50025VS	LNR50025VCF

* Nut will have between 1 to 3 band slots. Band slots may not contain bands depending on drag torque required.

** Standard drag torque is factory set to the median number shown. For custom drag torque please contact a PBC Linear Applications Engineer.

Machined Ends

Float Journal AFN, AFB

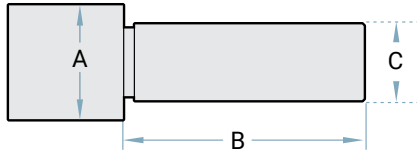

Threaded Journalled THR



Fixed Journalled ALN, ALB

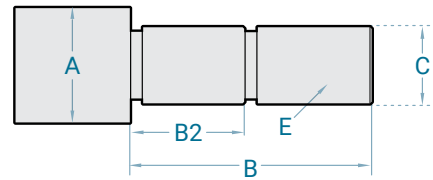
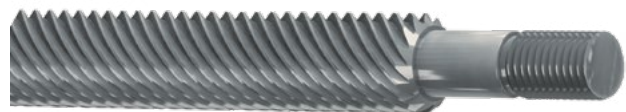

	A	B		C	
		Float	Threaded	Float	Threaded
Metric Screws	6 mm	15.24 mm	20.00 mm	4.98 mm	M5 x 0.80-6g
	10 mm	15.75 mm	20.00 mm	5.97 mm	M6 x 1.00-6g
	12 mm	20.32 mm	25.00 mm	9.98 mm	M10 x 1.50-6g
	16 mm	21.34 mm	25.00 mm	11.97 mm	M12 x 1.75-6g
Inch Screws	3/16"	0.600"	0.787"	0.157"	M4 x 0.70-6g
	1/4"	0.600"	0.787"	0.197"	M5 x 0.80-6g
	3/8"	0.600"	0.787"	0.235"	M6 x 1.00-6g
	7/16"	0.800"	0.984"	0.393"	M10 x 1.50-6g
	1/2"	0.800"	0.984"	0.393"	M10 x 1.50-6g

	A	B	B2	C	E
	Metric Screws	6 mm	22.86 mm	10.00 mm	4.98 mm
	10 mm	22.86 mm	9.00 mm	5.97 mm	M6 x 1.00-6g
	12 mm	33.27 mm	14.22 mm	9.97 mm	M10 x 1.50-6g
	16 mm	36.88 mm	15.90 mm	11.97 mm	M12 x 1.75-6g
Inch Screws	3/16"	0.900"	0.315"	0.157"	M4 x 0.70-6g
	1/4"	0.900"	0.394"	0.196"	M5 x 0.80-6g
	3/8"	0.900"	0.354"	0.235"	M6 x 1.00-6g
	7/16"	1.310"	0.560"	0.393"	M10 x 1.50-6g
	1/2"	1.310"	0.560"	0.393"	M10 x 1.50-6g

Float with Journalled End BFN, BFB

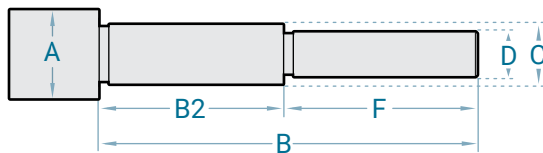

	A	B	B2	C	D	F
	Metric Screws	6 mm	25.40 mm	15.24 mm	4.98 mm	4.00 mm
10 mm		30.86 mm	15.24 mm	5.97 mm	4.00 mm	15.62 mm
12 mm		36.32 mm	20.32 mm	9.97 mm	8.00 mm	16.00 mm
16 mm		37.08 mm	20.70 mm	11.97 mm	10.00 mm	16.38 mm
Inch Screws	3/16"	1.000"	0.600"	0.157"	0.125"	0.400"
	1/4"	1.000"	0.600"	0.197"	0.125"	0.400"
	3/8"	1.215"	0.600"	0.235"	0.188"	0.615"
	7/16"	1.430"	0.800"	0.393"	0.313"	0.630"
	1/2"	1.430"	0.800"	0.393"	0.313"	0.630"

Fixed with Journalled End BLN, BLB

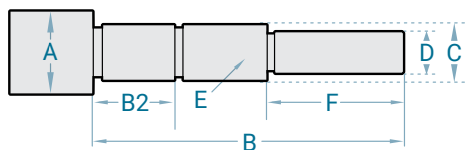

	A	B	B2	C	D	E	F
	Metric Screws	6 mm	34.85 mm	10.00 mm	4.98 mm	4.00 mm	M5 x 0.80-6g
10 mm		38.10 mm	9.00 mm	5.97 mm	4.00 mm	M6 x 1.00-6g	15.24 mm
12 mm		48.90 mm	14.22 mm	9.97 mm	8.00 mm	M10 x 1.50-6g	16.00 mm
16 mm		50.80 mm	15.90 mm	11.97 mm	10.00 mm	M12 x 1.75-6g	16.54 mm
Inch Screws	3/16"	1.372"	0.315"	0.157"	0.125"	M4 x 0.70-6g	0.487
	1/4"	1.372"	0.394"	0.197"	0.125"	M5 x 0.80-6g	0.487"
	3/8"	1.500"	0.354"	0.235"	0.188"	M6 x 1.00-6g	0.600"
	7/16"	1.926"	0.560"	0.393"	0.313"	M10 x 1.50-6g	0.630"
	1/2"	1.926"	0.560"	0.393"	0.313"	M10 x 1.50-6g	0.630"

Machined Ends

Float Journal with Flat CFN, CFB

(for 6 mm, 10 mm, 3/16", 1/4", 3/8" screws)

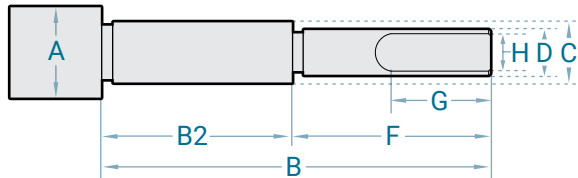

Float Journal with Keyway CFN, CFB

(for 12 mm, 16 mm, 7/16", 1/2" screws)

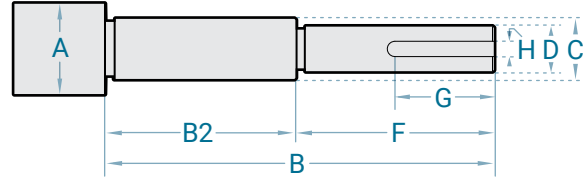

	A	B	B2	C	D	F	G	H
Metric Screws	6 mm	25.40 mm	15.24 mm	4.98 mm	4.00 mm	10.16 mm	7.26 mm	Flat
	10 mm	30.86 mm	15.24 mm	5.97 mm	4.00 mm	15.62 mm	9.53 mm	Flat
	12 mm	36.32 mm	20.32 mm	9.97 mm	8.00 mm	16.00 mm	12.70 mm	3 mm Keyway
	16 mm	37.08 mm	20.70 mm	11.97 mm	10.00 mm	16.38 mm	12.70 mm	3 mm Keyway
Inch Screws	3/16"	1.000"	0.600"	0.157"	0.125"	0.400"	0.286"	Flat
	1/4"	1.000"	0.600"	0.197"	0.125"	0.400"	0.286"	Flat
	3/8"	1.215"	0.600"	0.235"	0.188"	0.615"	0.375"	Flat
	7/16"	1.430"	0.800"	0.393"	0.313"	0.630"	0.500"	0.125" Keyway
	1/2"	1.430"	0.800"	0.393"	0.313"	0.630"	0.500"	0.125" Keyway

Fixed Journal with Flat CLN, CLB

(for 6 mm, 10 mm, 3/16", 1/4", 3/8" screws)

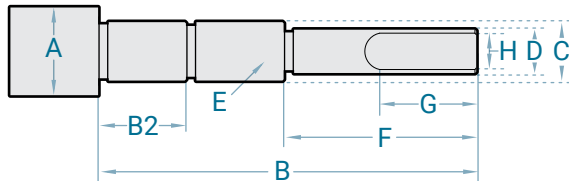

Fixed Journal with Keyway CLN, CLB

(for 12 mm, 16 mm, 7/16", 1/2" screws)

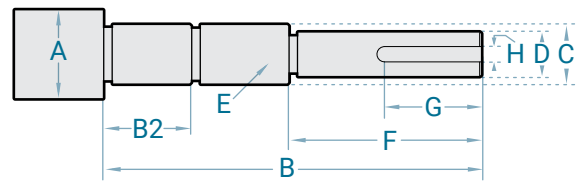

	A	B	B2	C	D	E	F	G	H
Metric Screws	6 mm	34.85 mm	10.00 mm	4.98 mm	4.00 mm	M5 x 0.80-6g	12.37mm	7.26 mm	Flat
	10 mm	38.10 mm	9.00 mm	5.97 mm	4.00 mm	M6 x 1.00-6g	15.24 mm	9.53 mm	Flat
	12 mm	48.90 mm	14.22 mm	9.97 mm	8.00 mm	M10 x 1.50-6g	16.00 mm	12.70 mm	3 mm Keyway
	16 mm	50.80 mm	15.90 mm	11.97 mm	10.00 mm	M12 x 1.75-6g	16.54 mm	12.70 mm	3 mm Keyway
Inch Screws	3/16"	1.372"	0.315"	0.157"	0.125"	M4 x 0.70-6g	0.487"	0.286"	Flat
	1/4"	1.372"	0.394"	0.197"	0.125"	M5 x 0.80-6g	0.487"	0.286"	Flat
	3/8"	1.500"	0.354"	0.235"	0.188"	M6 x 1.00-6g	0.600"	0.375"	Flat
	7/16"	1.925"	0.560"	0.393"	0.313"	M10 x 1.50-6g	0.630"	0.500"	0.125" Keyway
	1/2"	1.925"	0.560"	0.393"	0.313"	M10 x 1.50-6g	0.630"	0.500"	0.125" Keyway

Bearing Supports

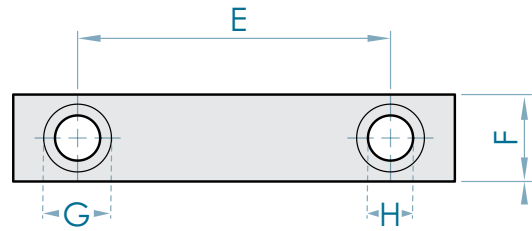
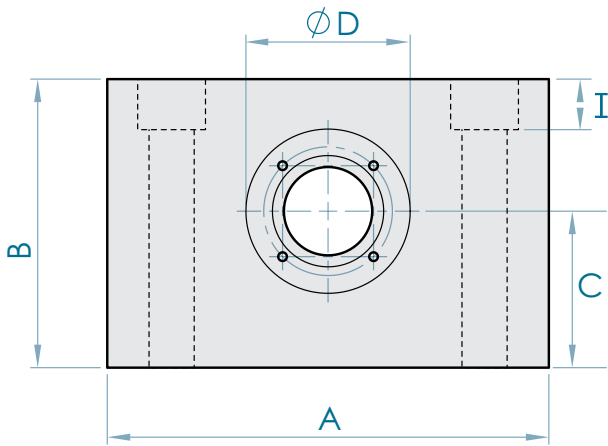
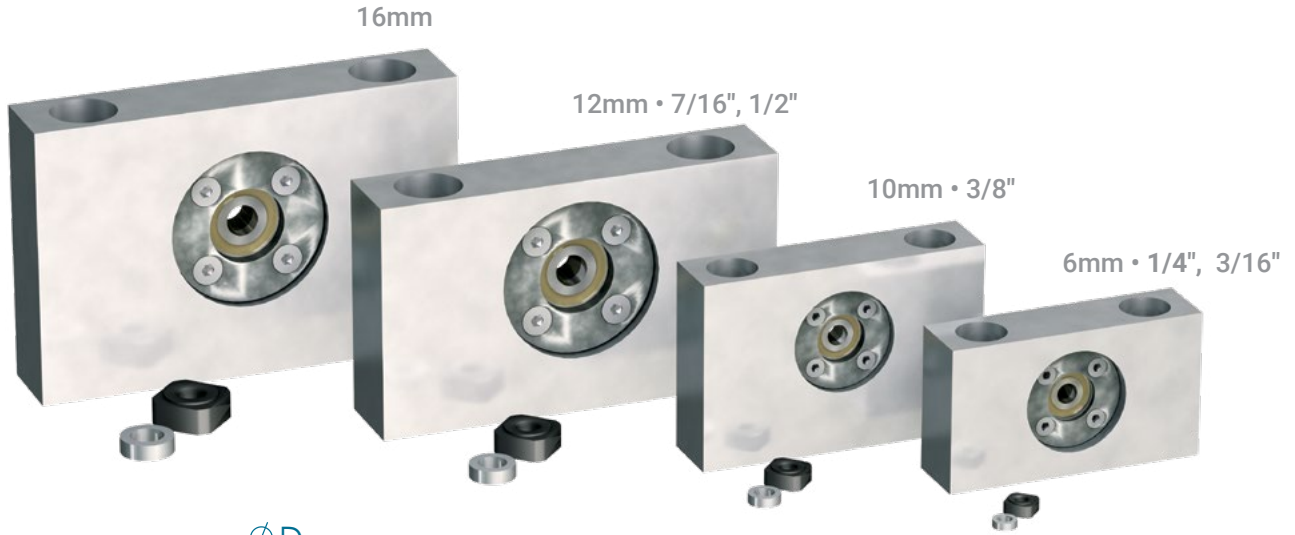

	For Screw Dia.	Fixed P/N	A	B	C	D	E	F	G	H*	I
			mm	mm	mm	mm	mm	mm	C'Bore Dia mm	Internal mm	C'Bore Depth mm
Metric Screws	6 mm	LSFEB-06	76	43	22	30.25	50.0	20	14.5	8.8	8
	10 mm	LSFEB-10	85	56	33	30.25	60.0	20	14.5	8.8	8
	12 mm	LSFEB-12	120	70	40	47.25	82.5	25	19.5	13.0	12
	16 mm	LSFEB-16	127	83	45	47.25	90.0	25	19.5	13.0	12
Inch Screws	3/16"	LSFEB-05	76	43	22	30.25	50.0	20	14.5	8.8	8
	1/4"	LSFEB-06	76	43	22	30.25	50.0	20	14.5	8.8	8
	3/8"	LSFEB-10	85	56	33	30.25	60.0	20	14.5	8.8	8
	7/16"	LSFEB-12	120	70	40	47.25	82.5	25	19.5	13.0	12
	1/2"	LSFEB-12	120	70	40	47.25	82.5	25	19.5	13.0	12

* Recommended metric screws for 16 mm and 12 mm block mounting holes is the Socket head cap screw of M12-1.75 and for 10 mm and 06 mm is the of M8-1.25

Note: Contact factory for custom size options.

Lead Screw Motors



Why use a PBC Linear Lead Screw Motor?

Cost reduction

Fusing the motor and screw together eliminates the need for a motor mount and coupling. This also reduces setup time.

Improved performance

Factor alignment of the motor and screw means direct out of the box precision.

Variety

Many choices of nut styles and technologies including Constant Force, to cover almost every application need. Multiple standard machining and plating choices helps get what is needed quickly and easily.

Support & Customs

Not finding what you need or need a custom solution? PBC Linear has your engineering support covered! Phone: 1-888-389-6266 or pbc_applicationsengineering@pbclinear.com

PBC Linear lead screw motor products are designed based on the know-how technology of hybrid step motors, lead screw and nuts. The NEMA Series lead screw motors provide high torque, high precision, and high efficiency to fit the application needs of designers. The combination of lead screw motor styles, sizes, lead-screws and nuts, gives the freedom to use motors of different form factors to exactly fit in the application. And, it provides the best performance with any drive and power supply.

- Four frame Sizes: 11, 14, 17, 23
- Multiple motor lengths and special PowerPlus motors, provide more than 10 different motor sizes
- Integrate any lead screw from PBC Linear
- Each frame size motor has 3-11 different standard lead screws
- Each frame size motor has different selections of nuts

PBC Linear has committed to product innovation design and technical improvement, with excellent product quality, application technology, fast and flexible services, which provide customers with high level motion control solutions.

Hybrid Linear Lead Screw Actuator Selection Chart

Motor Frame	Screw Sizes								
	3/16"	6 mm	1/4"	3/8"	10 mm	7/16"	12 mm	1/2"	16 mm
NEMA 8	•	•	•						
NEMA 11	•	•	•						
NEMA 14	•	•	•	•	•				
NEMA 17, Single Stack		•	•	•	•	•	•	•	
NEMA 17, Double Stack				•	•	•	•	•	
NEMA 23, Single Stack				•	•	•	•	•	•
NEMA 23, Double Stack				•	•	•	•	•	•
NEMA 23, Power Plus				•	•	•	•	•	•

Lead Screw to Motor Connection Method Matters

Traditional Motor/Screw Setup

- Multiple components that require assembly
- Difficult to align
- Play and tolerance between components result in lost accuracy
- Increased potential for failure
- Higher costs

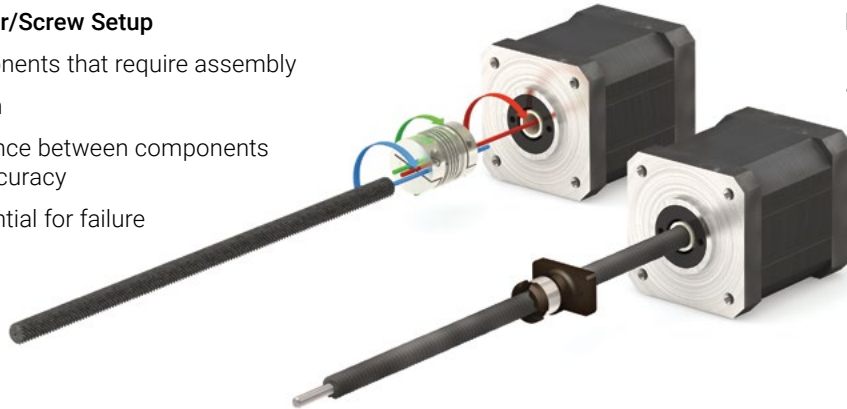

Integrated Hybrid Linear Actuator Setup

- Lead screw aligned and fixed directly with motor
- Fewer components
- Greater accuracy
- More reliable
- Higher rigidity
- Greater value

Common Lead Screw Straightness Issues

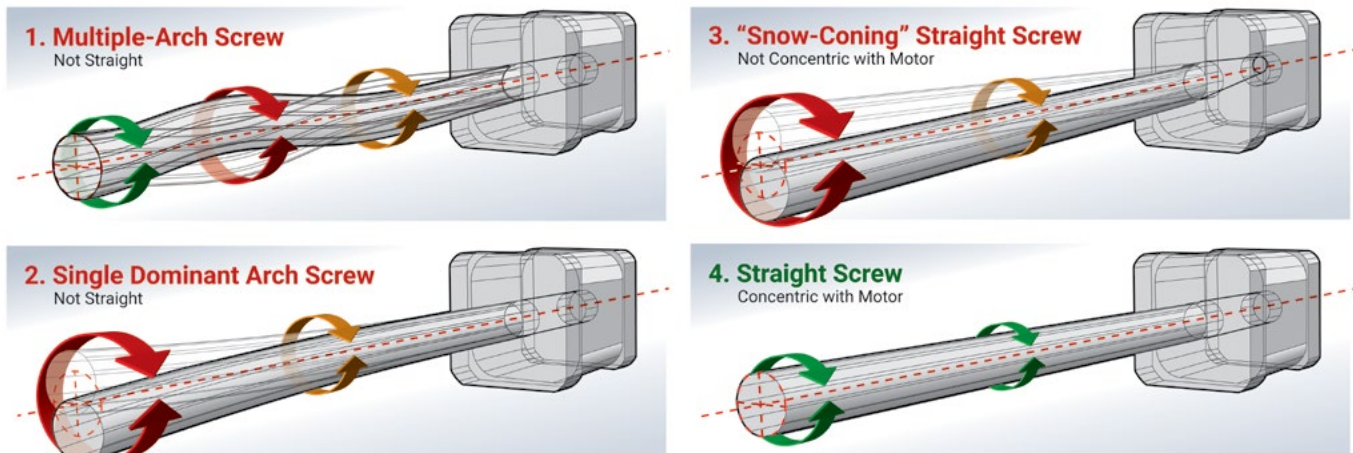

PBC Linear utilizes an automated straightening process and holds tight TIR tolerances to eliminate common lead screw runout and straightness issues

NEMA 8 Series

Connector Part Number:
JST S6B-ZR(LF)(SN)

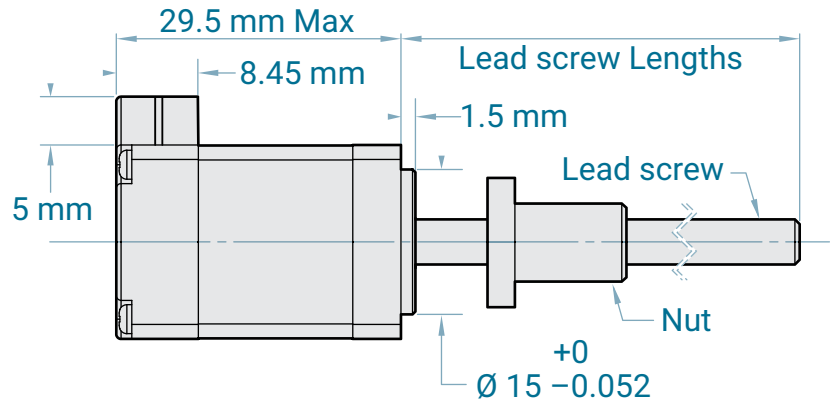
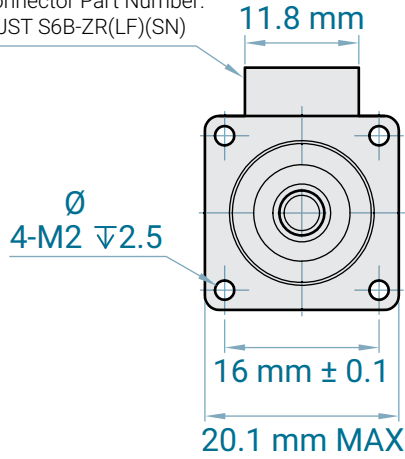

Speed Torque Curves

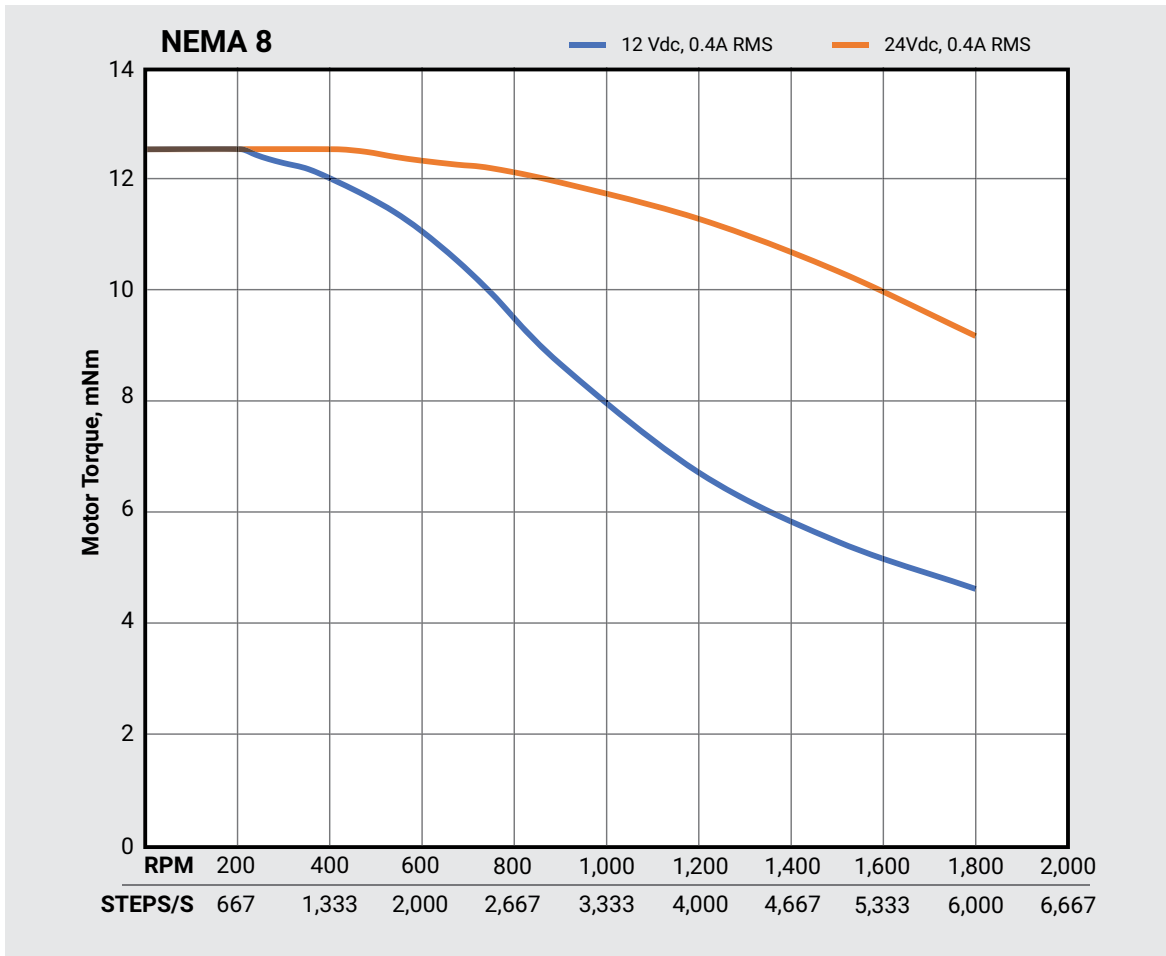

NEMA 11 Series



Phases.....	2	Approvals.....	RoHS
Steps/Revolution.....	200	Operating Temp.....	-20°C–+50°C
Step Accuracy.....	±5%	Insulation Class.....	B (130°C)
IP Rating.....	40	Insulation Resistance.....	100 MΩ

Step Motor - 4 Lead Bi-Polar					
Motor Style	Motor Body Length (mm)	Electrical Connection	Rated Current (Amps)	Winding	
				Ohms	mH
				±10% at 20°C	Typical
NEMA 11	32	Plug In Connector	1	2.7	2.5

Lead Screw Style for NEMA 11 Series			
Lead Screw Style	External Diameter	Lead	Travel Per 1.8° Step
0601	6mm	1mm	.005"
0602		2mm	.010mm
0604		4mm	.020mm
0605		5mm	.025mm
0606		6mm	.030mm
0608		8mm	.040mm
0610		10mm	.050mm
0612		12mm	.060mm
25033	1/4"	.333"	.002"

Note: See page 60 for wiring harness information and diagram.

NEMA 11 Series

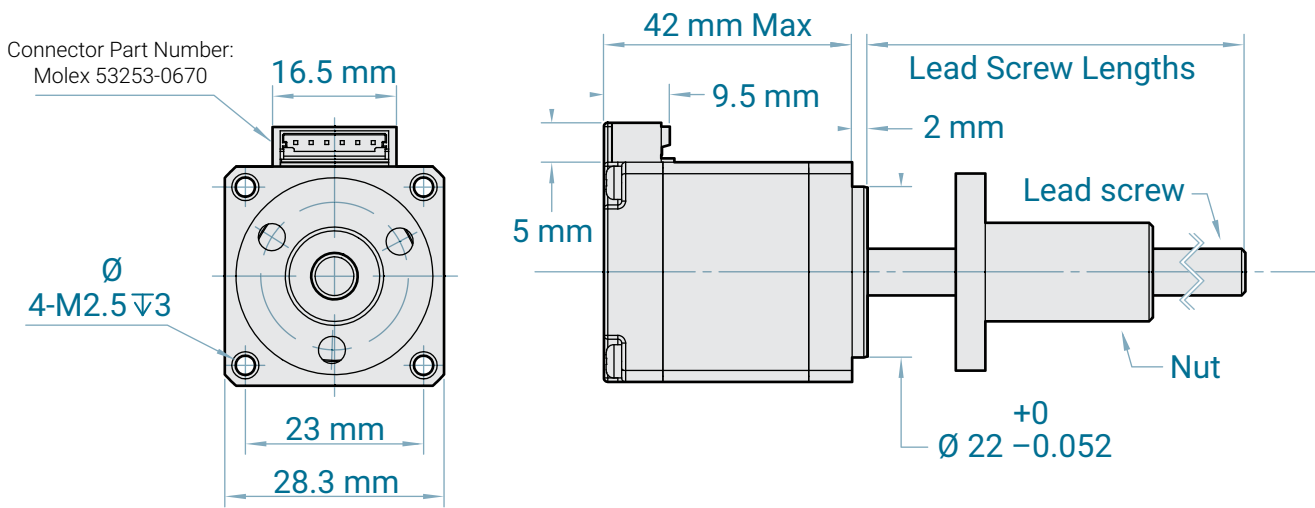

Speed Torque Curves

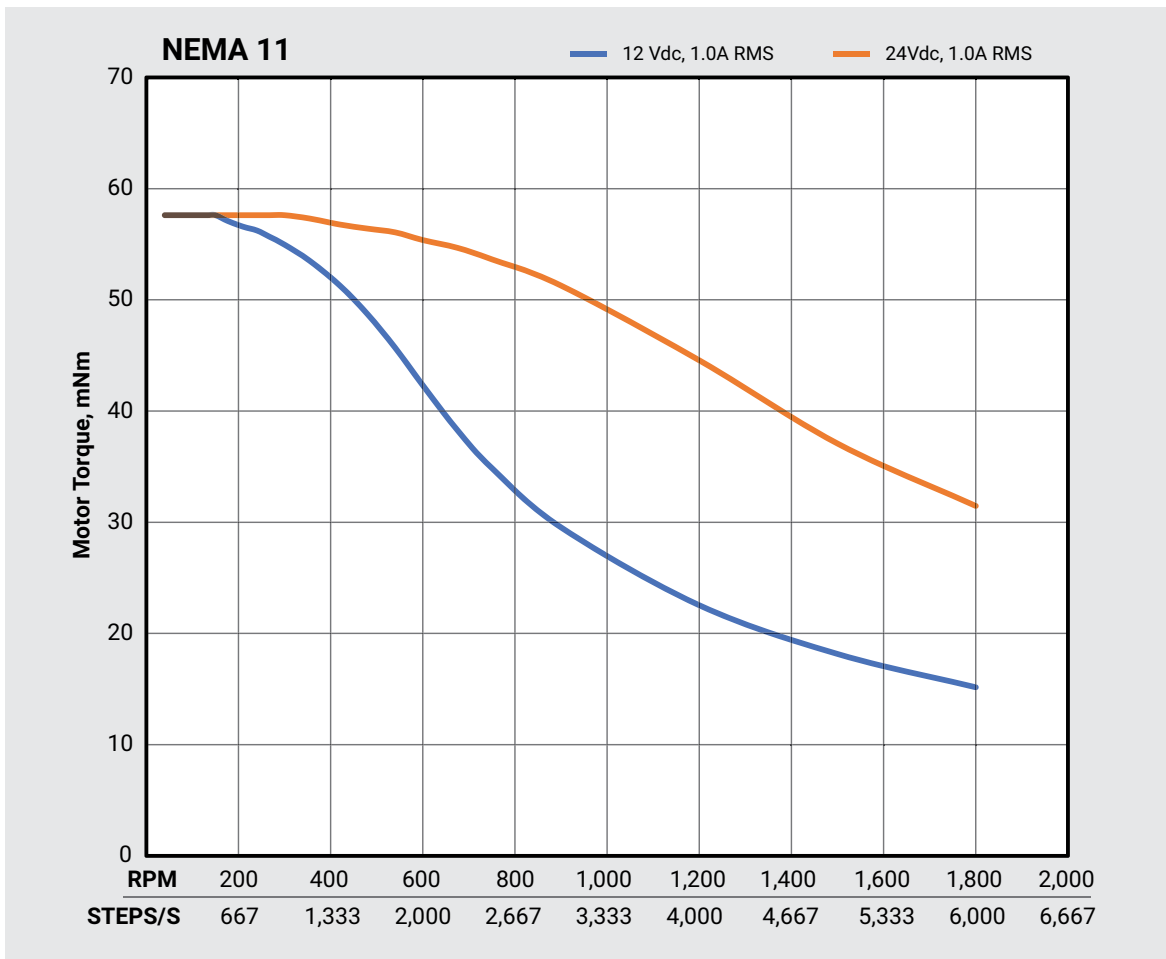

NEMA 14 Series



Phases..... 2
 Steps/Revolution..... 200
 Step Accuracy..... ±5%
 IP Rating..... 40

Approvals..... RoHS
 Operating Temp..... -20°C–+50°C
 Insulation Class..... B (130°C)
 Insulation Resistance..... 100 MΩ

Step Motor - 4 Lead Bi-Polar

Motor Style	Motor Body Length (mm)	Electrical Connection	Rated Current (Amps)	Winding	
				Ohms	mH
				±10% at 20°C	Typical
NEMA 14	36	Plug In Connector	1.5	1.61	2.5

Lead Screw Style for NEMA 14 Series

Lead Screw Style	External Diameter	Lead	Travel Per 1.8° Step	Lead Screw Style	External Diameter	Lead	Travel Per 1.8° Step	
0601	6mm	1mm	0.005"mm	1002	10mm	2mm	.010mm	
0602		2mm	.010mm	1004		4mm	.020mm	
0604		4mm	.020mm	1005		5mm	.025mm	
0605		5mm	.025mm	1006		6mm	.030mm	
0606		6mm	.030mm	1008		8mm	.040mm	
0608		8mm	.040mm	1010		10mm	.050mm	
0610		10mm	.050mm	1012		12mm	.060mm	
0612		12mm	.060mm	1016		16mm	.080mm	
25033		1/4"	.333"	.002"		1025	25mm	.125mm

Note: See page 60 for wiring harness information and diagram.

NEMA 14 Series

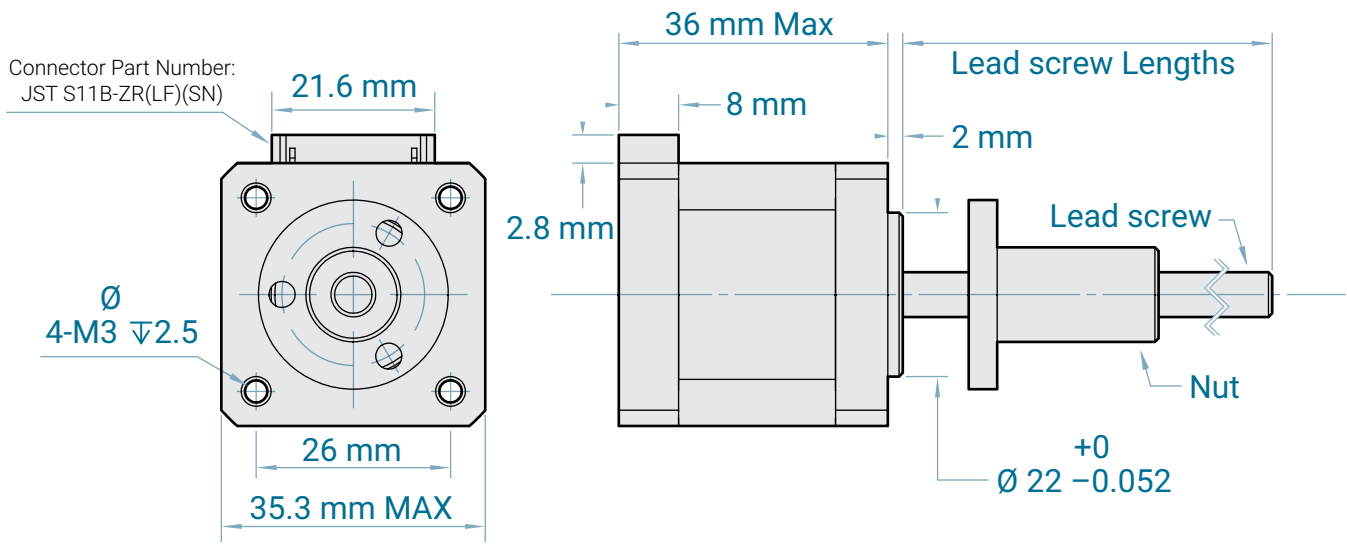

Speed Torque Curves

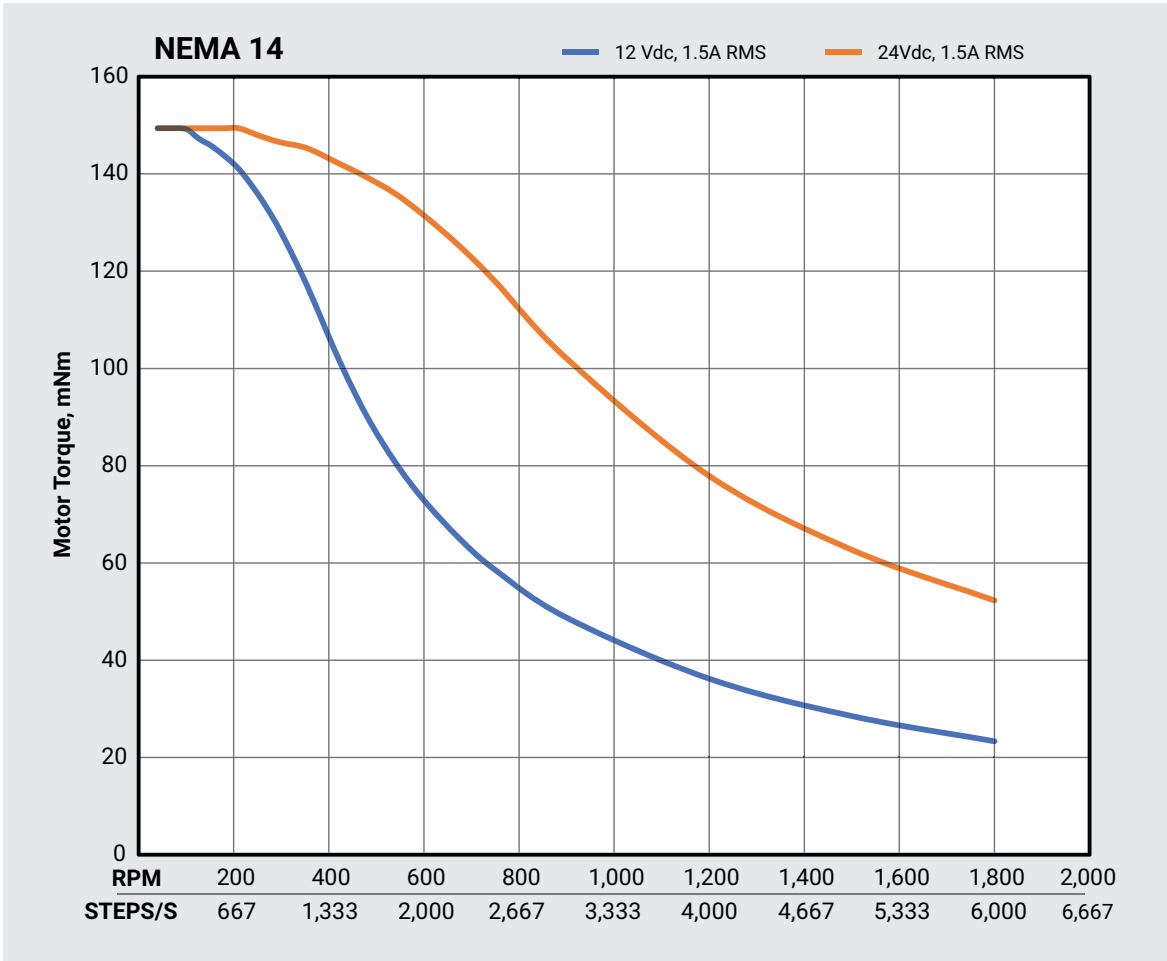

NEMA 17 Series

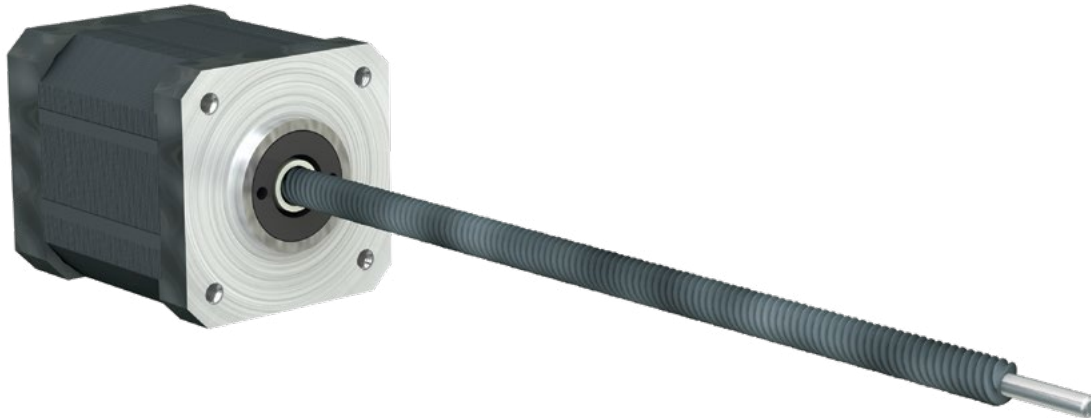

Phases..... 2
 Steps/Revolution..... 200
 Step Accuracy..... ±5%
 IP Rating..... 40

Approvals..... RoHS
 Operating Temp..... -20°C+50°C
 Insulation Class..... B (130°C)
 Insulation Resistance..... 100 MΩ

Step Motor - 4 Lead Bi-Polar

Motor Style	Motor Body Length (mm)	Electrical Connection	Rated Current (Amps)	Winding	
				Ohms	mH
				±10% at 20°C	Typical
NEMA 17 Single Stack	39.8	Plug In Connector	2	1.04	2.73
NEMA 17 Double Stack	48.3	Plug In Connector	2	1.30	2.90

Lead Screw Style for NEMA 17 Series

Lead Screw Style	External Diameter	Lead	Travel Per 1.8° Step	Lead Screw Style	External Diameter	Lead	Travel Per 1.8° Step
0601	6mm	1mm	.005"mm	1010	10mm	10mm	.050mm
0602		2mm	.010mm	1012		12mm	.060mm
0604		4mm	.020mm	1016		16mm	.080mm
0605		5mm	.025mm	1025		25mm	.125mm
0606		6mm	.030mm	43100		7/16"	1"
0608		8mm	.040mm	1201	12mm	1mm	.005mm
0610		10mm	.050mm	1202		2mm	.010mm
0612		12mm	.060mm	1204		4mm	.020mm
25033	1/4"	.333"	.002"	1205		5mm	.025mm
37020	3/8"	.2"	.001"	1206		6mm	.030mm
1001	10mm	1mm	.005mm	1208		8mm	.040mm
1002		2mm	.010mm	1210		10mm	.050mm
1004		4mm	.020mm	1212		12mm	.060mm
1005		5mm	.025mm	1216		16mm	.080mm
1006		6mm	.030mm	1225		25mm	.125mm
1008		8mm	.040mm	50025	1/2"	.25"	.0013"

Note: See page 60 for wiring harness information and diagram.

NEMA 17 Series

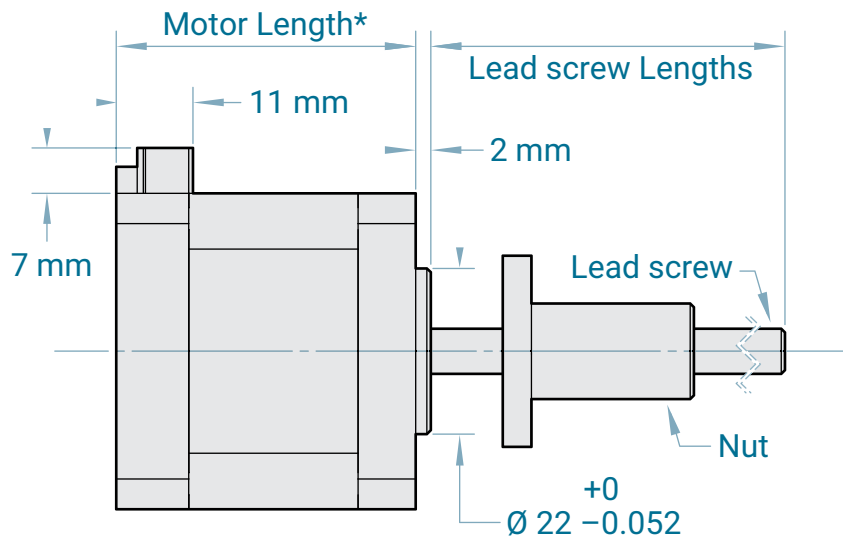
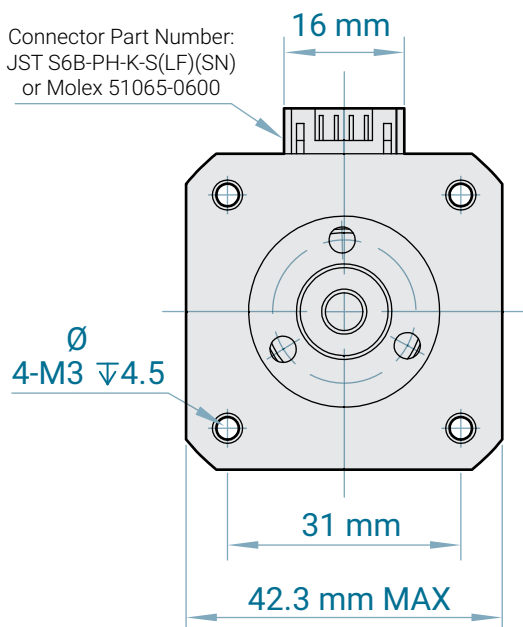

*** Motor Lengths:**
 NEMA 17 Single Stack (171): 39.8 mm
 NEMA 17 Double Stack (172): 48.3 mm

NEMA 17 Series Speed Torque Curves

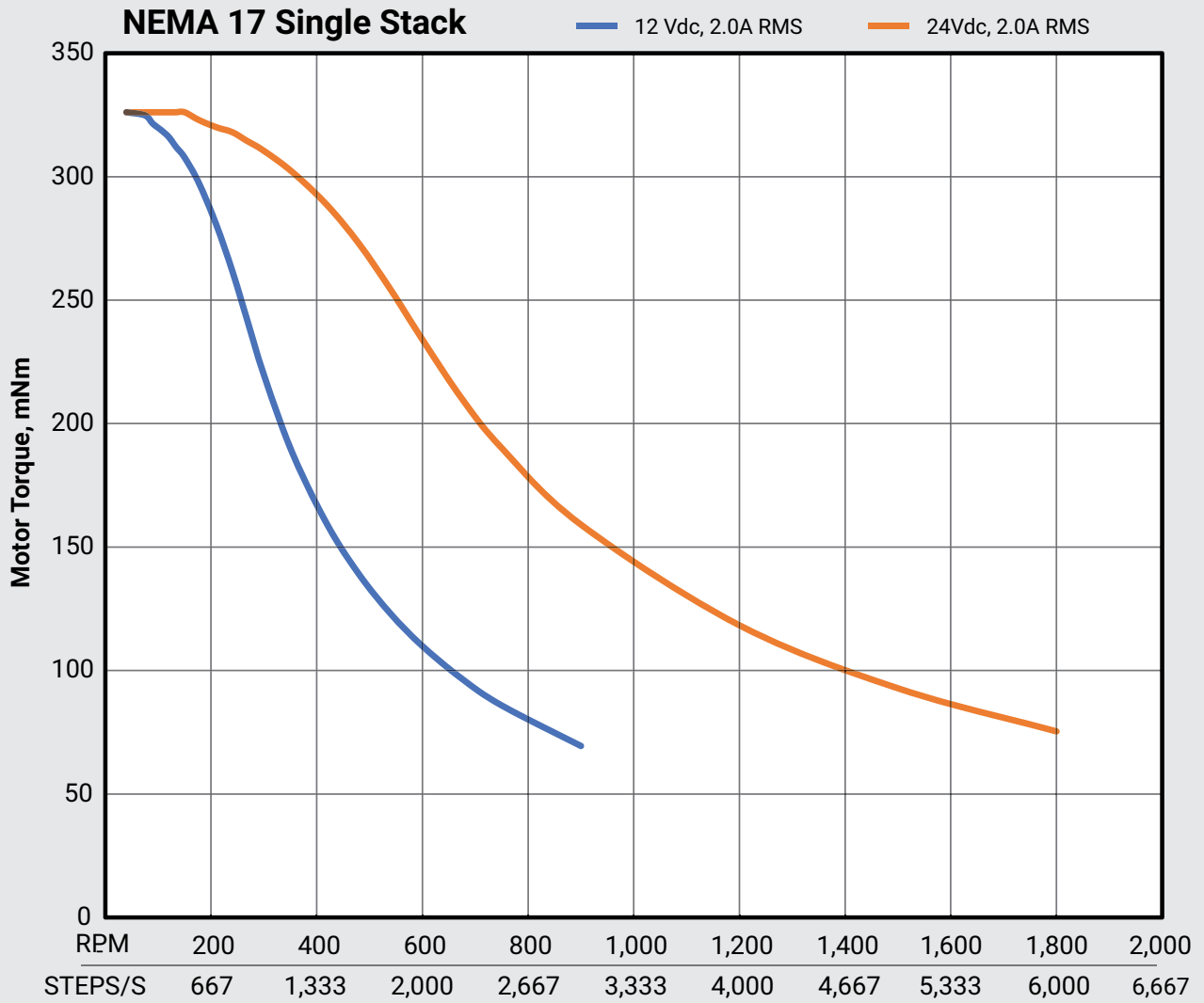

NEMA 17 Series Speed Torque Curves

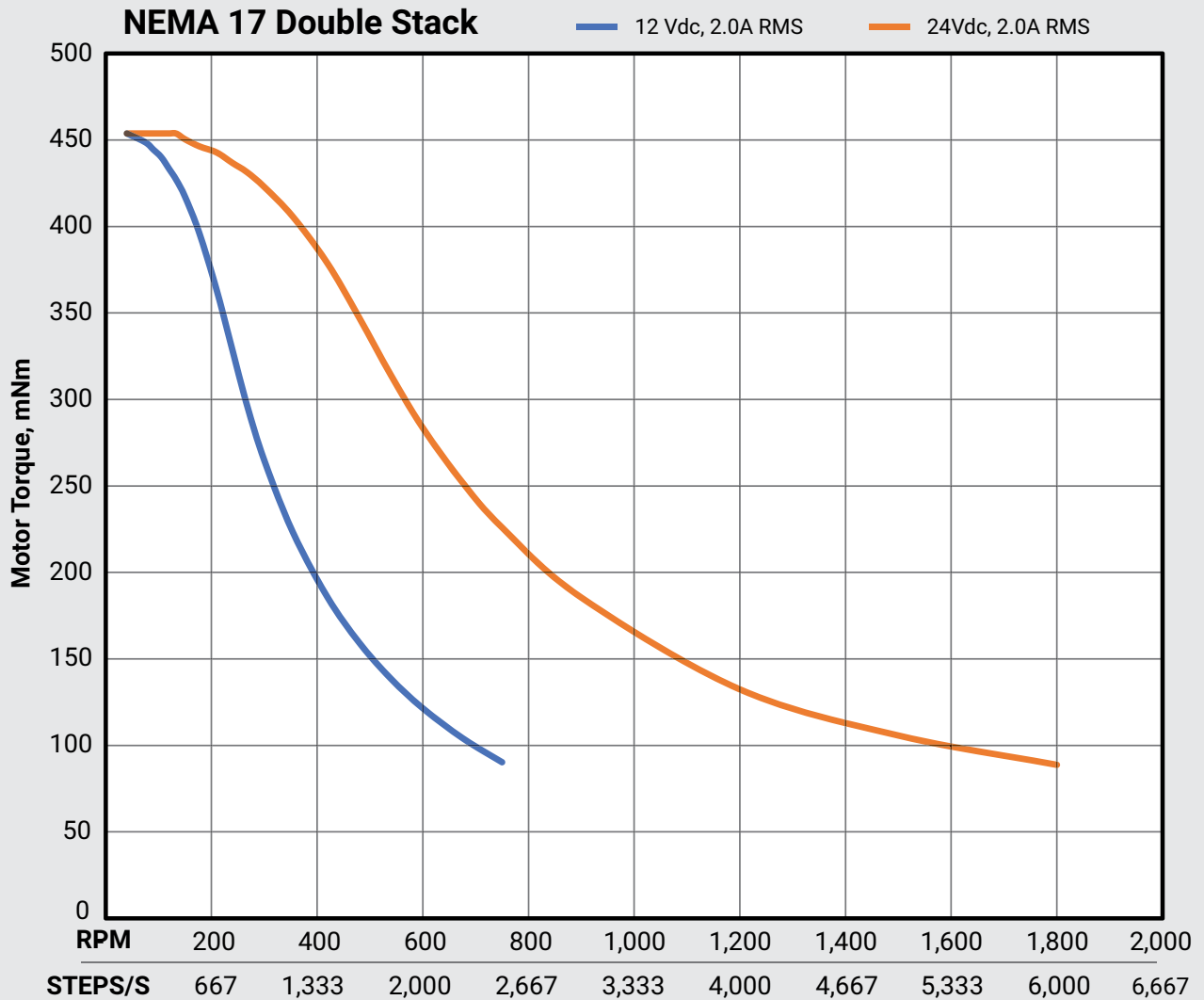

NEMA 23 Series

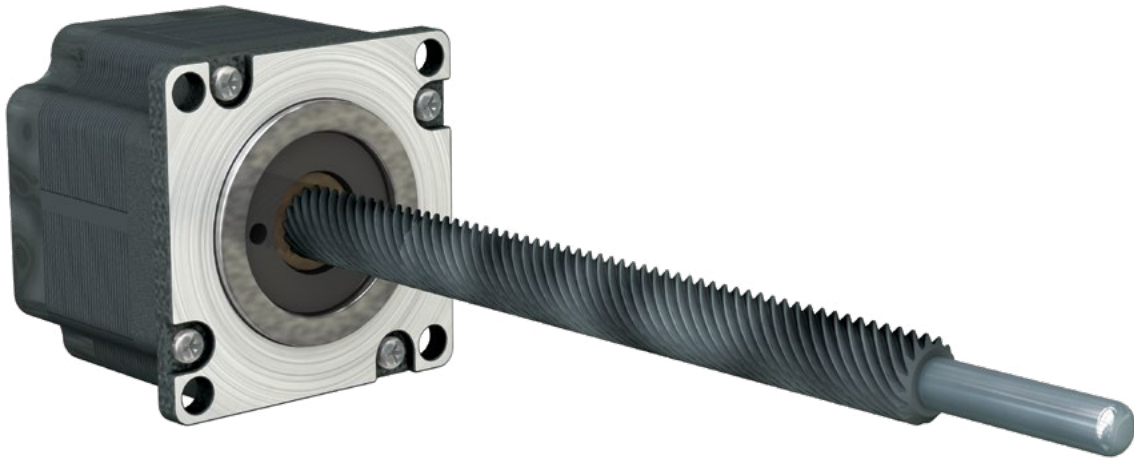

Phases..... 2
 Steps/Revolution..... 200
 Step Accuracy..... ±5%
 IP Rating..... 40

Approvals..... RoHS
 Operating Temp..... -20°C–+50°C
 Insulation Class..... B (130°C)
 Insulation Resistance..... 100 MΩ

Step Motor - 4 Lead Bi-Polar

Motor Style	Motor Body Length (mm)	Electrical Connection	Rated Current (Amps)	Winding		Note
				Ohms	mH	
				±10% at 20°C	Typical	
NEMA 23 Single Stack	57	Plug In Connector	2.2	1.6	7.2	Standard
NEMA 23 Double Stack	79	Plug In Connector	3	1.1	5	Standard
NEMA 23 Power Plus	79	Plug In Connector	3	1.1	3.7	PowerPlus

Lead Screw Style for NEMA 23 Series

Lead Screw Style	External Diameter	Lead	Travel Per 1.8° Step	Lead Screw Style	External Diameter	Lead	Travel Per 1.8° Step
37020	3/8"	.2"	.001"	1206	12mm	6mm	.030mm
1001	10mm	1mm	.005mm	1208		8mm	.040mm
1002		2mm	.010mm	1210		10mm	.050mm
1004		4mm	.020mm	1212		12mm	.060mm
1005		5mm	.025mm	1216		16mm	.080mm
1006		6mm	.030mm	1225		25mm	.125mm
1008		8mm	.040mm	50025		1/2"	.25"
1010		10mm	.050mm	1601	16mm	1mm	.005mm
1012		12mm	.060mm	1602		2mm	.010mm
1016		16mm	.080mm	1604		4mm	.020mm
1025		25mm	.125mm	1605		5mm	.025mm
43100	7/16"	1"	.005"	1606		6mm	.030mm
1201	12mm	1mm	.005mm	1608		8mm	.040mm
1202		2mm	.010mm	1610		10mm	.050mm
1204		4mm	.020mm	1612		12mm	.060mm
1205		5mm	.025mm	1616		16mm	.080mm
				1625		25mm	.125mm

Note: See page 60 for wiring harness information and diagram.

NEMA 23 Series

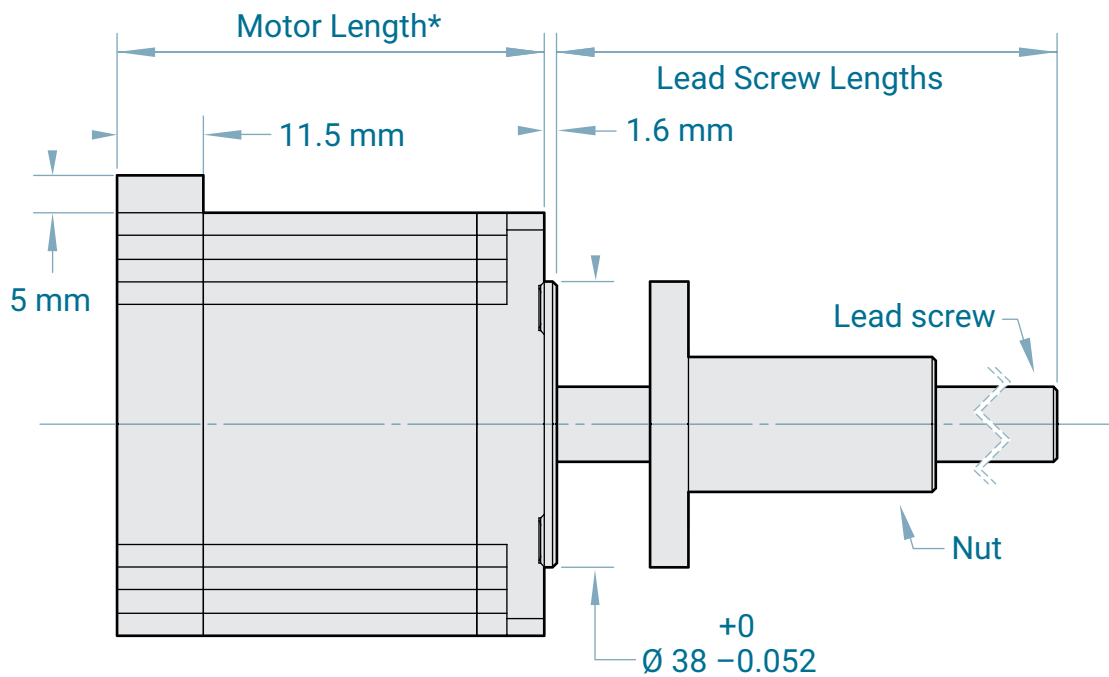
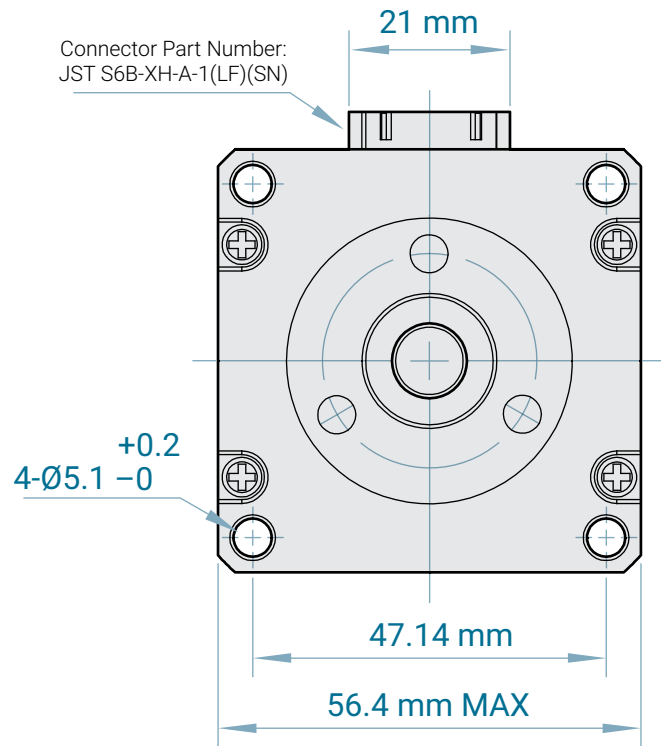

*** Motor Lengths:**
 NEMA 23 Single Stack (231): 57 mm
 NEMA 23 Dpib,e Stack and Power Plus (232, 23P): 79 mm

NEMA 23 Series Speed Torque Curves

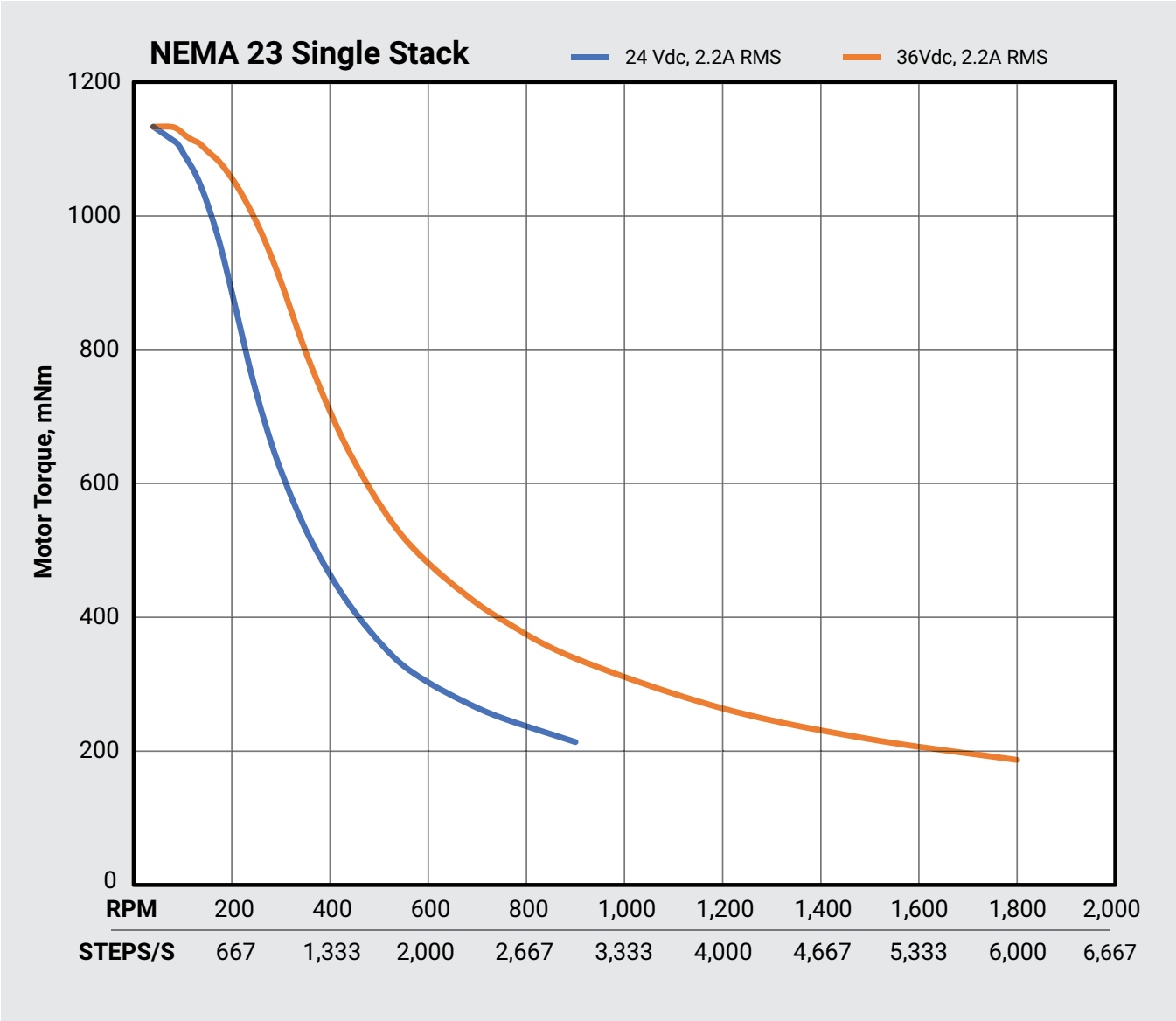

NEMA 23 Series Speed Torque Curves

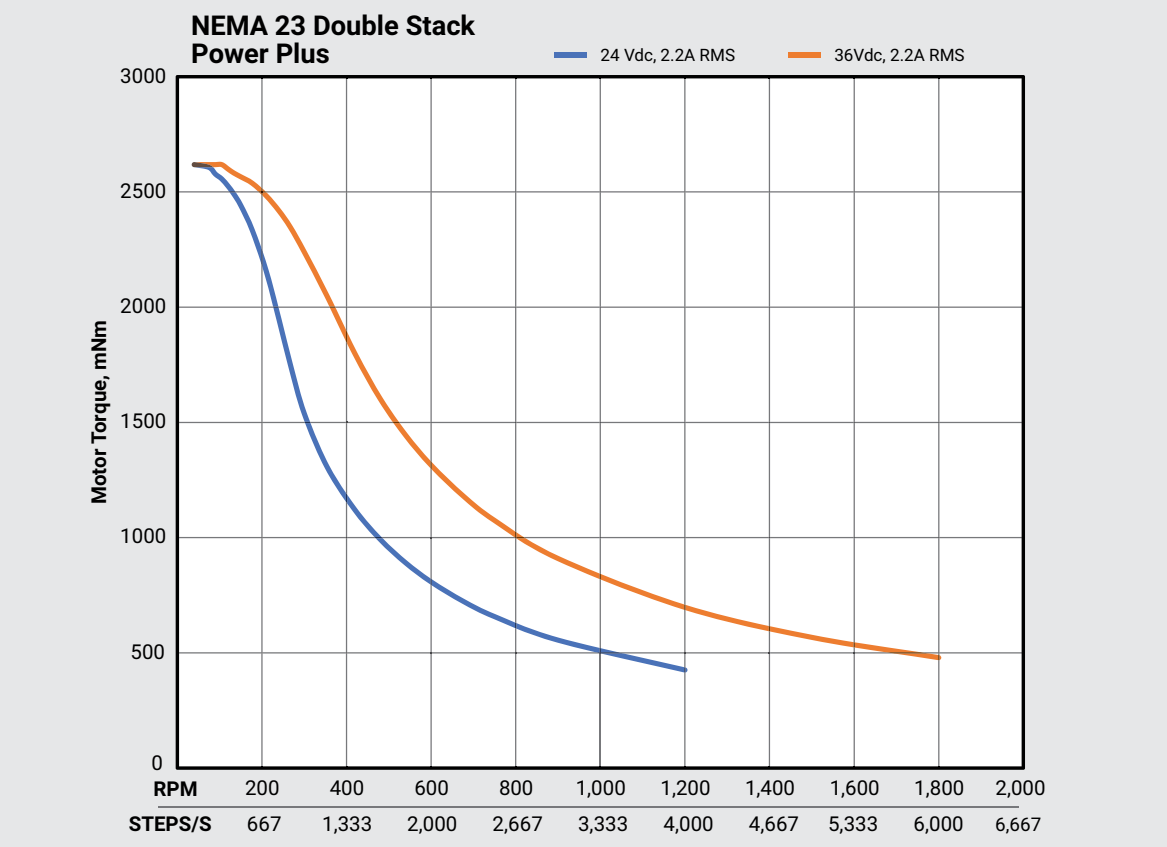
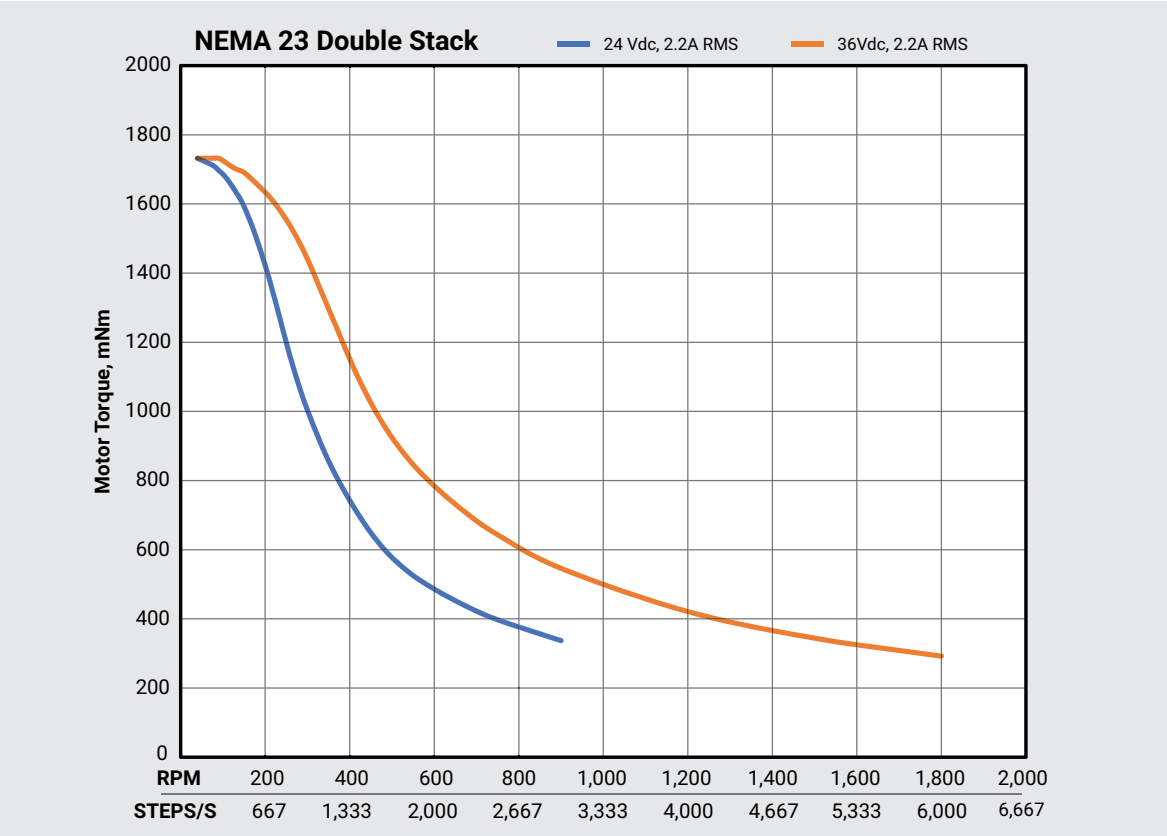

Non-Captive Lead Screw Motors

Deciding when to use a non-captive linear actuator

Non-captive types of lead screw driven linear actuators are different from the more common external versions in that they allow the lead screw to completely pass through the motor. This fundamental difference offers advantages for those that have limited space available or are looking to shrink the overall size of their design package.

The payload or object being moved is attached to the motor, and has screw ends that are typically fixed. In most cases, this setup can allow for a shorter overall screw to be used. It is also ideal for adding the external linear guide bearings that are almost always required for non-captive applications. They provide stiffness and eliminate deflection that causes premature wear on the nut, screw, and internal motor bearings. A less common situation is where the device or payload is attached to the end of the screw. This is only used for very light loads and requires external linear guidance for stiffness. It is an arrangement that also requires clearance for the screw to extend out the opposite side of the motor.

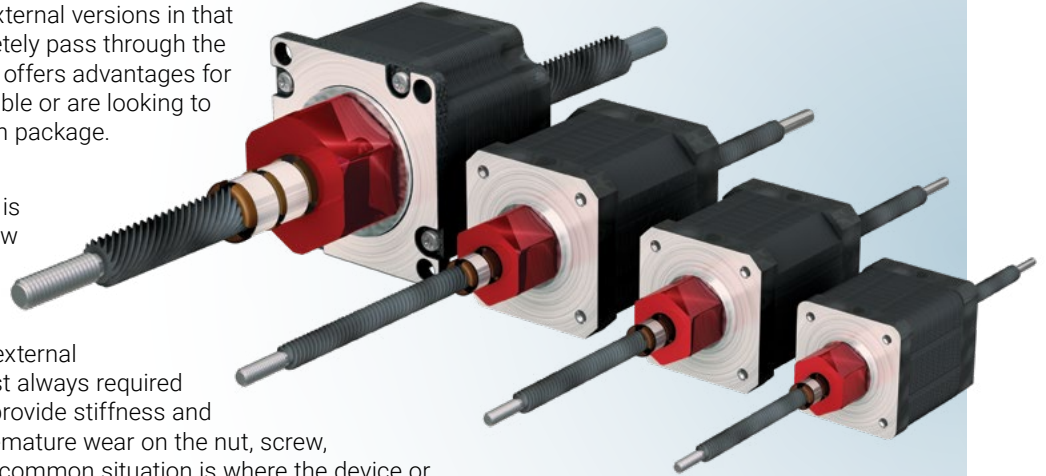

Traditionally, this nut has been a standard nut with no mechanism to account for the play between the external threads of the screw and the internal threads of the nut. PBC Linear have the only anti-backlash nut and lead screw assembly available off-the-shelf in a non-captive configuration. This unique

Hybrid Linear Actuator Selection Chart

Motor Frame	Screw Sizes				
	3/16"	6 mm	1/4"	3/8"	10 mm
NEMA 11	•				
NEMA 14	•	•	•		
NEMA 17	•	•	•		
NEMA 23				•	•

External Configuration

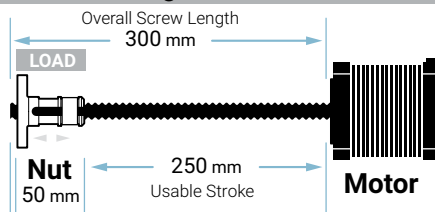

Non-Captive Configuration

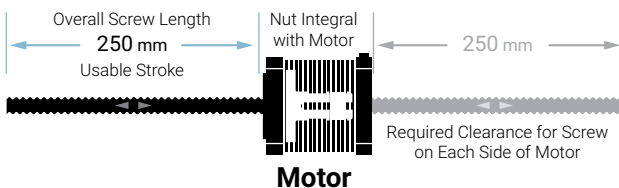

combination offers the best positional performance available in a non-captive hybrid actuator by utilizing our patented Constant Force Technology (CFT), which provides greater than two-times the superior backlash compensation as tested against competitors.

This advantage means that the self-lubricating nut will provide lubricant-free, consistent performance and preload over its lifetime. In addition, screws are available either uncoated or with a proprietary PTFE coating. These screws come with standard lead accuracy of 0.003 inches per foot, which is three-times better than typical screws on the market.

Non-Captive Part Number Configurator

Type	Thread Dir.	Diameter and Lead	Coating	Screw Length	Nut	Motor	Left End	Right End
LS	R	0000	T	0250.00	NCF	000	THR	THR

Type
LS - Lead Screw

Thread Direction
R - Right
L - Left (**Note:** Contact Factory)

Diameter and Lead

Motor	Code	Diameter	Lead
N11	18050	3/16"	0.50"
	18005		0.05"
N14 and N17	25033	1/4"	0.333"
	0601	6 mm	1 mm
	0602		2 mm
	0604		4 mm
	0605		5 mm
	0606		6 mm
	0608		8 mm
	0610		10 mm
0612	12 mm		
N23	37020	3/8"	0.20"
	1001	10 mm	1 mm
	1002		2 mm
	1004		4 mm
	1005		5 mm
	1006		6 mm
	1008		8 mm
	1010		10 mm
	1012		12 mm
	1016		16 mm
	1025		25 mm

Coating
T - PTFE
U - Uncoated

Screw Length
Inch - 0000.00
Metric - 0000
Note: Screw type selected determines if length is inch or metric.

Non-Captive Lead Screw Nuts

NS	Non-Captive Standard
NCF	Non-Captive Anti-Backlash

Left and/or Right Ends

NNN	None
THR	Threaded

Note: See individual motor pages for threaded journal diagram.

Non-Captive Motor Size	
111	Nema 11 (28 mm frame size, 32 mm long) (Requires a 3/16" screw)
112	Nema 11 (283 mm frame size, 41 mm long) (Requires a 3/16" screw)
141	Nema 14 (31 mm frame size) (Requires a 3/16", 1/4", 6 mm screw)
171	Nema 17 (43 mm frame size, 34 mm long) (Requires a 3/16", 1/4", 6 mm screw)
172	Nema 17 (43 mm frame size, 40 mm long) (Requires a 3/16", 1/4", 6 mm screw)
173	Nema 17 (43 mm frame size, 48 mm long) (Requires a 3/16", 1/4", 6 mm screw)
231	Nema 23 (47 mm frame size, 45 mm long) (Requires a 10 mm screw)
232	Nema 23 (47 mm frame size, 57 mm long) (Requires a 10 mm screw)

Sample Part Numbers

Left	Right
<p>250 mm</p> <p>6 x 1 mm</p> <p>NEMA 17</p> <p>LSR0601T-0250-NCF171-NNN-NNN</p>	
<p>6"</p> <p>3/16 x 0.05"</p> <p>NEMA 11</p> <p>LSR18005T-06.00-NS111-THR-THR</p>	



NEMA 11 Non-Captive Series



Phases..... 2
 Steps/Revolution..... 200
 Step Accuracy..... ±5%
 IP Rating..... 40

Approvals..... RoHS
 Operating Temp. -20°C–+50°C
 Insulation Class B (130°C)
 Insulation Resistance 100 MΩ

Step Motor - 4 Lead Bi-Polar

Motor Style	Part Number	Motor Body Length (mm)	Electrical Connection	Rated Current (Amps)	Winding	
					Ohms	mH
					±10% at 20°C	Typical
NEMA 11	111	32	Plug In Connector	0.67	6.1	5.4
NEMA 11	112	41	Plug In Connector	0.95	3.8	3.5

Lead Screw Style for NEMA 11 Series

Lead Screw Style	External Diameter	Lead	Travel Per 1.8° Step
19050	3/16"	0.50"	0.00250"
19005		0.05"	0.00025"

Note: See page 60 for wiring harness information and diagram.

NEMA 11 Non-Captive Series

Connector Part Number:
Molex 51065-0600

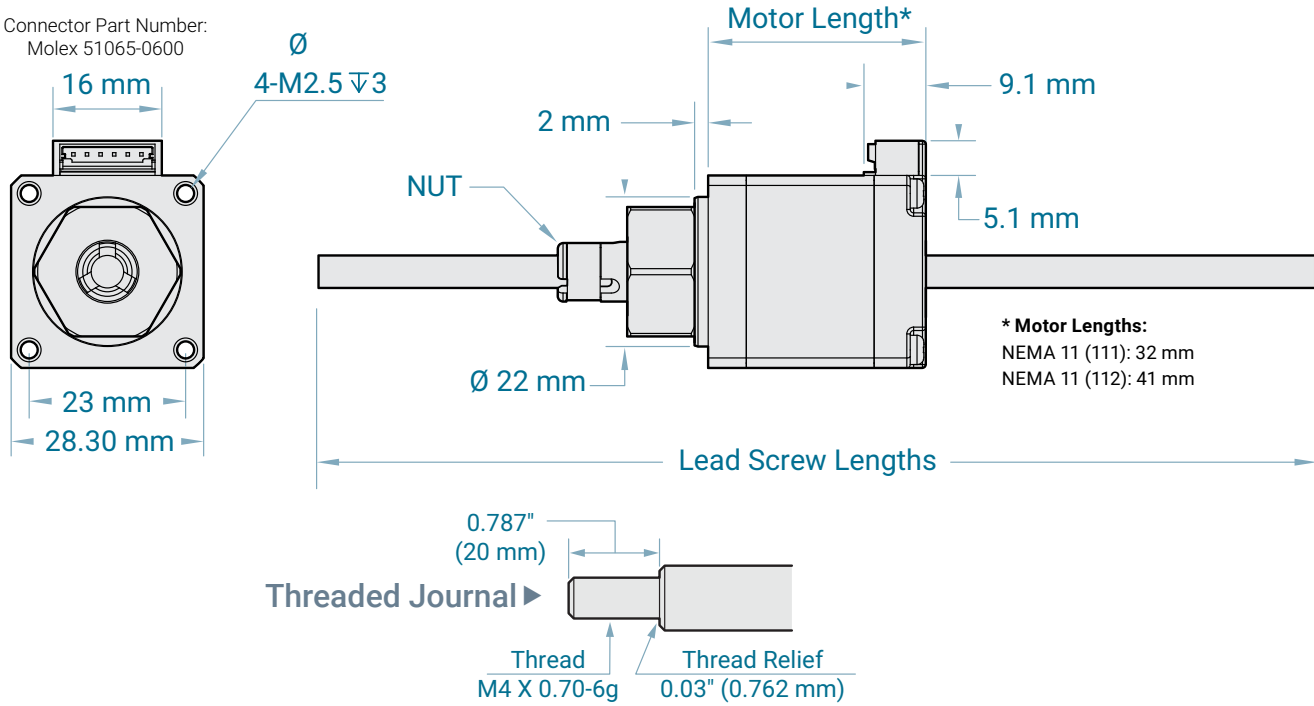

NEMA 11 Non-Captive Speed Torque Curves

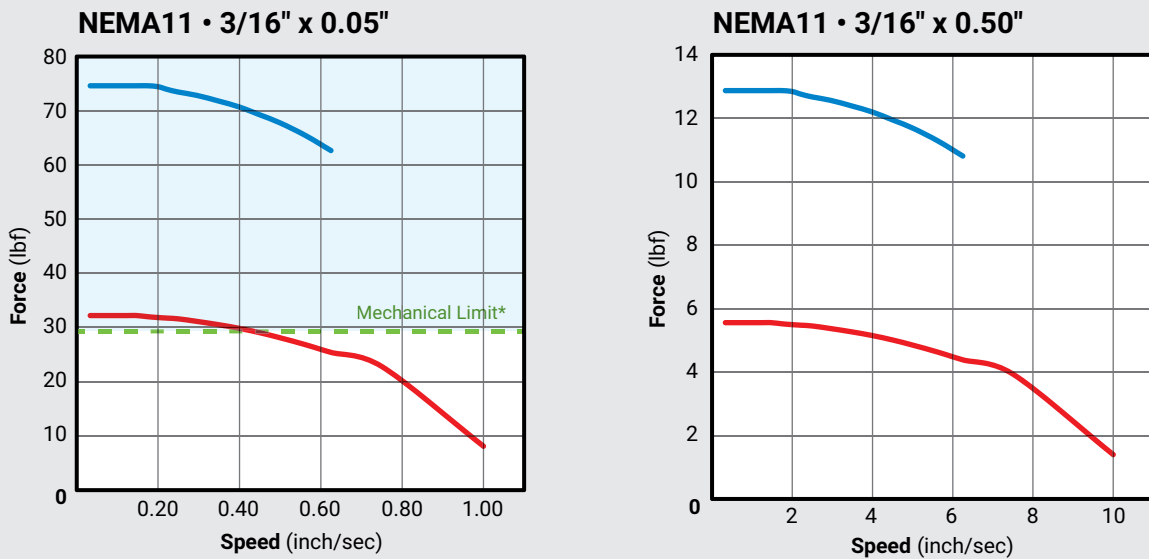

* Mechanical Limit is based on internal motor design and capacity. Do not exceed the Mechanical Limit.

Note: Safety factors should be applied to the capacities in the above charts. Validation of calculated loads should be empirically tested in application conditions.

NEMA 14 Non-Captive Series



Phases..... 2 Approvals..... RoHS
 Steps/Revolution..... 200 Operating Temp..... -20°C–+50°C
 Step Accuracy..... ±5% Insulation Class..... B (130°C)
 IP Rating..... 40 Insulation Resistance..... 100 MΩ

Step Motor - 4 Lead Bi-Polar

Motor Style	Part Number	Motor Body Length (mm)	Electrical Connection	Rated Current (Amps)	Winding	
					Ohms	mH
					±10% at 20°C	Typical
NEMA 14	141	35	Plug In Connector	1.5	1.60	2.5

Lead Screw Style for NEMA 14 Series

Lead Screw Style	External Diameter	Lead	Travel Per 1.8° Step	
19050	3/16"	0.50"	0.00250"	
19005		0.05"	0.00025"	
0601	6 mm	1 mm	0.005 mm	
0602		2 mm	0.010 mm	
0604		4 mm	0.020 mm	
0605		5 mm	0.025 mm	
0606		6 mm	0.030 mm	
0608		8 mm	0.040 mm	
0610		10 mm	0.050 mm	
0612		12 mm	0.060 mm	
25033		1/4"	.333"	0.002"

Note: See page 60 for wiring harness information and diagram.

NEMA 14 Non-Captive Series

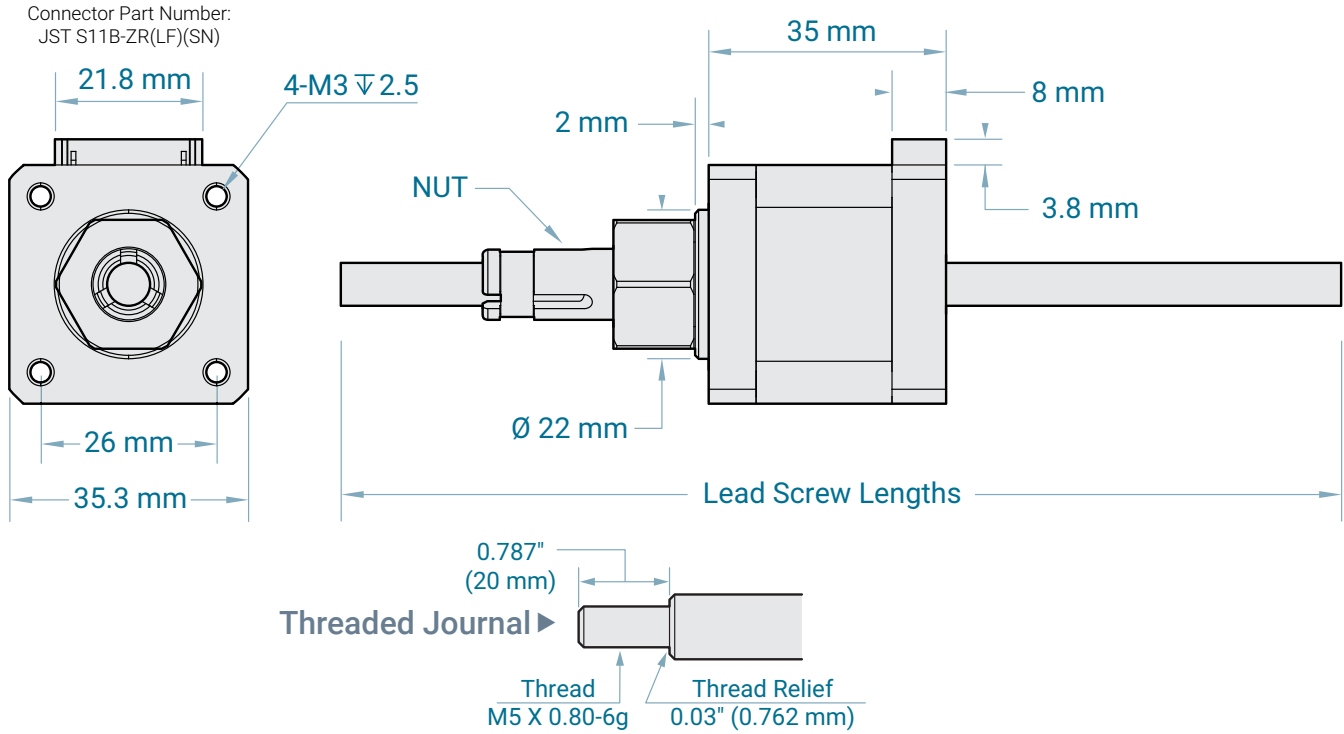

NEMA 14 Non-Captive Speed Torque Curves

141

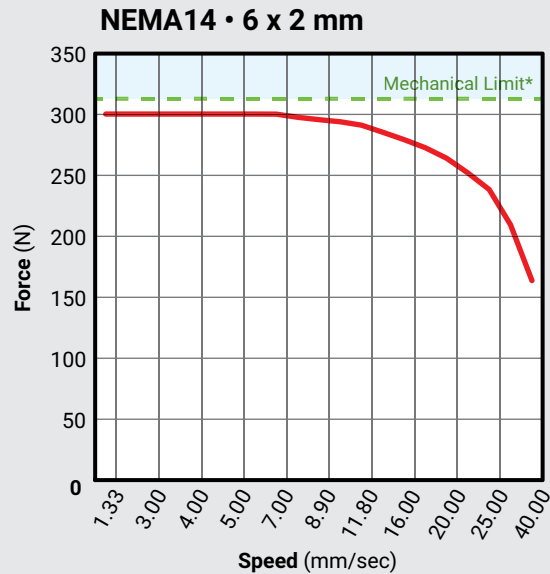
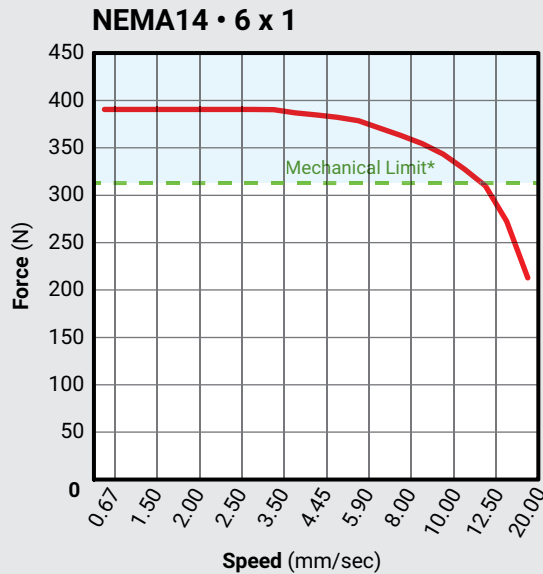

* Mechanical Limit is based on internal motor design and capacity. Do not exceed the Mechanical Limit.

Note: Safety factors should be applied to the capacities in the above charts. Validation of calculated loads should be empirically tested in application conditions.

NEMA 14 Non-Captive Speed Torque Curves

141

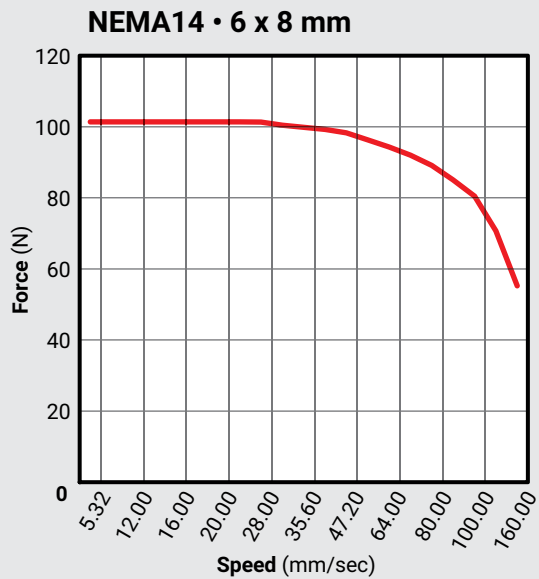
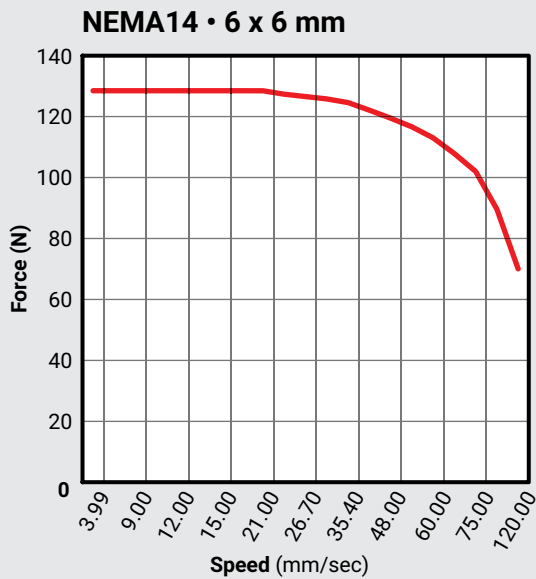
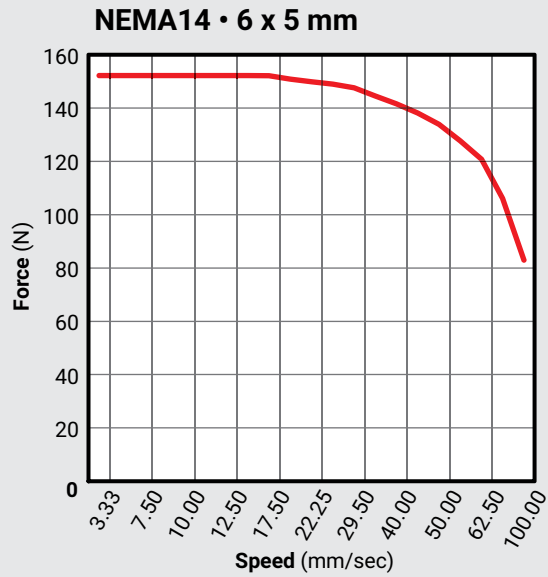
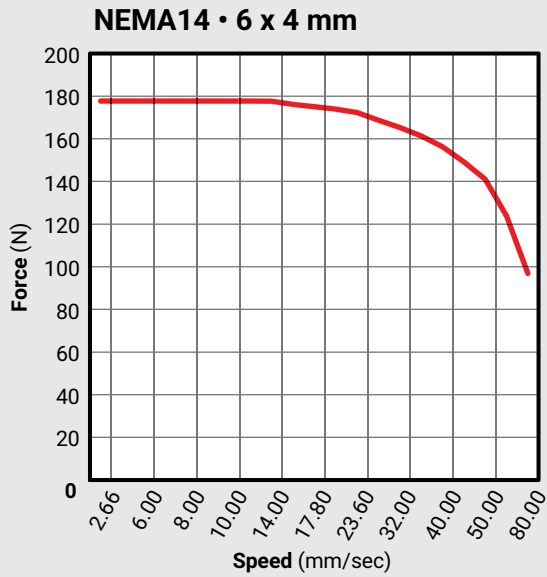

Note: Safety factors should be applied to the capacities in the above charts. Validation of calculated loads should be empirically tested in application conditions.

NEMA 14 Non-Captive Speed Torque Curves

141

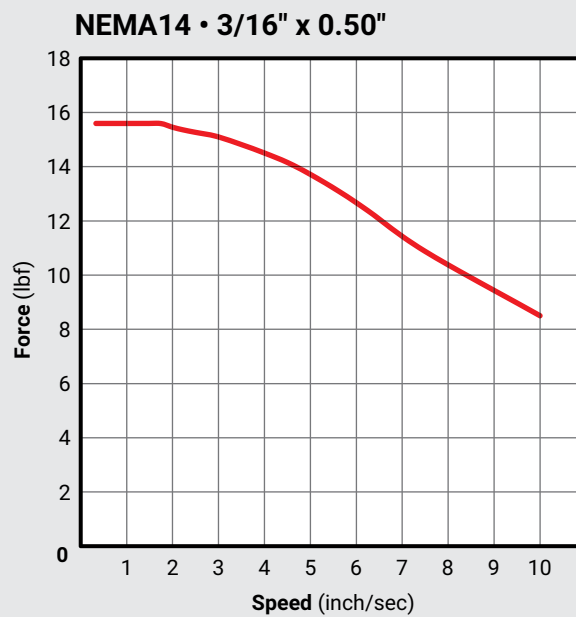
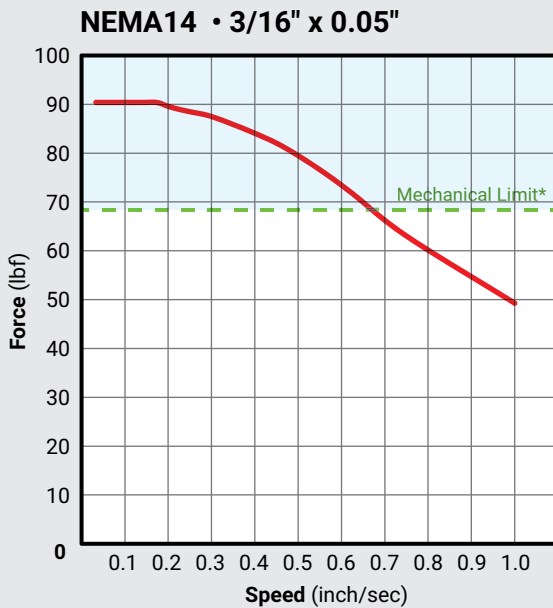
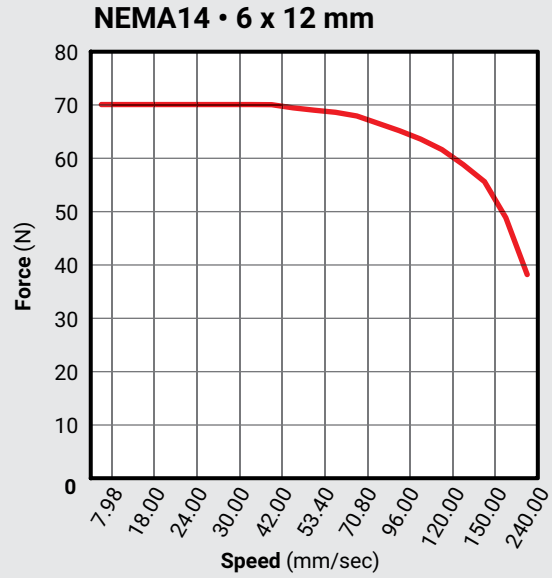
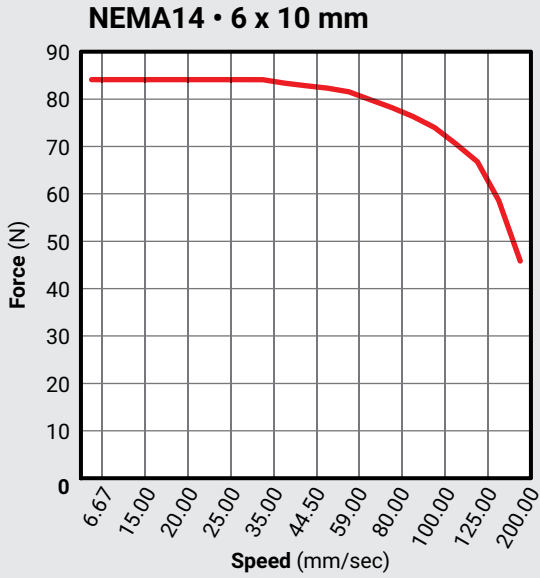

* Mechanical Limit is based on internal motor design and capacity. Do not exceed the Mechanical Limit.

Note: Safety factors should be applied to the capacities in the above charts. Validation of calculated loads should be empirically tested in application conditions.

NEMA 17 Non-Captive Series

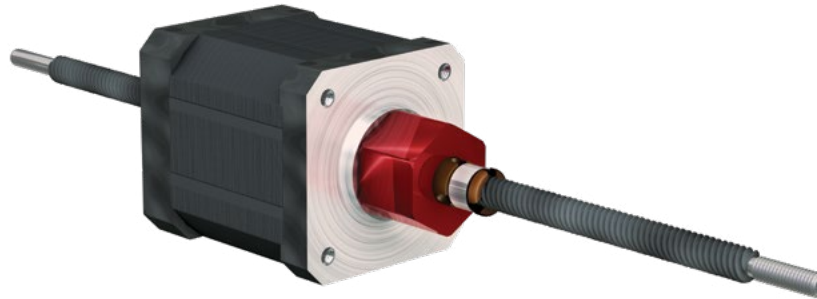

Phases..... 2
 Steps/Revolution..... 200
 Step Accuracy..... ±5%
 IP Rating..... 40

Approvals..... RoHS
 Operating Temp. -20°C+50°C
 Insulation Class B (130°C)
 Insulation Resistance 100 MΩ

Step Motor - 4 Lead Bi-Polar

Motor Style	Part Number	Motor Body Length (mm)	Electrical Connection	Rated Current (Amps)	Winding	
					Ohms	mH
					±10% at 20°C	Typical
NEMA 17	171	34.3	Plug In Connector	1.0	4.30	7.7
NEMA 17	172	39.8	Plug In Connector	1.5	1.98	5.3
NEMA 17	173	48.3	Plug In Connector	2.0	1.30	3.1

Lead Screw Style for NEMA 17 Series

Lead Screw Style	External Diameter	Lead	Travel Per 1.8° Step	
19050	3/16"	0.50"	0.00250"	
19005		0.05"	0.00025"	
0601	6 mm	1 mm	0.005 mm	
0602		2 mm	0.010 mm	
0604		4 mm	0.020 mm	
0605		5 mm	0.025 mm	
0606		6 mm	0.030 mm	
0608		8 mm	0.040 mm	
0610		10 mm	0.050 mm	
0612		12 mm	0.060 mm	
25033		1/4"	0.333"	0.002"

Note: See page 60 for wiring harness information and diagram.

NEMA 17 Non-Captive Series

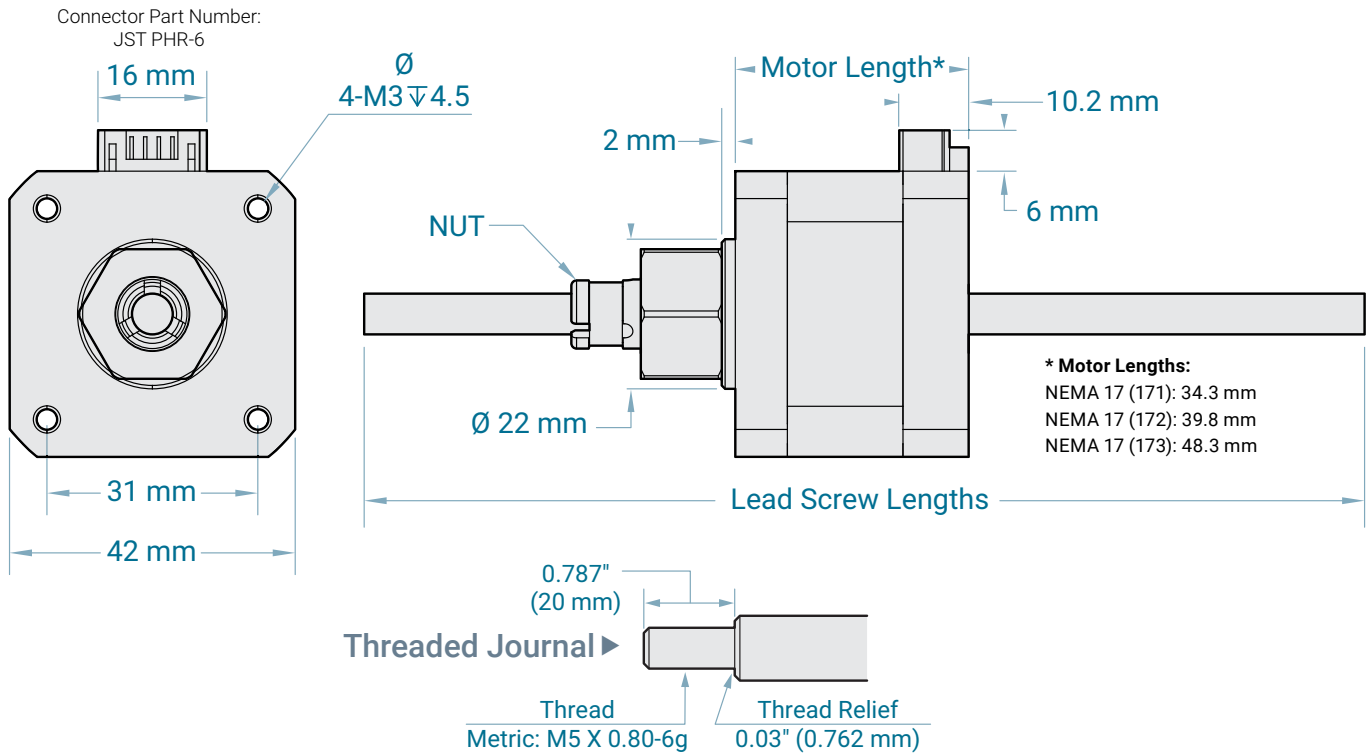

NEMA 17 Non-Captive Speed Torque Curves

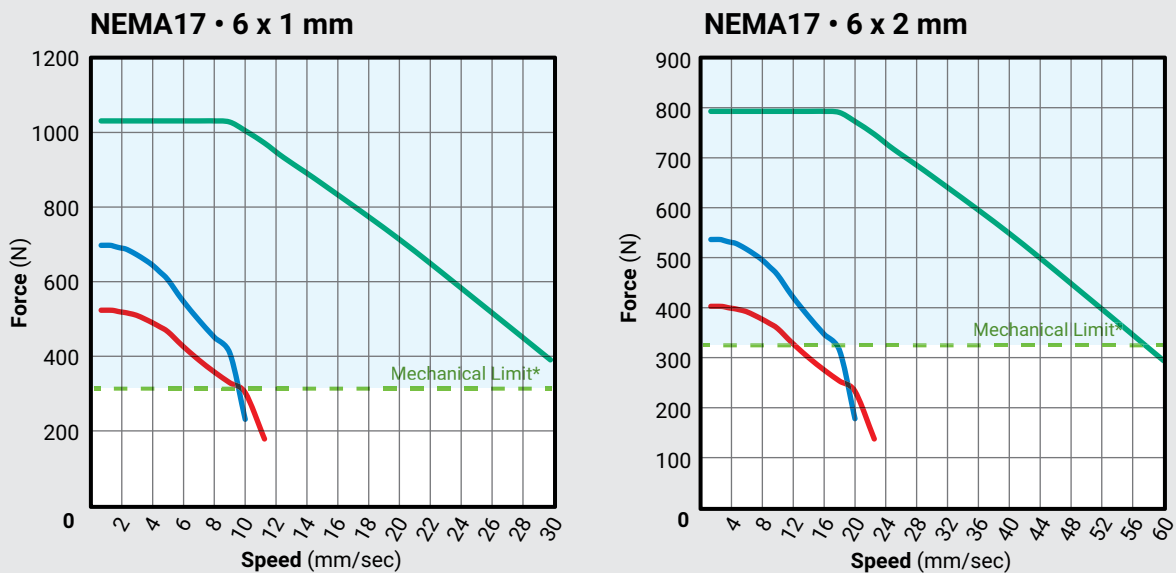

* Mechanical Limit is based on internal motor design and capacity. Do not exceed the Mechanical Limit.

Note: Safety factors should be applied to the capacities in the above charts. Validation of calculated loads should be empirically tested in application conditions.

NEMA 17 Non-Captive Speed Torque Curves

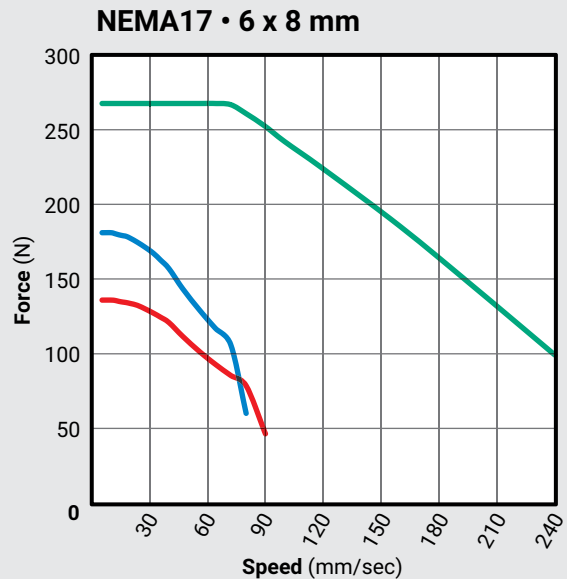
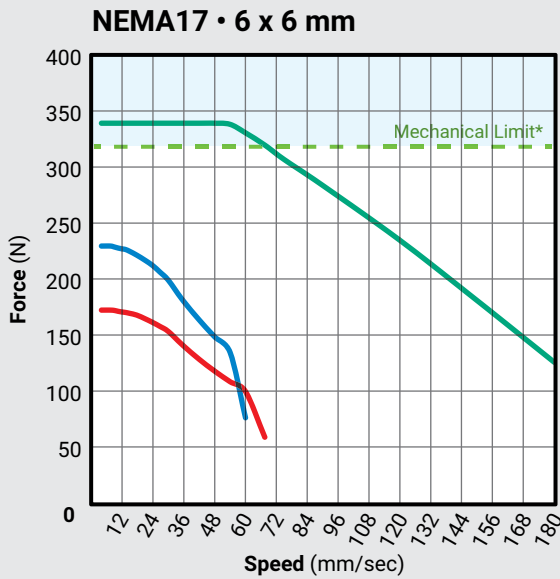
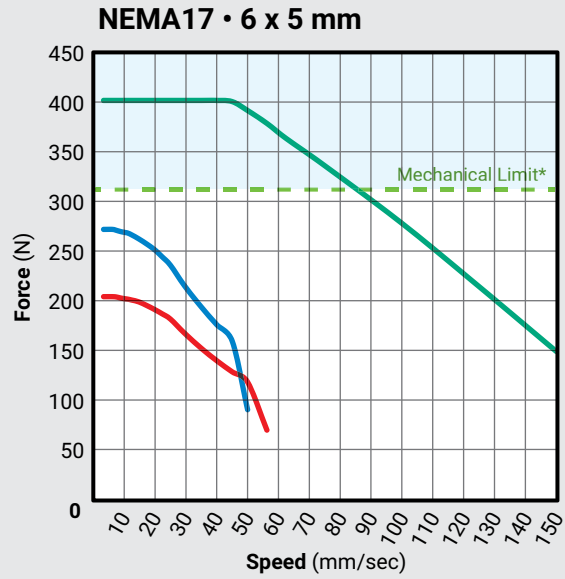
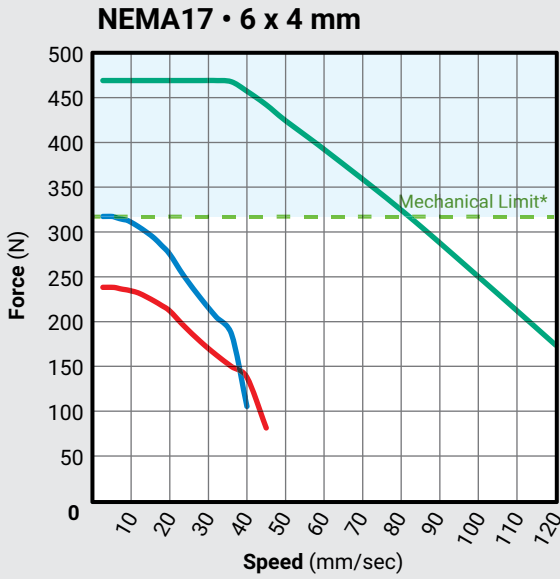
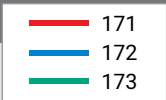

* Mechanical Limit is based on internal motor design and capacity. Do not exceed the Mechanical Limit.
Note: Safety factors should be applied to the capacities in the above charts. Validation of calculated loads should be empirically tested in application conditions.

NEMA 17 Non-Captive Speed Torque Curves

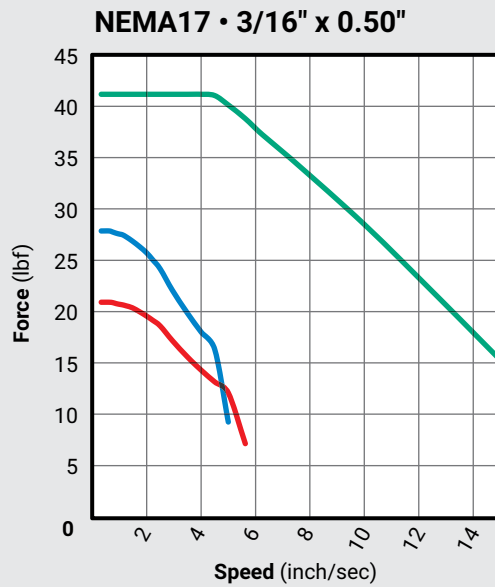
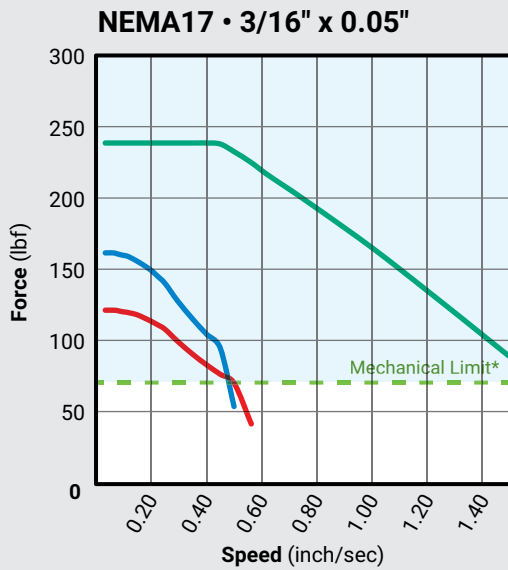
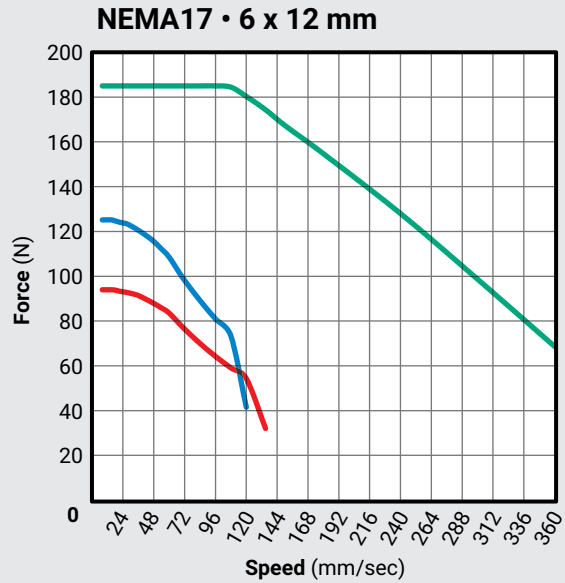
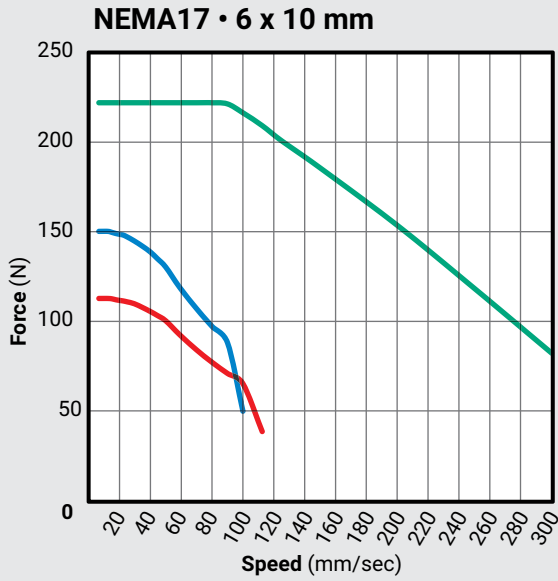
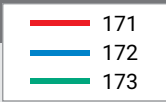

* Mechanical Limit is based on internal motor design and capacity. Do not exceed the Mechanical Limit.

Note: Safety factors should be applied to the capacities in the above charts. Validation of calculated loads should be empirically tested in application conditions.

NEMA 23 Non-Captive Series



Phases 2 Approvals RoHS
 Steps/Revolution 200 Operating Temp. -20°C–+50°C
 Step Accuracy ±5% Insulation Class B (130°C)
 IP Rating 40 Insulation Resistance 100 MΩ

Step Motor - 4 Lead Bi-Polar

Motor Style	Part Number	Motor Body Length (mm)	Electrical Connection	Rated Current (Amps)	Winding	
					Ohms	mH
					±10% at 20°C	Typical
NEMA 23	231	45	Plug In Connector	2.1	1.54	4.1
NEMA 23	232	57	Plug In Connector	2.2	1.60	7.2

Lead Screw Style for NEMA 23 Series

Lead Screw Style	External Diameter	Lead	Travel Per 1.8° Step
37020	3/8"	0.20"	0.001"
1001	10 mm	1 mm	0.005 mm
1002		2 mm	0.010 mm
1004		4 mm	0.020 mm
1005		5 mm	0.025 mm
1006		6 mm	0.030 mm
1008		8 mm	0.040 mm
1010		10 mm	0.050 mm
1012		12 mm	0.060 mm
1016		16 mm	0.080 mm
1025		25 mm	0.125 mm

Note: See page 60 for wiring harness information and diagram.

NEMA 23 Non-Captive Series

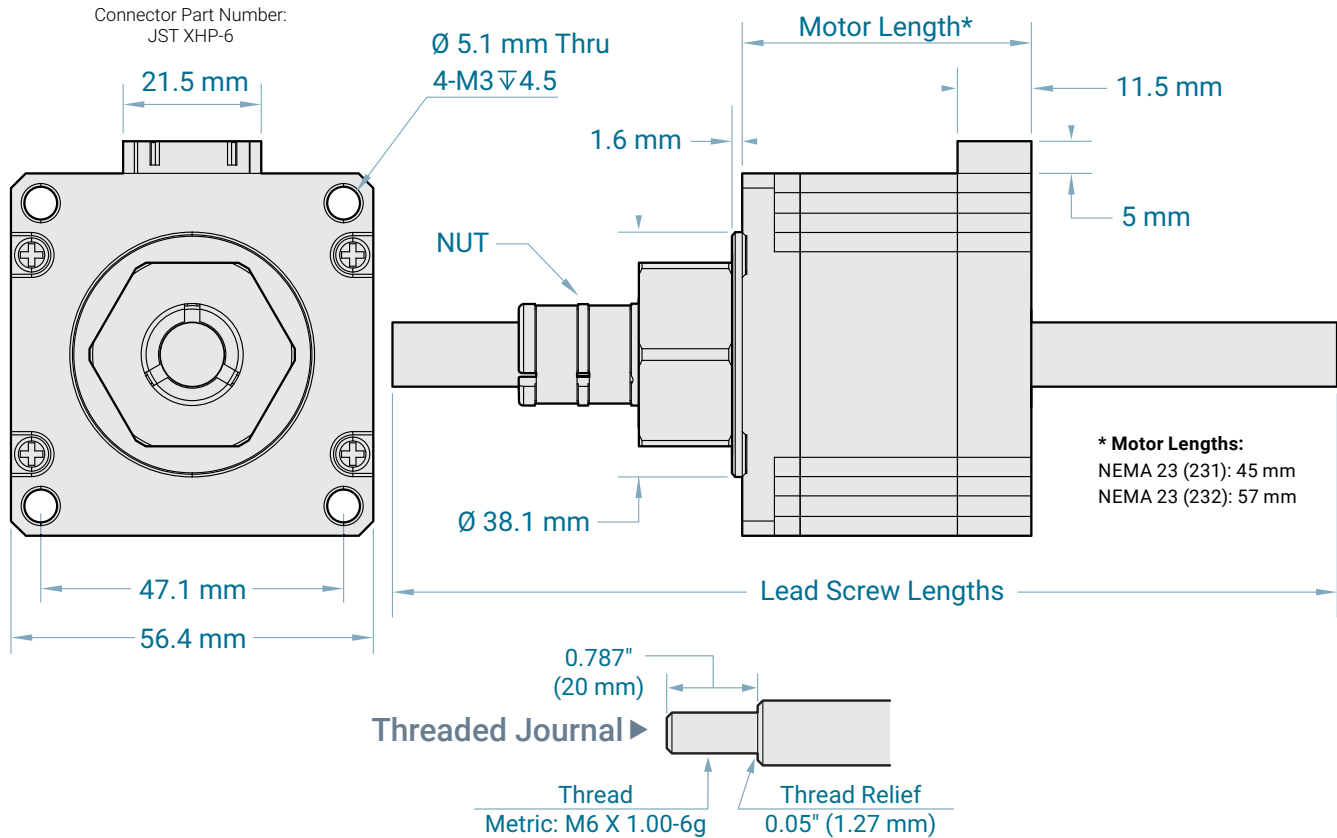

NEMA 23 Non-Captive Speed Torque Curves

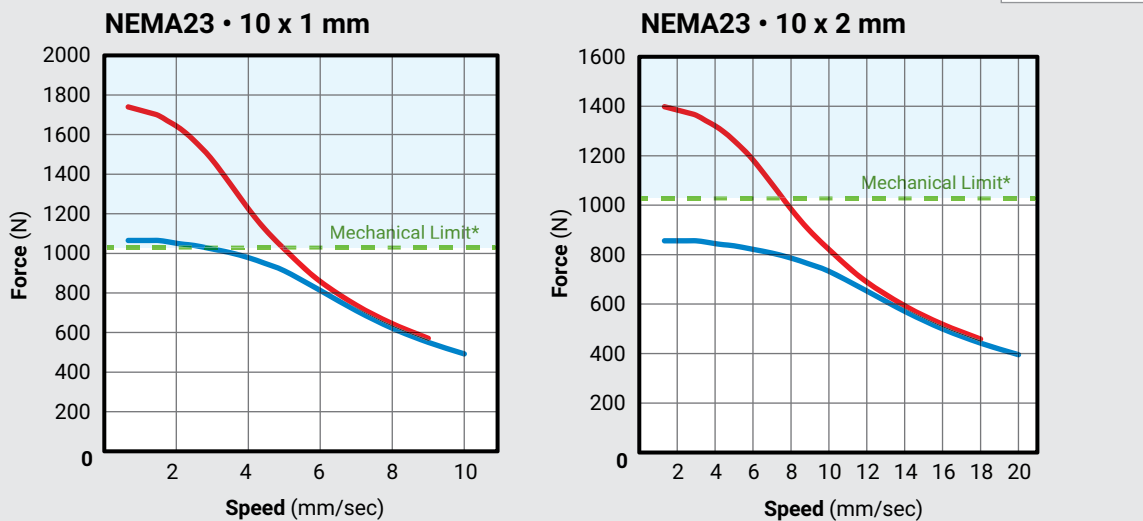

* Mechanical Limit is based on internal motor design and capacity. Do not exceed the Mechanical Limit.
Note: Safety factors should be applied to the capacities in the above charts. Validation of calculated loads should be empirically tested in application conditions.

NEMA 23 Non-Captive Speed Torque Curves

— 231
— 232

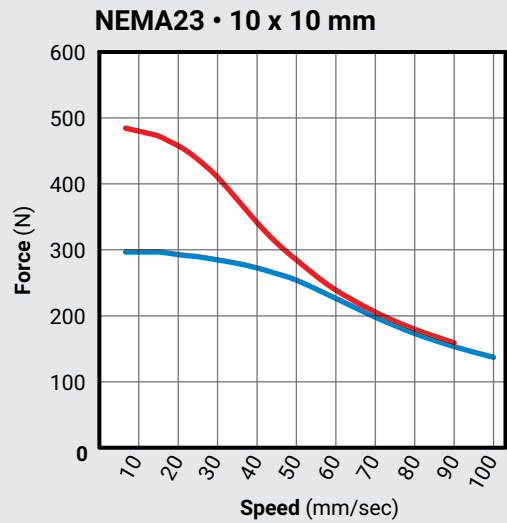
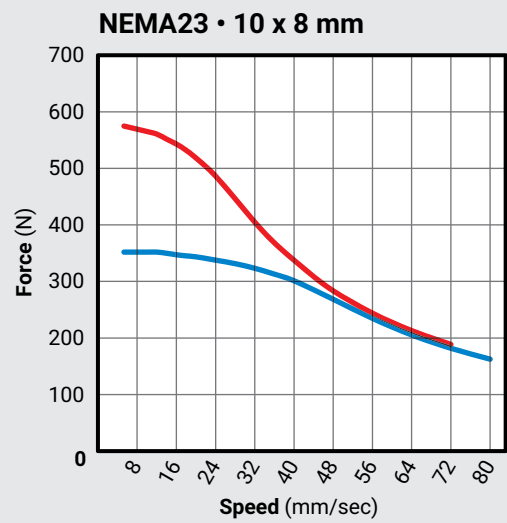
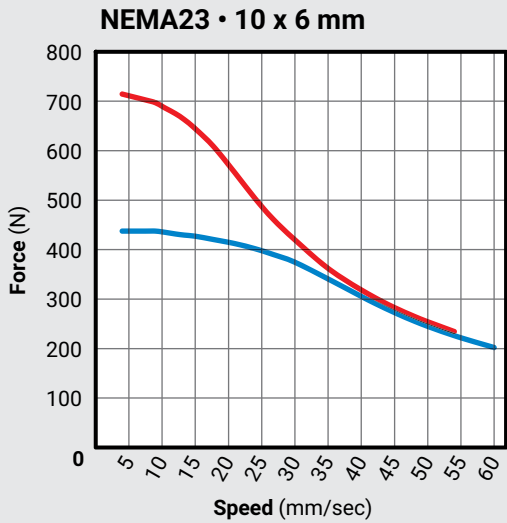
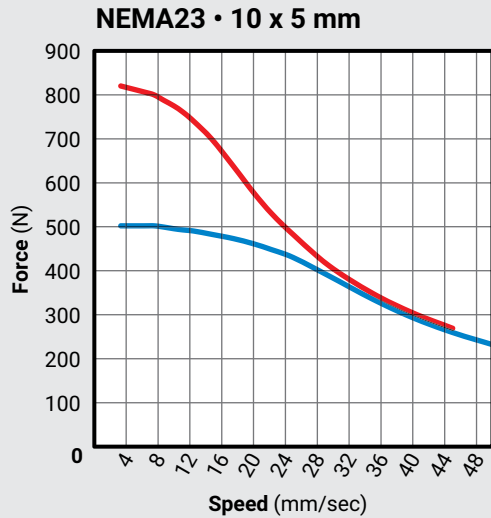
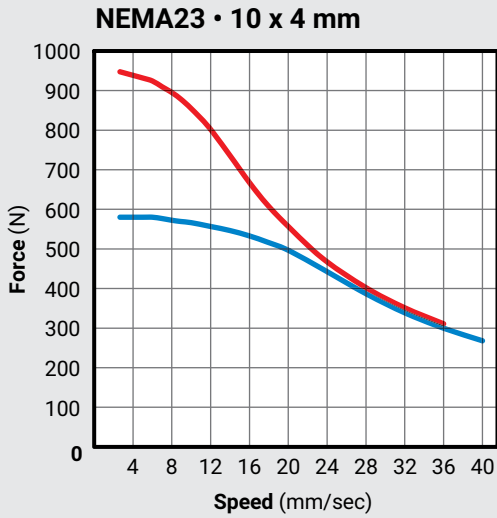

Note: Safety factors should be applied to the capacities in the above charts. Validation of calculated loads should be empirically tested in application conditions.

NEMA 23 Non-Captive Speed Torque Curves

— 231
— 232

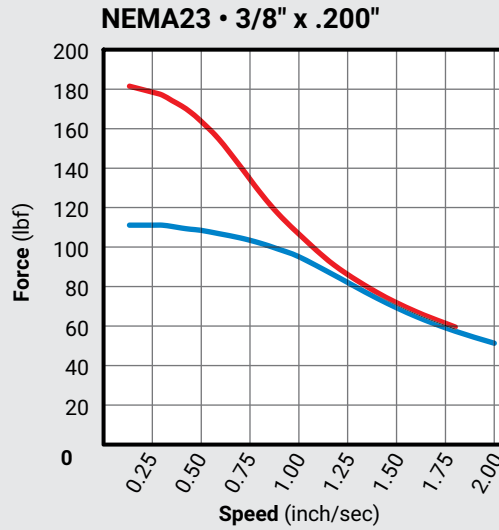
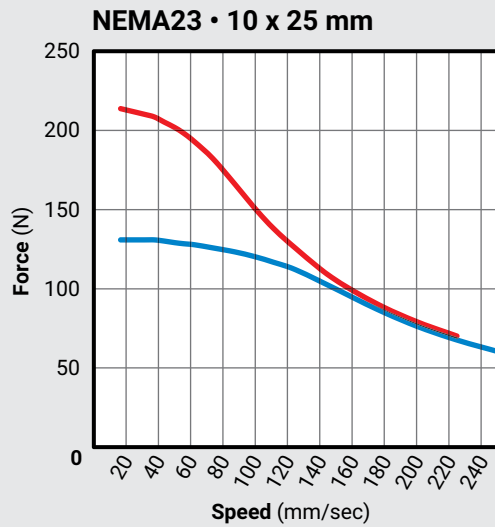
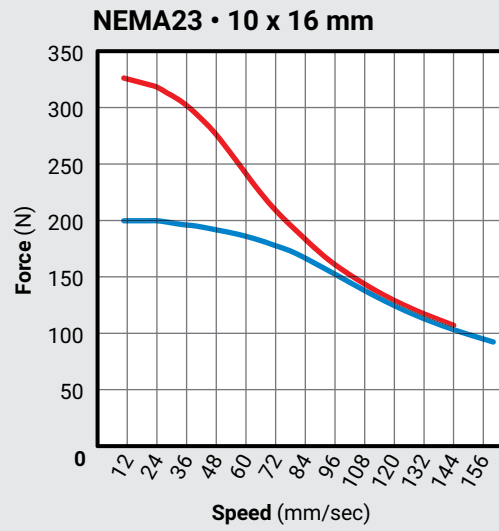
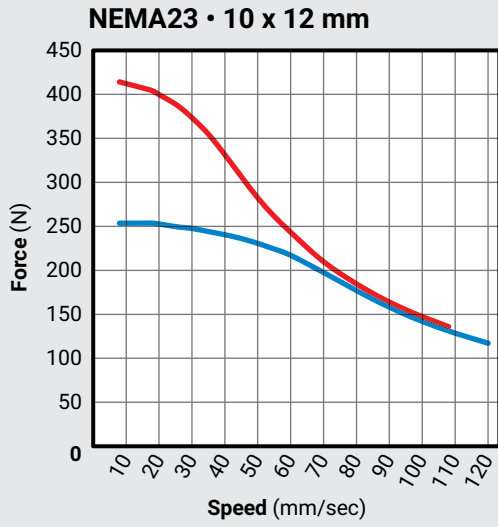

Note: Safety factors should be applied to the capacities in the above charts. Validation of calculated loads should be empirically tested in application conditions.

Wiring Harnesses

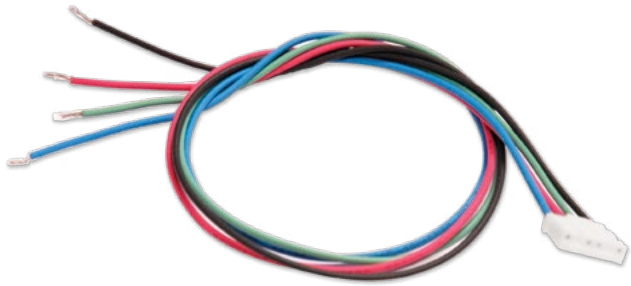

NEMA 11 Series

4 Lead Part Number 6200727

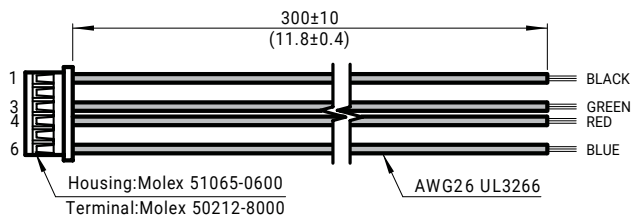

NEMA 17 Series

4 Lead Part Number 6200490

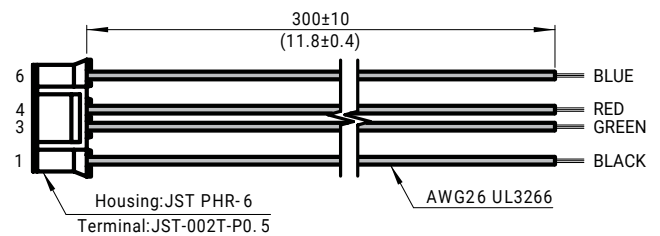

NEMA 14 Series

4 Lead Part Number 6200728

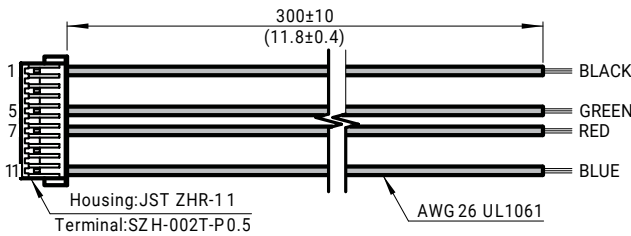

NEMA 23 Series

4 Lead Part Number 6200491

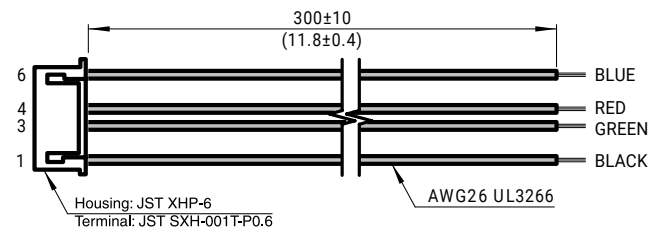

Wiring Diagram

Bipolar, Full Step

Step	Phase 1		Phase 2	
	A	C	B	D
1	+	-	+	-
2	-	+	+	-
3	-	+	-	+
4	+	-	-	+

CW (downward arrow) and CCW (upward arrow) rotation when seen from flange side of the motor.

CW & CCW rotation when seen from flange side of the motor.

4 Lead (bipolar)

Connector Pin#

Motor Size

8, 11, 17, 23 | 14

1	1	A	
3	5	C	
4	7	B	
6	11	D	

PBC Linear Line of Actuators and Key Features

LSM



LSM Lead Screw Motors And Hybrid Linear Actuators

- 6, 10, 12, and 16 mm diameters; 1 - 25 mm leads
- Custom sizes, materials, and finishes available
- Constant Force™ screw and nut
 - Patent pending self-adjusting anti-backlash feature
 - Patent pending coil spring adjustable nut
- 300 series stainless steel screw with PTFE coating
- NEMA 17, 23, 34 flange sizes—single, double, triple stack stepper motors

MLB



ML Series

- Compact profile 28 x 32 mm for small-scale automation
- High speed precision, enhanced load capacities, and precise repeatability
- Linear guide supports—available in single or dual rails
- Long travel lengths—up to 650 mm

Compact



Compact Series

- Plain bearing or ball bearing options
- Lead screw diameter and lead options
- Constant Force Technology nuts or standard fixed nuts
- Motor options: Integrated motor or motor mount setup

SIMO



SIMO® Series—Versatile, Flexible, Affordable

- All critical edges machined concurrently in one pass
- Integrated or motor mount drive mechanism
- Built to either low profile or tall base rail

PLA



MT Series

- High acceleration, speeds, and rigidity—long travel lengths
- Fully enclosed aluminum housing
- Strong yet lightweight and corrosion-resistant

MTB



PL Series

- Enclosed aluminum housing with Integral V™ raceway
- High speed cam roller design is sealed against contamination
- Many accessories—sensors, mounting brackets, etc.

MUK

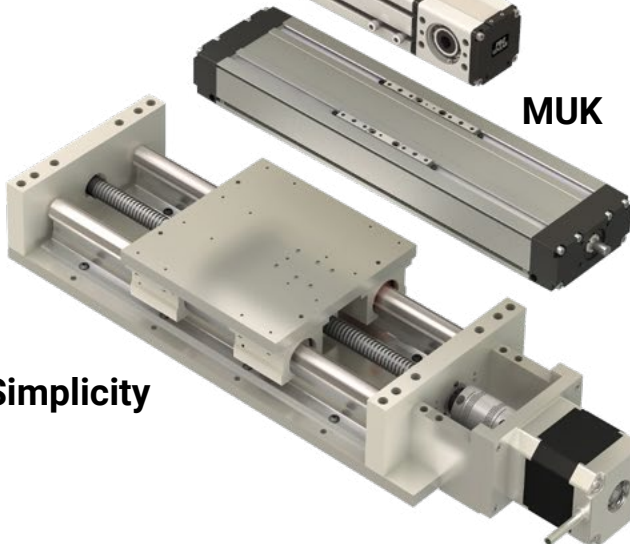

MUK

- Incorporates two 20 mm recirculating ball profile rail guideways
- Load capabilities up to 11200 N; maximum stroke = 1500 mm
- Single or dual carriage options available

Simplicity

Simplicity Linear Slides

- Handles heavy loads in harsh, contaminated environments
- Low profile systems for applications with height constraints
- Rail shaft diameters from 12.7 mm (0.5 in) to 50.8 mm (2.0 in)
- Rail lengths to 2440 mm (96 in)
- Carriage speeds up to 0.457 m/s (18 in/s)
- Normal carriage loads up to 83000 N (18750 lbf)



Global Footprint



📍 PBC Linear Worldwide Headquarters

6402 E. Rockton Road, Roscoe, Illinois 61073 USA
 Tel: +1.815.389.5600 • Toll-Free: +1.800.962.8979
 Fax: +1.815.389.5790
 sales@pbclinear.com • pbclinear.com

📍 PBC Linear Europe GmbH European Headquarters

Bonner Straße 363, 40589 Duesseldorf, Germany
 Tel: +49 211 545590 20 • Fax: +49 211 545590 39
 info@pbclinear.eu • pbclinear.eu

📍 PBC-MOONS China Headquarters

168 Mingjia Road, Minhang District, Shanghai 201107, P.R. China
 Tel: +86 21 52634688 • Fax: +86 21 52634098
 info@moons.com.cn • www.moons.com.cn

Range of Offerings



Request a FREE Product Sample



pbclinear.com/Contact-Us/Sample-Request

Distributed by

PBC Linear has a global network of distributors with thousands of locations worldwide.

Visit **pbclinear.com** to find a distributor near you.

All information within this catalog is correct at the time of printing. However, in some instances adjustments need to be made, and this may cause specific information to become outdated. For the most current version, please reference our online catalog through the resources menu at pbclinear.com.