

THE INFORMATION CONTAINED IN THIS DRAWING IS THE SOLE PROPERTY OF L-COM, INC. ANY REPRODUCTION IN PART OR WHOLE WITHOUT THE WRITTEN PERMISSION OF L-COM, INC. IS PROHIBITED.

REVISIONS			
REV	DESCRIPTION	DATE	APPROVED
A	INITIAL RELEASE	07/30/2019	MMARTINEZ

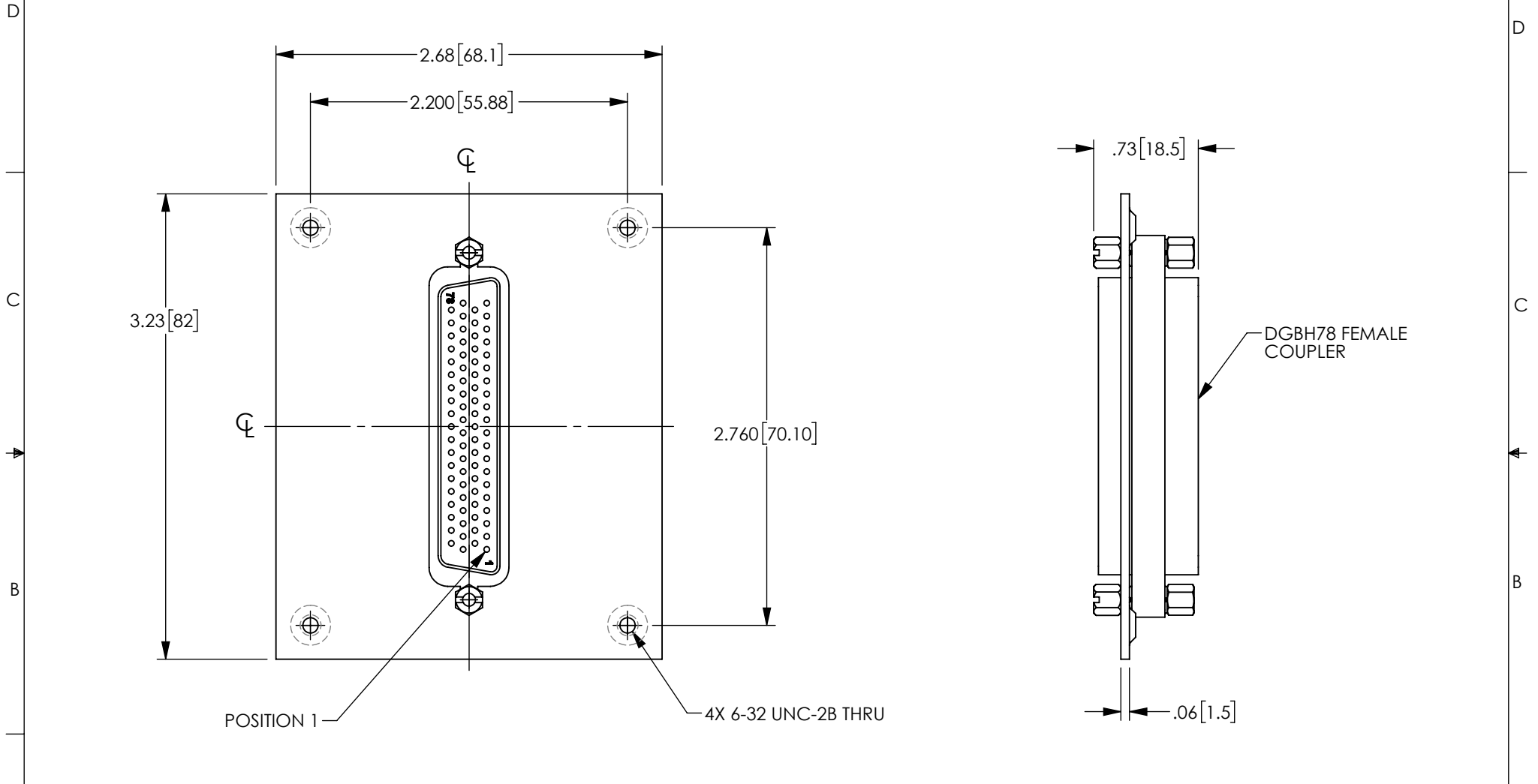

NOTES:

1. PANEL MATERIAL: .06 [1.5] THK COLD ROLLED STEEL.
2. PANEL FINISH: FLAT BLACK POWDER COAT.
3. KIT CONTAINS 4, #6-32 UNC SCREWS.
4. ALL DIMENSIONS SHOWN ARE FOR REFERENCE ONLY.

UNLESS OTHERWISE SPECIFIED, DIMENSIONS ARE IN INCHES [mm] DIMENSIONAL TOLERANCES: .X = ±.1 [2.54] .XX = ±.01 [.25] .XXX = ±.005 [.13] ANGULAR TOLERANCES: ALL = ± 1° PROJECTION 	APPROVALS DRAWN BY DZINN	DATE 07/30/2019	 an INFINITO brand	50 HIGH STREET NORTH ANDOVER, MA 01845
	CHECKED BY DFRISIELLO APPROVED BY MMARTINEZ	07/30/2019 07/30/2019		CATEGORY RACK/ENCLOSURES
	CONFIGURATION DETAILS OF UNDIMENSIONED FEATURES MAY VARY	PRODUCT DESCRIPTION USP PANEL 1 HD78 F-F		
	COLOR VARIATIONS MAY OCCUR	SIZE A	CAGE CODE 43321	DWG. NO. USP1HD78F

L-com (MA) 2019