

Type 41-2

Pressure Regulator Series

Features

- Superior regulation characteristics
- Rugged, corrosion-resistant construction
- Excellent stability and repeatability
- Self-relieving of excess downstream pressure
- Low droop at high flow
- Mounting options available

Description

Ruggedly designed and constructed, the Type 41 regulators have housings of precision-cast aluminum. They are pressure tested, and are chromate treated for internal corrosion resistance. Every regulator is finished with vinyl paint which resists scratching, weathering and other physical abuse.

Careful design and quality materials throughout assure long, trouble-free operation in the most difficult industrial environments. A rubberized, soft-seat valve stem provides stability and "forgives" dirt and other foreign matter. An aspirator maintains downstream pressure and compensates for droop when high flow occurs. The gauge port is convenient for gauge installation and can also be used as an additional full flow outlet.

The design of these regulators is especially well suited for panel applications due to ease of mounting (only one panel hole required), small size, adjustment sensitivity (32 threads per inch on the adjusting screw), and knob.

Models

Type 41-2

This unit comes standard with 1/4 NPT ports, a knob and a bonnet vent port which can be tapped for a 1/4 NPT fitting if desired. It can be panel mounted using either the center nut or the threaded shoulder holes, spaced 1.25 in. (32.7 mm) center-to-center.

Type 41-2 Dimensional Drawing

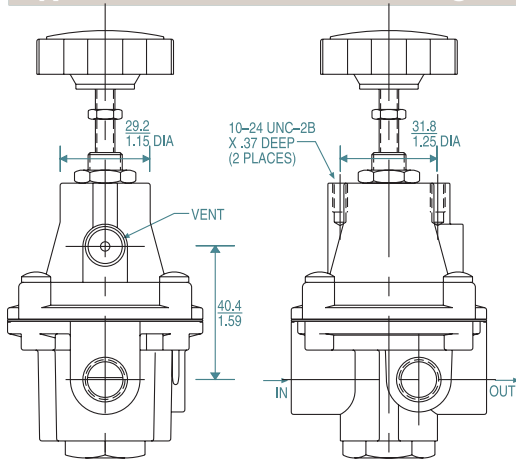

Optional Mounting Bracket

607-000-057

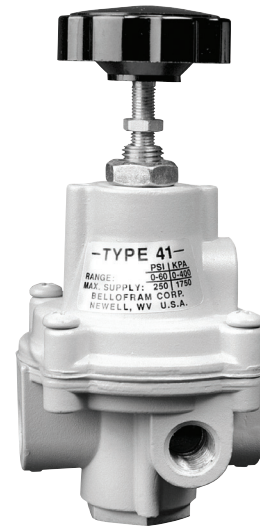
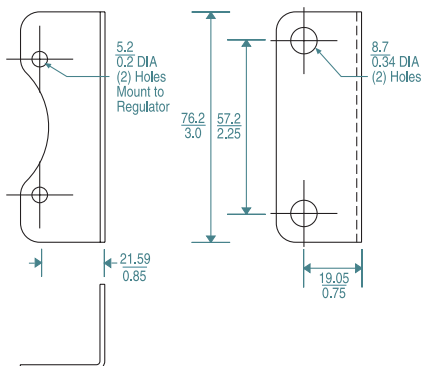

Type 41-2

Pressure Regulator Series

T41 Regulator Specifications

Sensitivity	1" Water Column (2.5 cm)
Flow Capacity @ 100 psig (6.9 BAR) Supply and 20 psig (1.4 BAR) outlet	25 SCFM (700 LPM)
Effect of Supply Pressure Variation (25 psig/1.7 BAR) on Outlet Pressure	±0.35 PSIG (24 mBAR)
Exhaust Capacity 5 psig (0.35 BAR) above 20 psig set point	0.1–0.45 SCFM Typical 2.8 - 12.7 LPM
Max Supply Pressure	250 PSIG (17.2 BAR)
Effect of Changes in Flow on Regulated Pressure (100 psig / 6.9 BAR Supply)	1 psig (0.07 BAR) over flow of 10 SCFM (0-30 psig / 0-2.1 BAR range, ¼ NPT, 20 psig / 1.4 BAR set point)
Output Pressure Ranges	0-2 PSIG (0-0.14 BAR) 0-10 PSIG (0-0.69 BAR) 0-30 PSIG (0-2.1 BAR) 0-60 PSIG (0-4.1 BAR) 0-100 PSIG (0-6.9 BAR)
Temperature Range	0-160°F (-18 to 71°C)
Total Air Consumption @ Maximum Output	6 SCFH (2.8 LPM)
Port Size	¼ NPT, BSPT
Materials of Construction	Body: Die cast aluminum with vinyl paint Adjusting Screw: Plated steel Trim: Plated steel, brass, acetal resin Diaphragm: Buna-N polyester fabric Knob: Phenolic Plastic Spring: Music wire
Mounting Options	Pipe, Panel or Bracket

Type 41: Regulated Pressure VS. Flow

