



**RoHS**  
COMPLIANT



# 174311.00 AND M1740007.00 DC DRIVE-1Q SCR-CHASSIS

The 174311.00 and M1740007.00 series of drives are a reliable and cost-effective solution for controlling your permanent magnet or shunt-wound DC motors in variable-speed applications. They use SCR's to provide full-wave rectification of the AC line input. This dual voltage drive operates using 115 VAC or 230 VAC, 50/60 Hz, to operate 90 or 180 VDC SCR brush-type motors from 1/20 to 2 HP. Packaged in a compact footprint, these user-friendly drives possess diagnostics and options to accommodate user needs.

## FEATURES

**Industry Standard Footprint** - Traditional mounting pattern and footprint allows for replacing competitive drives.

**Field Supply** - Voltage output to energize the field winding of a shunt-wound motor.

**Stopping Modes** - Inhibit (N.O.) for coasting to a stop. Can be used for frequent starting and stopping.

**Diagnostic LEDs** - Current Limit

# 174311.00 AND M1740007.00 DC DRIVE-1Q SCR-CHASSIS

## SPECIFICATIONS

- AC Line Voltage: 115 / 230 VAC,  $\pm 10\%$ , 50/60 Hz, 1 $\emptyset$
- Field Voltage **with 115 VAC Line (230 VAC Line):** 50/100 (100/200) VDC
- Maximum Field Amperage: 1 Amp
- Acceleration Time Range **with 90V Armature:** 0.5 - 11 seconds  
**with 180V Armature:** 0.5 - 22 seconds
- Deceleration Time Range **with 90V Armature:** coast to 13 seconds  
**with 180V Armature:** coast to 25 seconds
- Analog Signal Range **with 90V Armature:** 0 - 1.4 VDC
- **with 180V Armature:** 0 - 2.8 VDC Input
- Impedance (S1 to S2): >100K  $\Omega$
- Form Factor.: 1.37 at base speed
- Load Regulation: 1% of base speed or better
- Speed Range: 60:1
- Ambient Temperature Range: 10°C - 55°C

## ORDERING INFO

MODEL #	ENCLOSURE	MAXIMUM CURRENT (ADC)	INPUT VOLTAGE (VAC)	OUTPUT VOLTAGE (VDC)	POWER RANGE		FIELD/SHUNT SUPPLY (VDC)	BRAKING	REVERSING	ISOLATION
					HP	KW				
M1740007.00	CHASSIS	1.5	115	0-90	1/20-1/8	.04-.09	YES	NO	NO	NO
			230	0-90	1/20-1/8	.04-.09				
				0-180	1/10-1/4	.07-.19				
174311.00	CHASSIS	10*	115	0-90	1/8-1	.09-.75	YES	NO	NO	NO
			230	0-90	1/8-1	.09-.75				
				0-180	1/4-2	.19-1.5				

\* Heat sink kit 174314.00 must be used when the continuous output current is above 5 amps.

# 174311.00 AND M1740007.00 DC DRIVE-1Q SCR-CHASSIS

## DIMENSIONAL DRAWINGS — INCHES [MILLIMETERS]

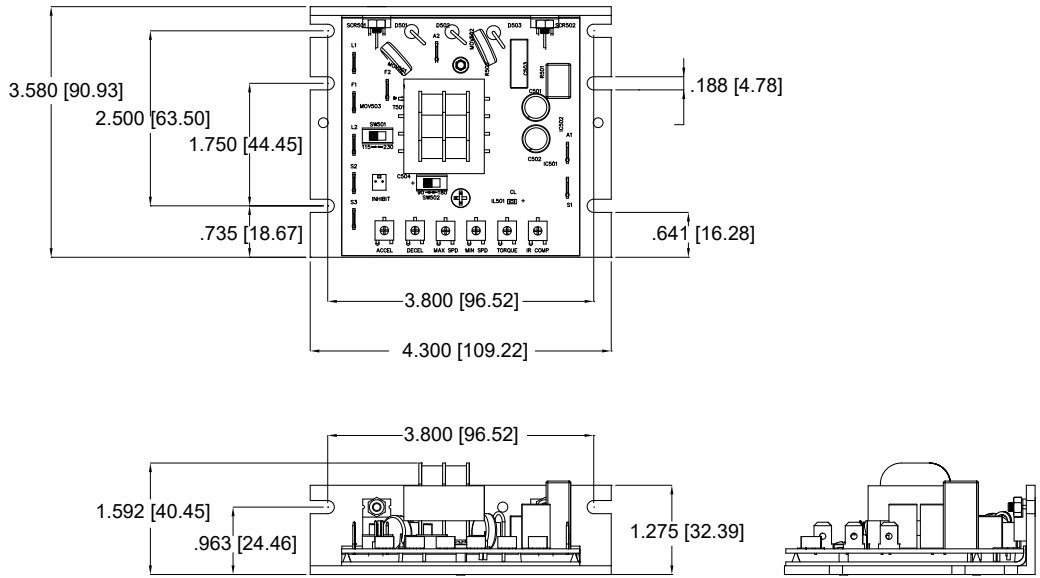

## WIRING

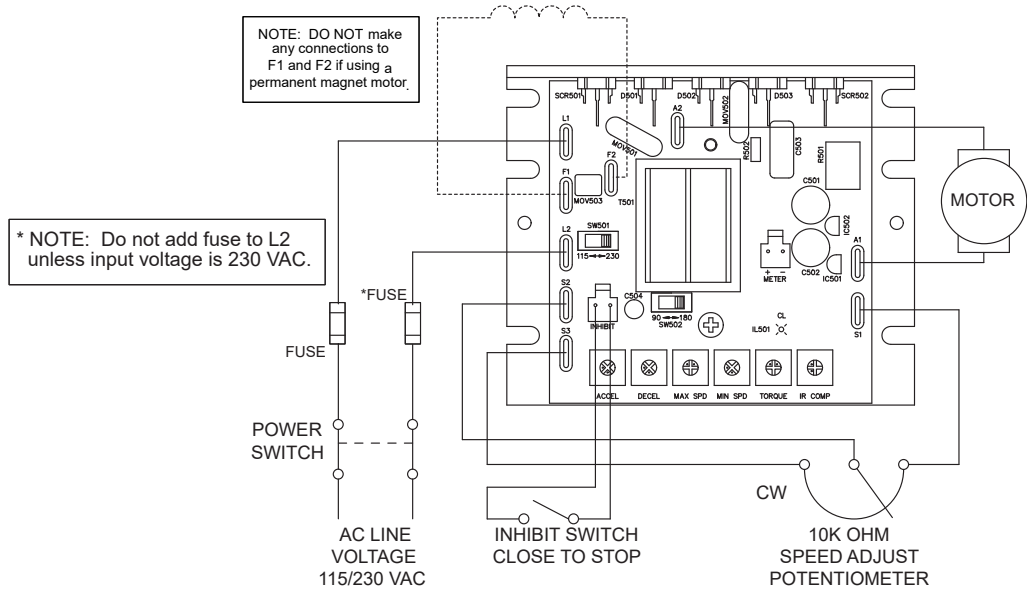

## TRIM POTS

- Acceleration
- IR Compensation
- Current Limit
- Maximum Speed Deceleration
- Minimum Speed

## ACCESSORIES

- 900282.01:** Inhibit Plug with 18" wire leads
- 006708.01:** Potentiometer kit (included with purchase of drive)
- 174314.00:** Heat sink

## GROWTH IS MUTUAL.

It's the result of decisions well made, and commitments perfectly executed. When we do things right, your growth is impacted as well. From solutions that save energy and money, to robust systems that keep you up and running, we'll anticipate your needs and deliver beyond your expectations. See what deep roots, a strong core product line, talented teams and a commitment to excellence can do for you. We invite you to grow with Regal.



**Regal Beloit America, Inc.**

1051 Cheyenne Avenue

Grafton, WI 53024

Customer Service: 262-377-8810

Fax: 262-377-9025

[www.regalbeloit.com](http://www.regalbeloit.com)

**APPLICATION CONSIDERATIONS**

The proper selection and application of power transmission products and components, including the related area of product safety, is the responsibility of the customer. Operating and performance requirements and potential associated issues will vary appreciably depending upon the use and application of such products and components. The scope of the technical and application information included in this publication is necessarily limited. Unusual operating environments and conditions, lubrication requirements, loading supports, and other factors can materially affect the application and operating results of the products and components and the customer should carefully review its requirements. Any technical advice or review furnished by Regal Beloit America, Inc. and/or its affiliates ("Regal") with respect to the use of products and components is given in good faith and without charge, and Regal assumes no obligation or liability for the advice given, or results obtained, all such advice and review being given and accepted at customer's risk.

For a copy of our Standard Terms and Conditions of Sale, please visit <http://www.regalbeloit.com> (please see link at bottom of page to "Standard Terms and Conditions of Sale"). These terms and conditions of sale, disclaimers and limitations of liability apply to any person who may buy, acquire or use a Regal product referred to herein, including any person who buys from a licensed distributor of these branded products.

Regal and Leeson are trademarks of Regal Beloit Corporation or one of its affiliated companies.

©2018 Regal Beloit Corporation, All Rights Reserved. MCSSP18041E • Form# L0042E

