



Every part matters

EN

Datasheet

RS Pro CLASS I Desktop

Power Supply 66JYH4Z-1800350-BY-RS

RS stock No.: 144-0978





Table of contents

1、 DESCRIPTION.....	3
2、 INPUT CHARACTERISTICS.....	3
3、 OUTPUT CHARACTERISTICS.....	3-4
4、 PROTECTION FUNCTION.....	4
5、 ENVIRONMENTAL REQUIREMET.....	4~5
6、 SAFETY AND EMC REQUIREMENT.....	5
7、 MECHANICAL REQUIREMENT.....	6
8、 CORD.....	7
9、 PACKING.....	7-8
10、 LABEL.....	8



1、 DESCRIPTION:

The purpose of the document is to specify the functional requirements of a 63W switching power supply.

2、 INPUT CHARACTERISTICS:

2.1 Input Voltage:

Rated Voltage:100~240Vac

Variation Range:90-264Vac

2.2 Input Frequency:

Rated Frequency: 50/60Hz.

Variation Frequency:47-63Hz

2.3 Input Current:

1.7Amps max At any input voltage and rated, DC output rated load.

2.4 Inrush Current:

120 Amps Max. Cold start at 240Vac input, with rated load and 25°C ambient.

2.5 AC Leakage Current:

0.25mA Max.At 240Vac input.

3、 OUTPUT CHARACTERISTICS:

3.1 Power output

Voltage	Min. Load	Rated. Load	Standby power	Output power
18Vdc	0A	3.5A	0.21W Max	63W



3.2 Combined Load/Line Regulation

Voltage	Min. Load	Rated. Load	Line Regulation	Load Regulation
18Vdc	0A	3.5A	±1%	±5%

3.3 Ripple and Noise:

Under nominal voltage and nominal load, the ripple and noise are as follows when measured with Max. Bandwidth of 20MHz and Parallel 47uF/0.1uF, crossed connected at testing point.

Voltage	Ripple and Noise(Max.)
+18Vdc	150mV p-p

3.4 Turn on delay time:

3Second Max. at 115Vac input and output Max. load.

3.5 Rise time:

40 mS Max. at 115Vac input and output Max. load.

3.6 Hold up time:

5 mS Min. at 115Vac input and output Max. Load.

3.7 Efficiency:

88% Min, At 115/230Vac input voltage, 1/4, 1/2, 3/4 and full load calculation average efficiency.

4. PROTECTION FUNCTION:

4.1 Short circuit test:

The power supply will be auto recovered when short circuit faults remove.

4.2 Over Voltage Protection:

The power supply will auto recovered when faults remove 120%~170%.

5. ENVIRONMENTAL REQUIREMENT:

5.1 Operating Temperature:

0°C to 40°C, Full load, Normal operation.

5.2 Storage Temperature: -20°C to 80°C (With package)

5.3 Relative Humidity:

5%(0°C)~90%(40°C)RH, 72Hrs, Full load, Normal operating.

5.4 Vibration:



1. Operating Standard: IEC 721-3-3 3M3

5~9Hz,A=1.5mm

9~200Hz,Acceleration 5m/S²

2. Transportation:

IEC 721-3-2 2M2

5-9Hz,A=3.5mm

9~200Hz,Acceleration=5m/S²

200~500Hz,Acceleration=15m/S²

3. Axes,10 cycles per axis.

No permanent damage may occur during testing.

The SAMPLE has to restore to its original situation after power off/on.

5.5 Dropping Packed:

1M for wallmount type and 760mm for desktop type as above described.

The horizontal surface consists of hardwood at least 13mm thick, mounted on two layers of plywood each 19mm to 20mm thick,all supported on a concrete or equivalent non-resilient floor.

6、 SAFETY REQUIREMENT:

6.1 DIELECTRIC STRENGTH Hi-Pot:

Primary to Secondary: 1800Vac / 3.5mA / 60 seconds(3 seconds for production)

or 2412Vdc / 3.5mA / 60 seconds(3 seconds for production)

6.2 Insulation resistance:

20MΩ min. at primary to secondary add a 500Vdc test voltage

6.3 Leakage Current

0.25mAmax. at 264Vac / 50Hz

6.4 Safety: accord with TUV/GS:EN62368-1,CB:IEC62368-1,UL/ CUL:UL/CSA62368-1

6.5 EMI STANDARD

Meets the Limits of

<1>.FCC part15 class B rules

<2>.EN55032,EN55024,EN55014,CLASS B rules

<3>.GB9254 CLASS B,

7、 MECHANICAL REQUIREMENT:

7.1 Enclosure: L120 x W52.5 x H36mm;The power supply size: L120 x W52.5 x H36mm;

7.2 Input Connector:IEC-320-C14.

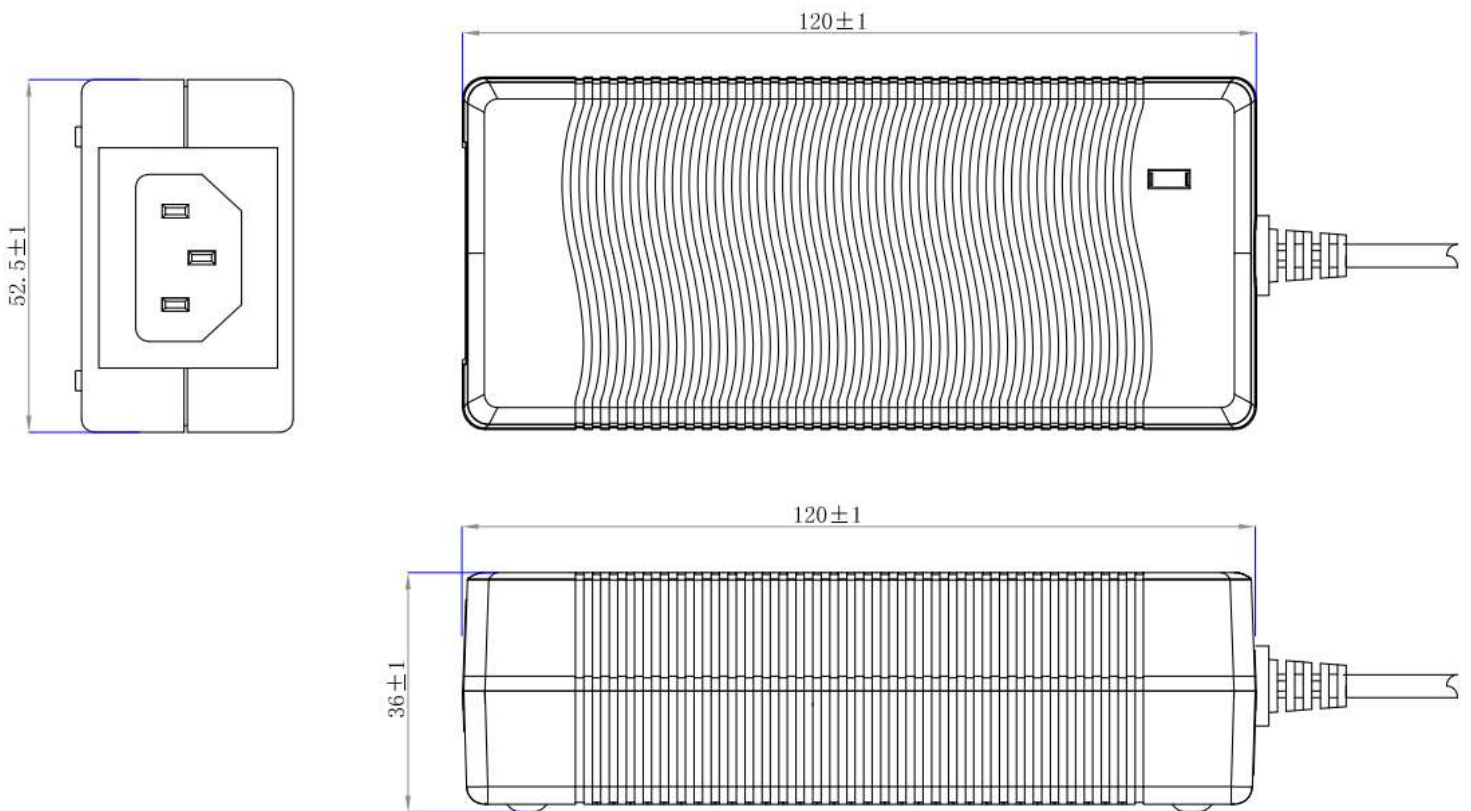

Material/材料:	<input checked="" type="checkbox"/> PC: 耐温 120°C/ temperature resistance 120°C&符合球压测试要求/ remark: PC texture
	<input type="checkbox"/> PC+ABS: 耐温 95°C/ temperature resistance 95°C
Fireproof Class/防火等级:	UL94V-0

8、CORD

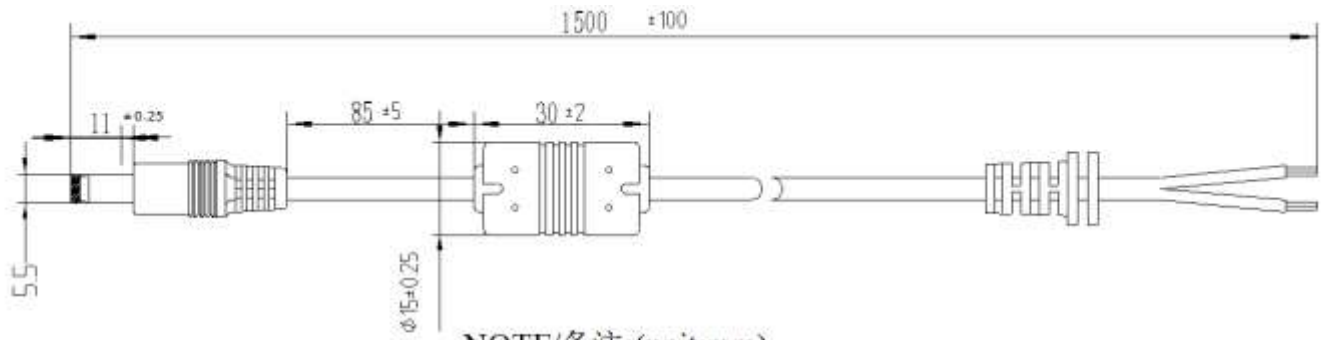

NOTE/备注:(unit:mm)

1.2464 20AWG 80 °C VW-1 300V L:1500±100mm

Material: 2464 20# Length: 1.5m

2.The polarity:inner-positive,outer-negative.

3.DC jack:5.5*2.1*11mm Fork style

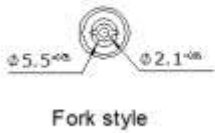

9、PACKING:

9.1 Carton:SIZE 415X370X170mm,50PCS/CTN,13.5KG/CTN

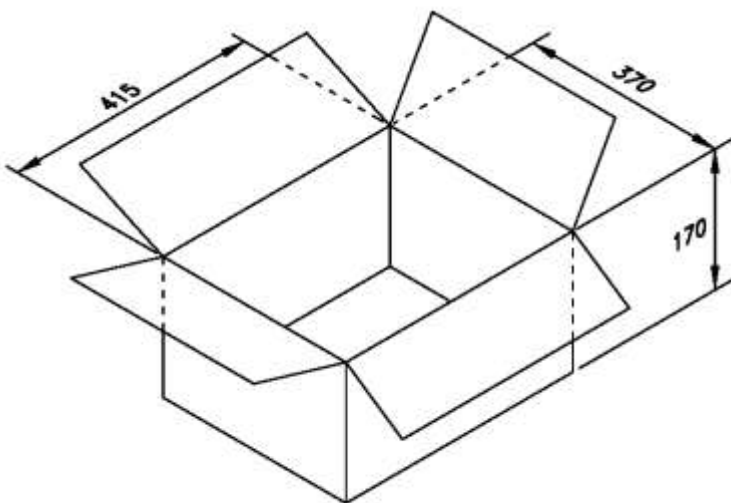

备注:

1.纸箱材质为A-B

抗张力14公斤/cm²

2.外箱尺寸为外部尺寸,公差为: +5,-0.

3.装箱方式: 以50pcs为一层,共装一层,共计
50PCS/箱

9.2 Inner box:

Small White Box with Barcode label

Outside box size :L*W*H:150*80*35mm

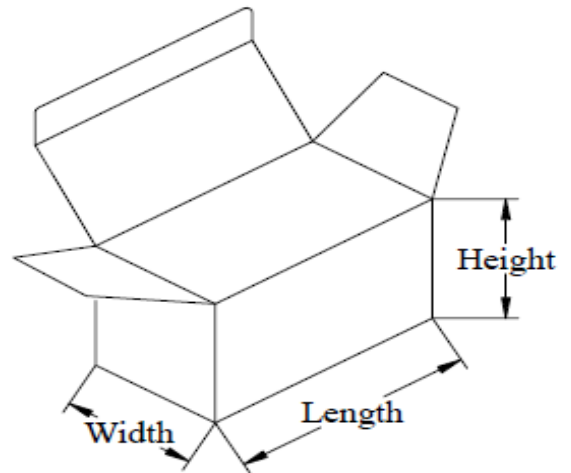

10、 LABEL:

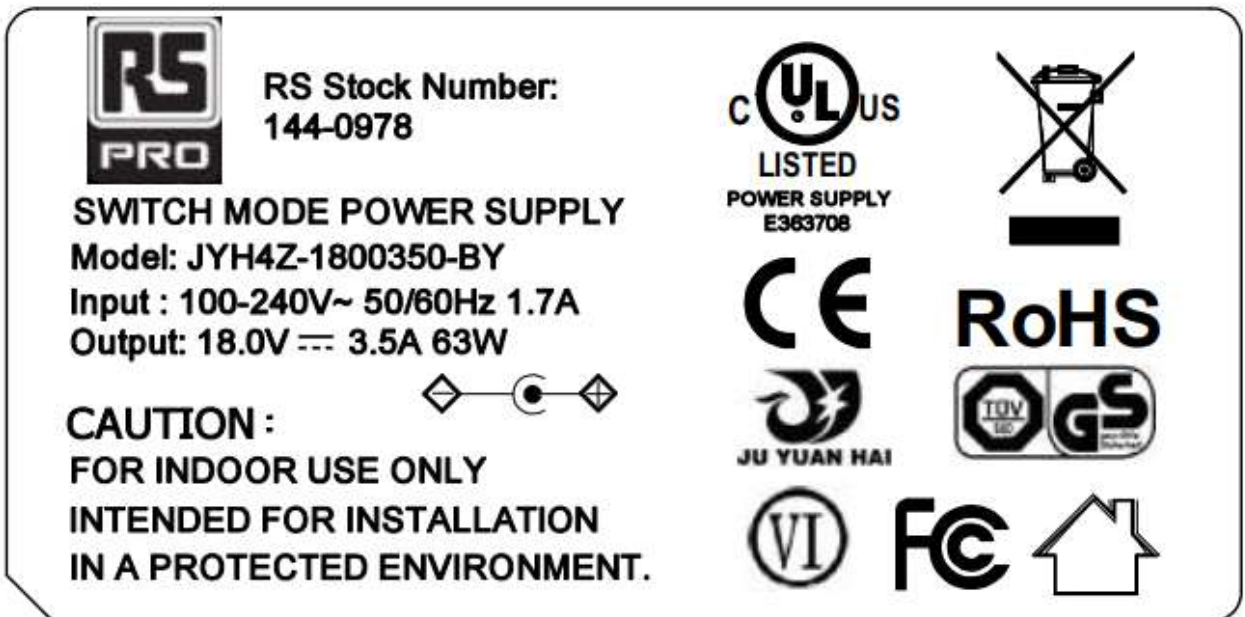

Note:The Specification be carved by Laser on Plastic housing.