

PREASSEMBLED HEATING CABLE

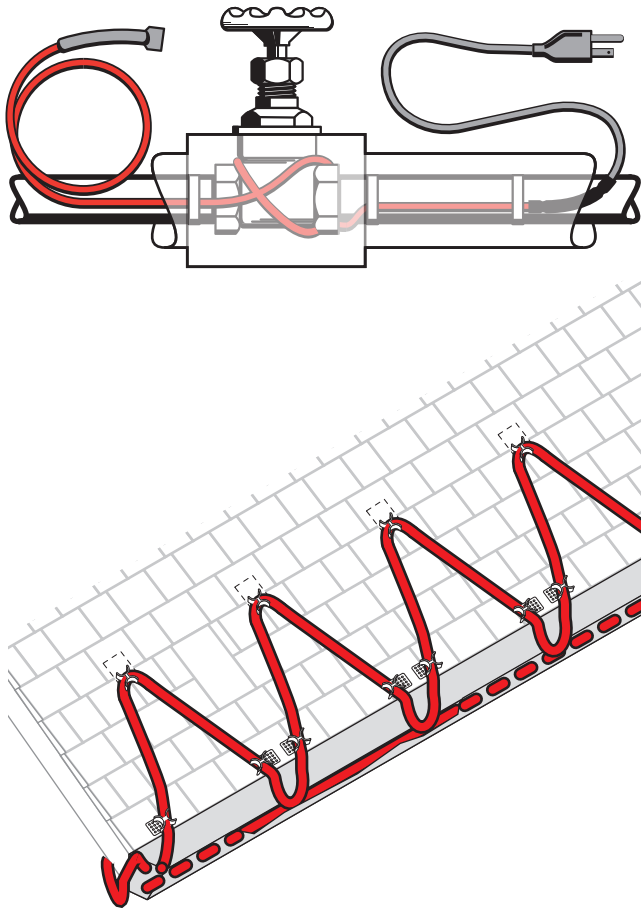

PRODUCT OVERVIEW

nVent RAYCHEM FrostGuard preassembled self-regulating heating cables are designed for residential and commercial metal and plastic pipe freeze protection and roof and gutter de-icing applications. 120 V FrostGuard cables are available in 6, 12, 18, 24, 36, 50, 75 and 100 foot lengths, and each comes assembled with a 6-ft power cord and 3-prong, grounded, lighted plug to show the system is on. 120 V FrostGuard cables are ideal for smaller jobs such as roof and gutter de-icing on porches and overhangs, as well as for pipe freeze protection on metal or plastic pipes up to 2-1/2 inches in diameter.

240 V FrostGuard cables are available in 6, 12, 18, and 24 foot lengths and each come assembled with a 6-ft power cord for terminating in a junction box. Due to their short lengths, 240 V FrostGuard cables are designed only for pipe freeze protection applications on pipes up to 2-1/2 inches in diameter.

FROSTGUARD PREASSEMBLED HEATING CABLE SPECIFICATIONS

Catalog number	120 V with 6-ft cold lead & lighted plug	208-240 V with 6-ft cold lead
	FG1-6P	FG2-6L
	FG1-12P	FG2-12L
	FG1-18P	FG2-18L
	FG1-24P	FG2-24L
	FG1-36P	
	FG1-50P	
	FG1-75P	
	FG1-100P	

FROSTGUARD PREASSEMBLED HEATING CABLE SPECIFICATIONS

Application	Pipe freeze protection and roof and gutter de-icing	Pipe freeze protection
Voltage	120 V	208-240 V
Nominal power output on pipes at 40°F (5°C) (W/ft)	6	6
Nominal power output in ice or snow at 32°F (W/ft)	8	N/A
Maximum cable width (inch/mm)	0.45 (11.4)	0.45 (11.4)
Maximum cable thickness (inch/mm)	0.24 (6.1)	0.24 (6.1)
Cold lead length (ft/m)	6 (1.83)	6 (1.83)
Maximum exposure temperature	150°F (65°C)	150°F (65°C)
Minimum installation temperature	5°F (-15°C)	5°F (-15°C)
Minimum bend radius (inch/mm)	5/8 (16)	5/8 (16)

APPROVALS



GROUND-FAULT PROTECTION

To minimize the danger of fire from sustained electrical arcing if the heating cable is damaged or improperly installed, and to comply with the requirements of nVent, agency certifications, and national electrical codes, 30-mA equipment or 5-mA personnel ground-fault protection must be used on each FrostGuard heating cable branch circuit. Arcing may not be stopped by conventional circuit protection.

NOMINAL POWER TEMPERATURE CURVE FOR PIPES

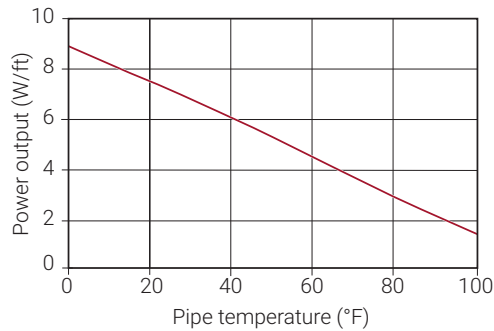

HEATING CABLE SELECTION FOR PIPE FREEZE PROTECTION

Pipe freeze protection

Use the tables to below to select the correct heating cable length.

FrostGuard 120 V (FG1) Heating Cable Selection

Table 1 Metal Pipes

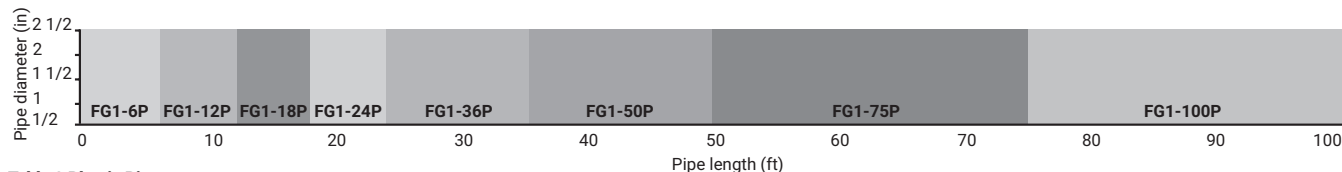
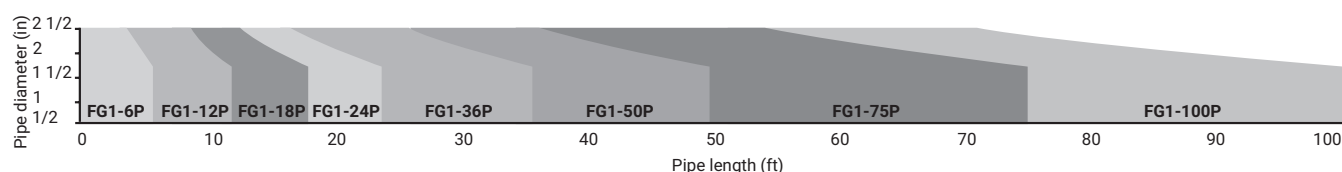

Table 2 Plastic Pipes



Add 1 foot to your pipe length for each valve or spigot on your pipe system. If cable selected is longer than the pipe, spiral it evenly along the entire pipe.

FROSTGUARD 240 V (FG2) HEATING CABLE SELECTION

Table 1 Metal Pipes

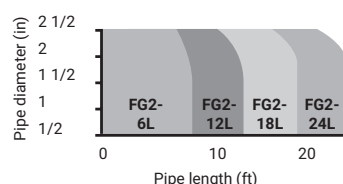
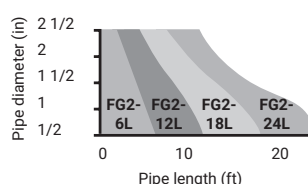

Table 2 Plastic Pipes



Add 1 foot to your pipe length for each valve or spigot on your pipe system. If cable selected is longer than the pipe, spiral it evenly along the entire pipe.

HEATING CABLE SELECTION FOR ROOF AND GUTTER DE-ICING (120 V ONLY)

Find the number of feet of heating cable needed per foot of roof edge in table to the right. Then, calculate the amount of total heating cable length you need using the following formula:

$$\text{Length} = A + B + C + D$$

- A Roof edge length (ft) x Length of cable per foot of roof edge (ft)
- B Roof edge (ft) x 0.5*
- C Total gutter length (ft)
- D Total downspout length (ft) + 1 (ft) [double if looping]
- = Total heating cable length (ft)

*Roof extension: This length allows the heating cable to extend into the gutter to provide a continuous drain path, or where no gutters are present, extends beyond the roof edge to form a drip loop.

Length of Cable Per Foot of Roof Edge (ft)	Standing Seam Metal Roof			
	Overhang (in)	Standard Roof	18 inch Seam	24 inch Seam
None*		2	2.5	2
12 in		2.8	2.8	2.4
24 in		3.8	3.6	2.9
36 in		4.8	4.3	3.6

* Gutter required

Note: nVent recommends a gutter and downspouts to provide a continuous path for melted water.

- If downspout is in the middle of the run, loop the FrostGuard down and back up. Double the length of the downspout for determining the length of FrostGuard to install.
- For valleys, run the heating cable two thirds of the way up and down the valley.
- For gutters 5-6 inches wide, use 2 runs of heating cable.
- For gutters wider than 6 inches contact nVent, (800) 545-6258.

North America

Tel +1.800.545.6258

Fax +1.800.527.5703

thermal.info@nvent.com



nVent.com

Our powerful portfolio of brands:

CADDY ERICO HOFFMAN RAYCHEM SCHROFF TRACER

Raychem FrostGuard 240 V

240 V PREASSEMBLED ELECTRIC HEATING CABLES FOR PIPE FREEZE PROTECTION

INSTALLATION INSTRUCTIONS

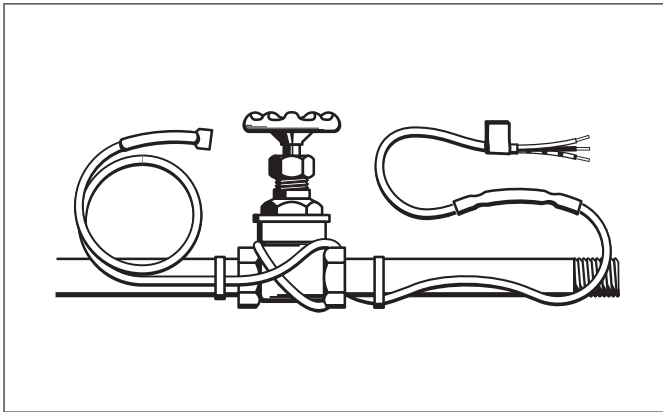

DESCRIPTION

FrostGuard 240 V preassembled electric heating cables are intended for installation on metal or plastic water pipes for freeze protection in commercial locations. FrostGuard 240 V heating cables are available in 6-, 12-, 18-, and 24-foot lengths and each comes complete with a 6-ft cold lead.

KIT CONTENTS

Item	Qty	Description
1		FrostGuard preassembled heating cable
3		Wire connectors

ADDITIONAL MATERIALS REQUIRED

- 1 UL Listed or CSA Certified junction box suitable for wet or dry areas
- 1 UL Listed or CSA Certified outlet bushing and fitting
- Cable ties or glass-cloth tape
- Thermal pipe insulation

APPROVALS



HEATING CABLE SELECTION

FrostGuard 240 V (FG2) heating cable selection for pipe freeze protection:

Use the tables to the right to select the correct heating cable. Round up to the next pipe size if your pipe diameter isn't shown.

The charts assume the lowest ambient temperature is -20°F (-29°C), with a minimum of 1/2 in fiberglass insulation or equivalent. For protection to -40°F (-40°C), use 1 inch fiberglass insulation or equivalent fire-resistant insulation.

Add 1 foot to your pipe length for each valve or spigot on your pipe system. If length of cable selected is longer than the pipe, spiral it evenly along the entire pipe.

Table 1 Metal Pipes

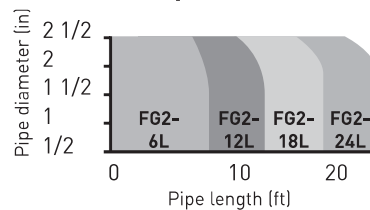
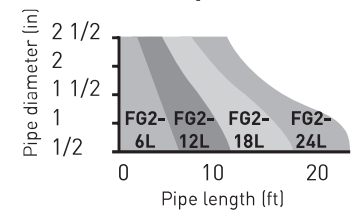

Table 2 Plastic Pipes



Add 1 foot to your pipe length for each valve or spigot on your pipe system. If cable selected is longer than the pipe, spiral it evenly along the entire pipe.

Important

All thermal and design information provided here is based upon a "standard installation": heating cable fastened to a pipe and thermally insulated. For any other method of installation or application, consult Pentair Thermal Building Solutions at (800) 542-8936 for design assistance to ensure proper design of electrical distribution and acceptable pipe temperatures.

WARNING:

FIRE AND SHOCK HAZARD. This product is an electrical device that must be installed correctly to ensure proper operation and to prevent shock or fire. Read these important warnings and carefully follow all the installation instructions.

- To minimize the danger of fire from sustained electrical arcing if the heating cable is damaged or improperly installed, and to comply with the requirements of Pentair Thermal Building Solutions, agency certifications, and the National Electrical Code, ground-fault equipment protection must be used on each heating cable branch circuit. Arcing may not be stopped by conventional circuit protection.
- Use only fire-resistant insulation materials such as fiberglass wrap.
- Do not damage the heating cable and cord connector. Remove any damaged cables from service immediately.
- Do not use any wire or metal clamps to attach the cable to the pipe. Use tape (1/2 inch wide to 1 inch wide) or plastic cable ties.
- Leave these installation instructions with the user for future reference.

GENERAL REQUIREMENTS:

- FrostGuard heating cables are not intended for use inside any pipes, for freeze protection of liquids other than water, or for use in classified hazardous locations.
- FrostGuard heating cables may be used on metal and plastic water pipes but not on flexible vinyl tubing (such as garden hoses).
- Install with a minimum of 1/2 inch fire-resistant thermal insulation. Weatherproof the insulation if it might get wet.
- Never use on any pipes that may exceed 150°F (65°C).

GENERAL INSTRUCTIONS:

- Install only in accessible locations; do not install behind walls or where the cable would be hidden.
- Do not run the heating cable through walls, ceilings, or floors.
- Connect only to junction boxes that have been installed in accordance with all prevailing national and local codes and standards and are protected from rain and other water.
- Prior to installing the cable, remove any sharp surfaces on the pipe that might damage the heating cable.
- Follow the specific installation instructions that begin below.
- Follow the maintenance guidelines on page 3.

1

Side View

1a Spiral traced

1b Straight traced

End View

1c Two cables in 4 and 8 o'clock positions

1d Three cables in 4, 8, and 10 o'clock positions

- If your FrostGuard cable is longer than the pipe, spiral it evenly along the pipe (Figure 1a).
- If your FrostGuard cable is the same length as the pipe, run it straight along the pipe (Figure 1b) in the 4 o'clock or 8 o'clock position.
- If two FrostGuard cables are used, position them in the 4 o'clock and 8 o'clock positions (Figure 1c).
- If three FrostGuard cables are used, position them in the 4, 8, and 10 (or 2) o'clock positions (Figure 1d).

2

Spiral-traced Installation

Straight-traced Installation

- Fasten the cable to the pipe at 12-inch intervals with glass cloth tape or plastic cable ties. If excess cable remains at the end of the pipe, double it back along the pipe and cover it with insulation.
- Provide extra heat at valves and spigots by wrapping each with an additional foot of heating cable, overlapping as required.

3

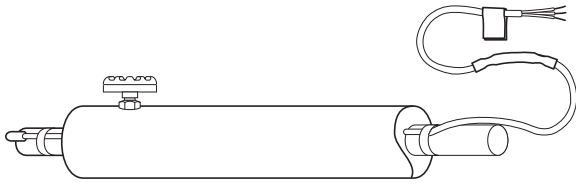

Thermal insulation

- Before installing the thermal insulation, check to see that the heating cable is free from mechanical damage (such as from cuts or clamps) and thermal damage (such as from solder or overheating).
- Using a megohmmeter, test each circuit according to the "Cable testing and maintenance" instructions below, both prior to and after installing the thermal insulation.

Note: A reliable FrostGuard system depends on properly installed and dry, weatherproofed thermal insulation.

- Ensure that at least 1/2 inch of fiberglass or equivalent thermal insulation is used and that all pipework, including valves, joints, and wall penetrations, has been fully insulated. To minimize the potential for mechanical damage after installation, install the insulation on the pipework as soon as possible.
- Be sure the FrostGuard 240 V label is visible on the outside of the thermal insulation.

4

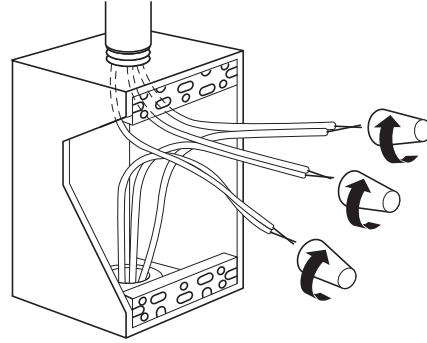

Connecting the FrostGuard cable to power

Using the three wire connectors included in the kit, connect the black and white cold leads to both phase wires and the green cold lead to ground. Provide suitable UL Listed and CSA Certified junction box and outlet bushing and fitting.

CABLE TESTING AND MAINTENANCE

Using a 2500-Vdc megohmmeter, check the insulation resistance between the lead wires and ground wire during installation. Minimum reading should be 1000 megohms.

The installer should record the original values for each circuit. Subsequent readings taken during regular maintenance schedules should be compared to the original value.

If the readings should fall below 1000 megohms, replace the FrostGuard cable with a new unit. Do not attempt to repair the unit.



WARNING: Fire and Shock Hazard. Damaged heating cable can cause electrical shock, arcing, or fire. Do not attempt to repair or energize damaged heating cable. Remove it at once and replace with a new length.

Product Specifications

	FG2-6L	FG2-12L	FG2-18L	FG2-24L
Cable length (ft/m)	6 (1.8)	12 (3.7)	18 (5.5)	24 (7.3)
Min. thermal output on a pipe at 40°F/4°C (watts)	30	60	90	120
Min. thermal output on a pipe at 0°F/-18°C (watts)	46	92	138	184
Max. current draw on a pipe at 40°F/4°C (amps)	0.21	0.43	0.64	0.85
Max. current draw on a pipe at 0°F/-18°C (amps)	0.32	0.64	0.96	1.28

General Specifications for all FG2 Products

Maximum cable width (inch/mm)	0.45 (11.4)
Maximum cable thickness (inch/mm)	0.24 (6.1)
Heating cable bus wire gauge (AWG)	16
Voltage rating (Vac)	208-240
Circuit breaker size	15 A max.
Cold lead length (ft/m)	6 (1.83)
Maximum exposure temperature	150°F (65°C)
Minimum installation temperature	5°F (-15°C)
Maximum bend radius (inch/mm)	5/8 (16)
Electrical classification	Nonhazardous areas only
Exposure to chemicals	None



WWW.PENTAIRTHERMAL.COM

NORTH AMERICA

Tel: +1.800.545.6258
Fax: +1.800.527.5703
Tel: +1.650.216.1526
Fax: +1.650.474.7711
thermal.info@pentair.com

Pentair and FrostGuard are owned by Pentair or its global affiliates. All other trademarks are the property of their respective owners. Pentair reserves the right to change specifications without prior notice.

©2016 Pentair.