

PREASSEMBLED HEATING CABLE

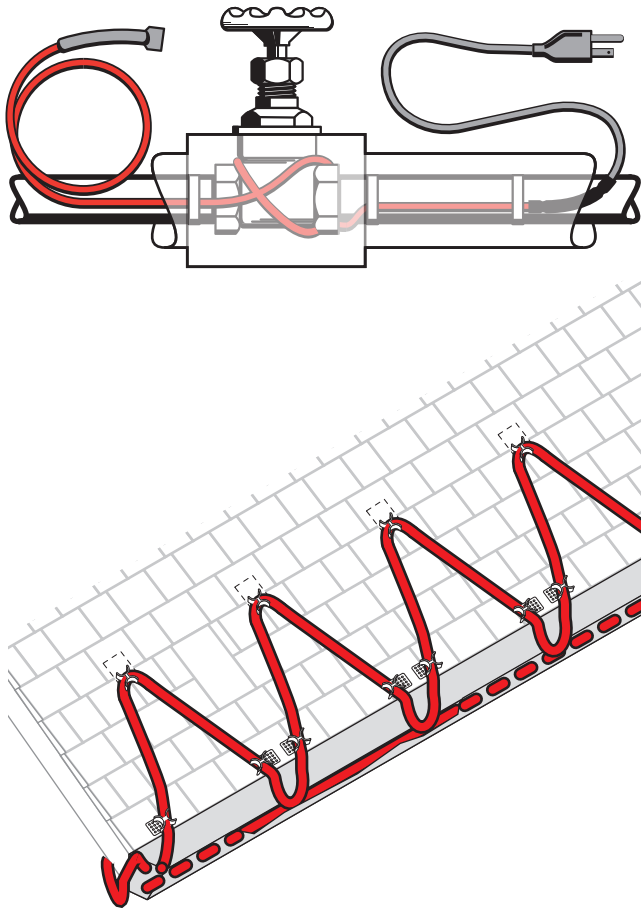

PRODUCT OVERVIEW

nVent RAYCHEM FrostGuard preassembled self-regulating heating cables are designed for residential and commercial metal and plastic pipe freeze protection and roof and gutter de-icing applications. 120 V FrostGuard cables are available in 6, 12, 18, 24, 36, 50, 75 and 100 foot lengths, and each comes assembled with a 6-ft power cord and 3-prong, grounded, lighted plug to show the system is on. 120 V FrostGuard cables are ideal for smaller jobs such as roof and gutter de-icing on porches and overhangs, as well as for pipe freeze protection on metal or plastic pipes up to 2-1/2 inches in diameter.

240 V FrostGuard cables are available in 6, 12, 18, and 24 foot lengths and each come assembled with a 6-ft power cord for terminating in a junction box. Due to their short lengths, 240 V FrostGuard cables are designed only for pipe freeze protection applications on pipes up to 2-1/2 inches in diameter.

FROSTGUARD PREASSEMBLED HEATING CABLE SPECIFICATIONS

Catalog number	120 V with 6-ft cold lead & lighted plug	208-240 V with 6-ft cold lead
	FG1-6P	FG2-6L
	FG1-12P	FG2-12L
	FG1-18P	FG2-18L
	FG1-24P	FG2-24L
	FG1-36P	
	FG1-50P	
	FG1-75P	
	FG1-100P	

FROSTGUARD PREASSEMBLED HEATING CABLE SPECIFICATIONS

Application	Pipe freeze protection and roof and gutter de-icing	Pipe freeze protection
Voltage	120 V	208-240 V
Nominal power output on pipes at 40°F (5°C) (W/ft)	6	6
Nominal power output in ice or snow at 32°F (W/ft)	8	N/A
Maximum cable width (inch/mm)	0.45 (11.4)	0.45 (11.4)
Maximum cable thickness (inch/mm)	0.24 (6.1)	0.24 (6.1)
Cold lead length (ft/m)	6 (1.83)	6 (1.83)
Maximum exposure temperature	150°F (65°C)	150°F (65°C)
Minimum installation temperature	5°F (-15°C)	5°F (-15°C)
Minimum bend radius (inch/mm)	5/8 (16)	5/8 (16)

APPROVALS



GROUND-FAULT PROTECTION

To minimize the danger of fire from sustained electrical arcing if the heating cable is damaged or improperly installed, and to comply with the requirements of nVent, agency certifications, and national electrical codes, 30-mA equipment or 5-mA personnel ground-fault protection must be used on each FrostGuard heating cable branch circuit. Arcing may not be stopped by conventional circuit protection.

NOMINAL POWER TEMPERATURE CURVE FOR PIPES

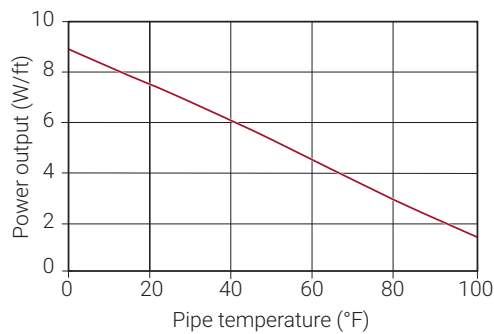

HEATING CABLE SELECTION FOR PIPE FREEZE PROTECTION

Pipe freeze protection

Use the tables to below to select the correct heating cable length.

FrostGuard 120 V (FG1) Heating Cable Selection

Table 1 Metal Pipes

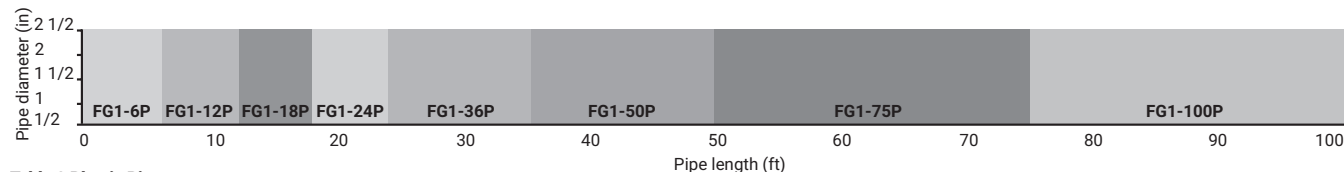
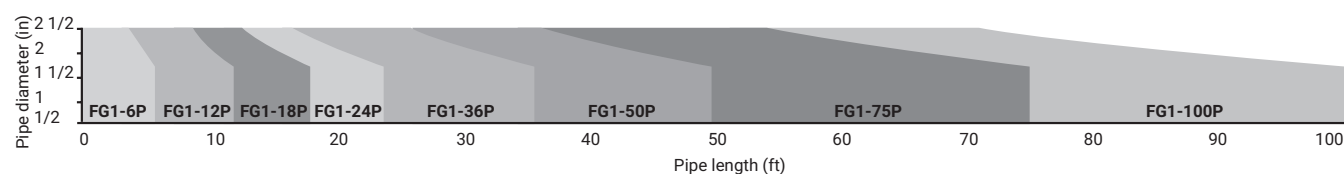

Table 2 Plastic Pipes



Add 1 foot to your pipe length for each valve or spigot on your pipe system. If cable selected is longer than the pipe, spiral it evenly along the entire pipe.

FROSTGUARD 240 V (FG2) HEATING CABLE SELECTION

Table 1 Metal Pipes

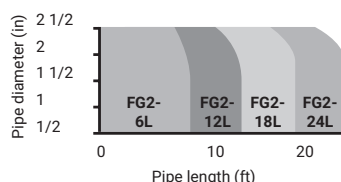
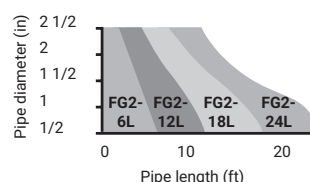

Table 2 Plastic Pipes



Add 1 foot to your pipe length for each valve or spigot on your pipe system. If cable selected is longer than the pipe, spiral it evenly along the entire pipe.

HEATING CABLE SELECTION FOR ROOF AND GUTTER DE-ICING (120 V ONLY)

Find the number of feet of heating cable needed per foot of roof edge in table to the right. Then, calculate the amount of total heating cable length you need using the following formula:

$$\text{Length} = A + B + C + D$$

- A Roof edge length (ft) x Length of cable per foot of roof edge (ft)
- B Roof edge (ft) x 0.5*
- C Total gutter length (ft)
- D Total downspout length (ft) + 1 (ft) [double if looping]
- = Total heating cable length (ft)

*Roof extension: This length allows the heating cable to extend into the gutter to provide a continuous drain path, or where no gutters are present, extends beyond the roof edge to form a drip loop.

Length of Cable Per Foot of Roof Edge (ft)	Standing Seam Metal Roof			
	Overhang (in)	Standard Roof	18 inch Seam	24 inch Seam
None*		2	2.5	2
12 in		2.8	2.8	2.4
24 in		3.8	3.6	2.9
36 in		4.8	4.3	3.6

* Gutter required

Note: nVent recommends a gutter and downspouts to provide a continuous path for melted water.

- If downspout is in the middle of the run, loop the FrostGuard down and back up. Double the length of the downspout for determining the length of FrostGuard to install.
- For valleys, run the heating cable two thirds of the way up and down the valley.
- For gutters 5-6 inches wide, use 2 runs of heating cable.
- For gutters wider than 6 inches contact nVent, (800) 545-6258.

North America

Tel +1.800.545.6258

Fax +1.800.527.5703

thermal.info@nvent.com



nVent.com

Our powerful portfolio of brands:

CADDY ERICO HOFFMAN RAYCHEM SCHROFF TRACER



RAYCHEM

FROSTGUARD 120 V

120 V Preassembled Electric Heating Cables for Pipe Freeze Protection and Roof & Gutter De-Icing Installation Instructions

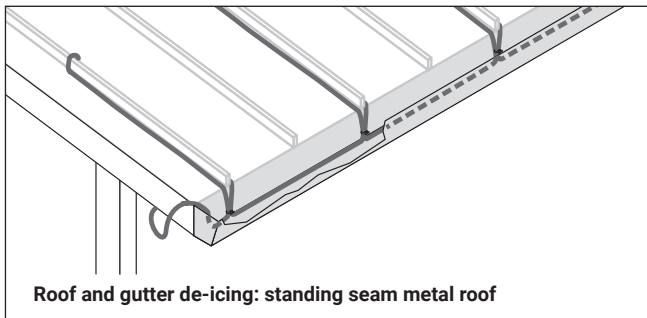
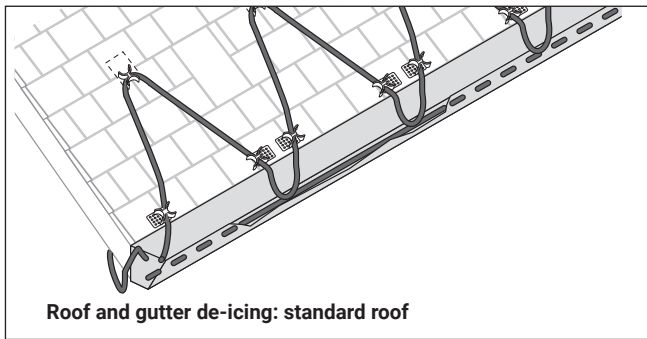
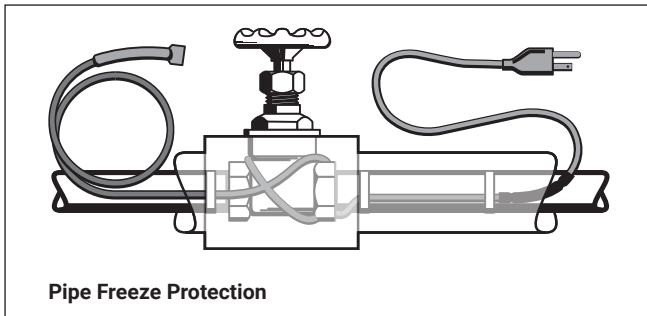

DESCRIPTION

nVent RAYCHEM FrostGuard 120 V preassembled self-regulating heating cables are designed for residential and light commercial metal and plastic pipe freeze protection and roof & gutter de-icing applications. FrostGuard 120 V heating cables are available in 6, 12, 18, 24, 36, 50, 75 and 100 foot lengths, and each comes assembled with a 6-ft power cord and lighted plug.

KIT CONTENTS

- 1 FrostGuard preassembled electric heating cable
- 2 Roof and gutter labels
- 2 Pipe labels

ADDITIONAL ITEMS REQUIRED BUT NOT SUPPLIED FOR PIPE APPLICATIONS

- Ground-fault protected outlet (GFCI)
- Waterproof thermal insulation (e.g. preformed foam)
- RAYCHEM H903 Application Tape and Electric Traced Labels

ADDITIONAL ITEMS REQUIRED BUT NOT SUPPLIED FOR ROOF & GUTTER APPLICATIONS

- RAYCHEM H913/H914 Roof Clips (10 clips for each 7 linear feet of roof edge)
- RAYCHEM H915 Hanger Bracket (1 for each downspout, 2 if looping)
- UV Resistant cable ties
- Ground-fault protected outlet (GFCI)

APPROVALS



WARNING:

Fire and Shock Hazard. This product is an electrical device that must be installed correctly to ensure proper operation and to prevent shock or fire. Read these important warnings and carefully follow all the installation instructions.

- To minimize the danger of fire from sustained electrical arcing if the heating cable is damaged or improperly installed, and to comply with the requirements of nVent agency certifications, and national electrical

codes, ground-fault equipment protection must be used on each heating cable branch circuit. Arcing may not be stopped by conventional circuit protection.

- For pipe freeze protection applications, use only fire-resistant insulation materials such as preformed foam or fiberglass.
- Do not damage the heating cable and power cord or plug. Remove any damaged cables from service immediately.

- Do not use any wire or metal clamps to attach the cable to the pipe. Use tape (1/2 inch wide to 1 inch wide) or plastic cable ties.
- Do not install the heating cable underneath any roof covering for roof and gutter de-icing.
- Leave these installation instructions with the user for future reference.

Pipe Freeze Protection

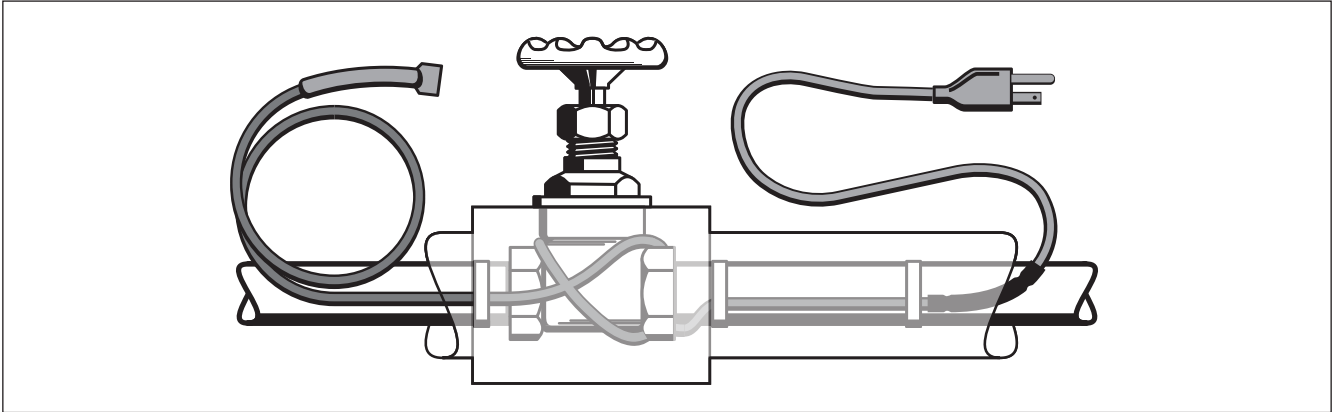

General requirements for pipe freeze protection:

- FrostGuard heating cables may be used on metal and plastic water pipes but not on flexible vinyl tubing (such as garden hoses).
- FrostGuard heating cables are not intended for use inside any pipes, for freeze protection of liquids other than water, or for use in classified hazardous locations.
- Install with a minimum of 1/2" fire-resistant, waterproof thermal insulation.
- Never use on any pipes that may exceed 150°F (65°C).
- Do not use an extension cord.

General instructions:

- Install only in accessible locations; do not install behind walls or where the cable would be hidden.
- Do not run the heating cable through walls, ceilings, or floors.
- Connect only to ground-fault protected outlets that have been installed in accordance with all prevailing national and local codes and standards and are protected from rain and other water.

Electrical codes

Articles 422 and 427 of the National Electrical Code (NEC), and Part 1, Section 62 of the Canadian Electrical Code (CEC), govern the installation of FrostGuard heating cable for pipe freeze protection and must be followed.

Important: For the nVent warranty to be valid, you must comply with all the requirements outlined in these guidelines.

All thermal and design information provided here is based upon a "standard" installation with heating cable fastened to an insulated pipe. For any other application or method of installation, consult nVent at (800) 545-6258

FrostGuard 120 V (FG1) heating cable selection for pipe freeze protection:

Use the tables below to select the correct heating cable. Add 1 foot to your pipe length for each valve or spigot on your pipe system.

The charts assume the lowest outside temperature is 0°F (-18°C), with a minimum of 1/2" thick waterproof, fire-resistant thermal insulation (preformed foam). For protection to -20°F (-29°C), use 1" thick insulation.

Important: All thermal and design information provided here is based upon a "standard installation": heating cable fastened to a pipe and thermally insulated. For any other method of installation or application, consult nVent at (800) 545-6258.

Table 1 Metal Pipes

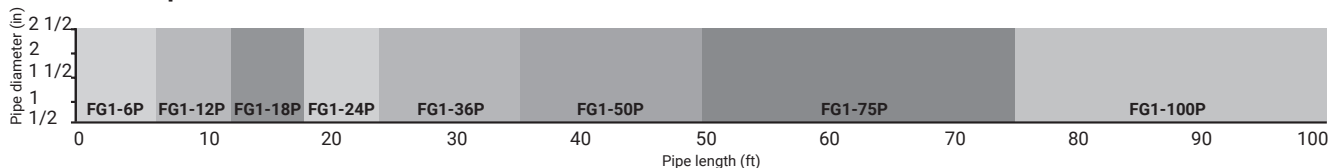
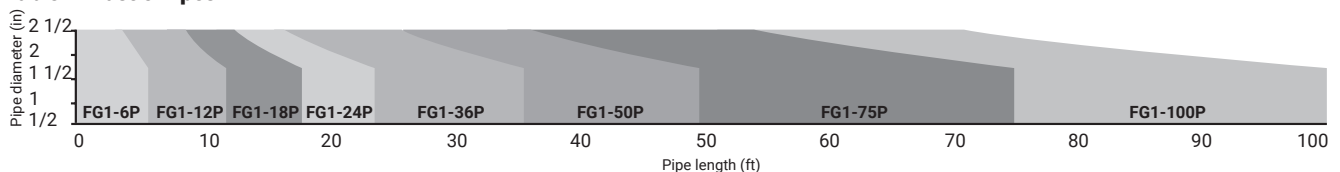

Table 2 Plastic Pipes



Add 1 foot to your pipe length for each valve or spigot on your pipe system. If cable selected is longer than the pipe, spiral it evenly along the entire pipe.

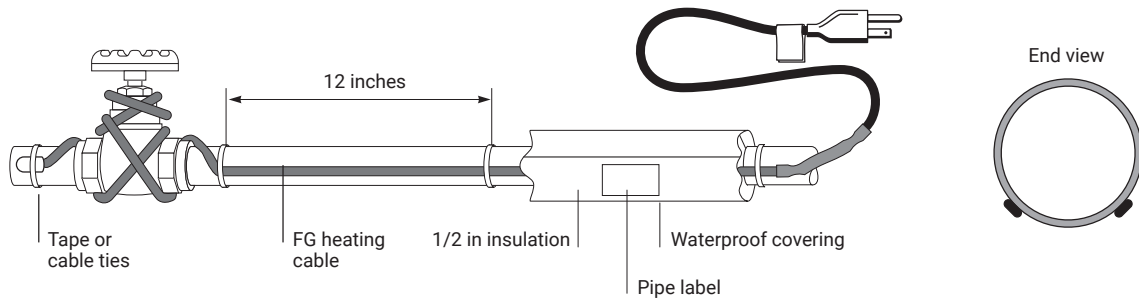

Figure 1. Straight-traced installation

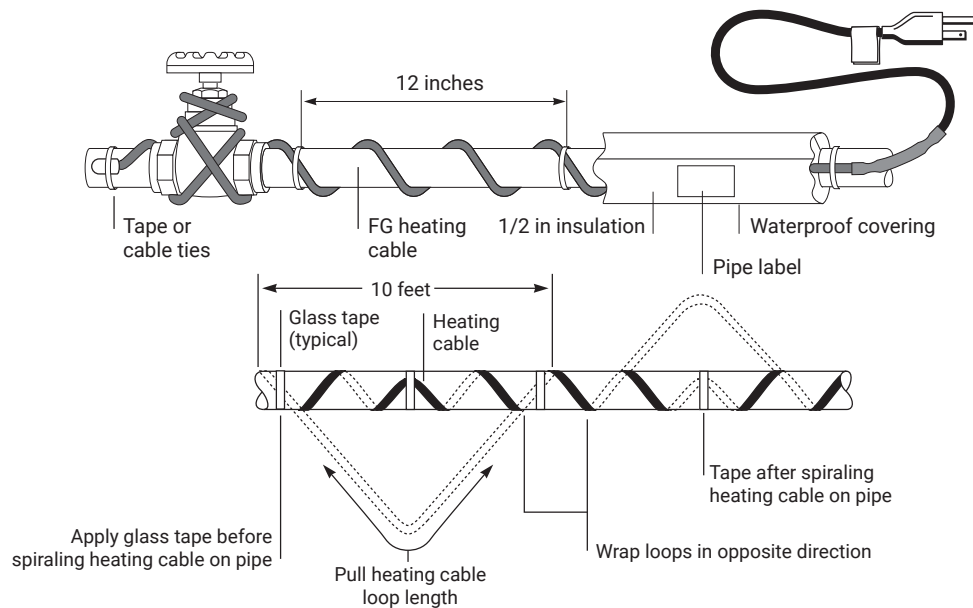

Figure 2. Spiral-traced installation

Heating cable installation

1. Prepare for installation.
 - Store the heating cable in a clean, dry place.
 - Complete piping pressure test.
 - Prior to installing the cable, remove any sharp surfaces on the pipe that might damage the heating cable.
 - Review the FrostGuard heating cable design and compare to materials received to verify that you have the proper FrostGuard heating cable.
 - Walk the system and plan the routing of the FrostGuard heating cable on the pipe.
2. Position and attach heating cable to pipe.
 - Be sure all piping to be traced is dry.
 - Install heating cable, using straight tracing Figure 1, or spiraling Figure 2.
 - For straight tracing, install the heating cable on a lower half of the pipe; for example, in the 4 o'clock or 8 o'clock position.
 - Be sure to install the additional heating cable required for valves, flanges, etc. as shown in Figures 1 and 2.
- When the design calls for spiraling, begin by suspending a loop every 10 feet as shown in Figure 2. To determine the loop length, divide the FrostGuard length by your pipe length and multiply by 10. For example, if you are using a 50 ft FrostGuard on a 40 foot pipe, leave a 12-foot loop of heating cable at every 10-foot section of pipe. Grasp the loop in its center and wrap it around the pipe. Even out the distance between spirals by sliding the wraps along the pipe. Use glass tape to secure the center of the loop to the pipe.
- Fasten FrostGuard heating cable to the pipe at 1-foot intervals using H903 fiberglass application tape or nylon cable ties. Do not use vinyl electrical tape, duct tape, metal bands, or wire.
- If excess cable remains at the end of the pipe, double it back along the pipe.
3. Check the installation.
 - Prior to installing thermal insulation, make sure the heating cable is free of mechanical damage (from cuts, clamps, etc.) and thermal damage (from solder, overheating, etc.).

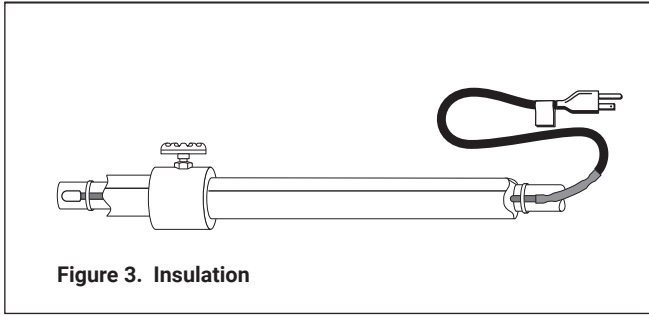

Figure 3. Insulation

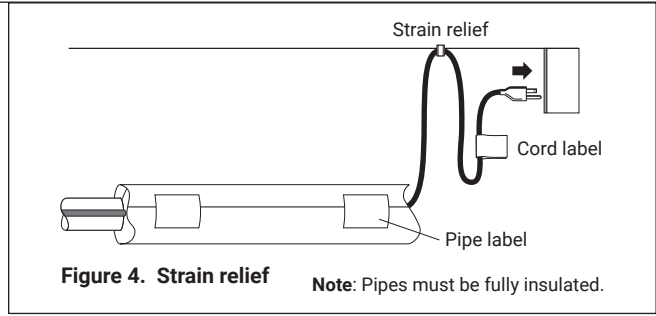

Figure 4. Strain relief

Note: Pipes must be fully insulated.

4. Install thermal insulation.

- A reliable FrostGuard system depends on properly installed and dry, weatherproofed thermal insulation.
- Ensure that at least 1/2" of preformed foam or equivalent thermal insulation is used and that all piping, including valves, joints, and wall penetrations, has been fully insulated as shown in Figure 3.
- For protection to -20°F (-29°C), use 1" thick insulation.
- Install the insulation on the piping as soon as possible to minimize the potential for mechanical damage after installation.
- Be sure the FrostGuard 120 V label is visible on the outside of the thermal insulation.

5. Finishing the installation.

- To prevent damage to the heating cable or cord, secure the power cord (cold lead) with a plastic cable tie, glass cloth tape, or duct tape as shown in Figure 4.
- Two labels indicating the presence of electric pipe heating cable are included with the heating cable. Attach the two "Electric Traced" labels on the outer surface of the pipe insulation at suitable intervals to indicate the presence of FrostGuard electric heating cable.

6. Starting the system.

- nVent recommends that the system be tested per the "Cable testing and maintenance" section below.
- Plug the heating cable into a 120-V ground-fault protected outlet.
- Check the circuit breaker to verify power to the cable.
- Standing water in the pipe should feel warm within an hour.

Cable testing and maintenance

Using a 2500-Vdc megohmmeter, check the insulation resistance between both of the rectangular (power) prongs on the plug and the round (ground) prong after installing the heating cable. Minimum reading should be 1000 megohms.

Record the original values for each circuit, and compare subsequent readings taken during regular maintenance schedules to the original values.

If the readings fall below 1000 megohms, replace the FrostGuard cable with a new unit. Do not attempt to repair the unit.

⚠ WARNING: Fire and Shock Hazard.
 Damaged heating cable can cause electrical shock, arcing, and fire. Do not attempt to repair or energize damaged heating cable. Remove it at once and replace with a new length.

Roof & Gutter De-icing

Note: Route and secure the heating cable to avoid possible mechanical damage, such as from ladders, etc.

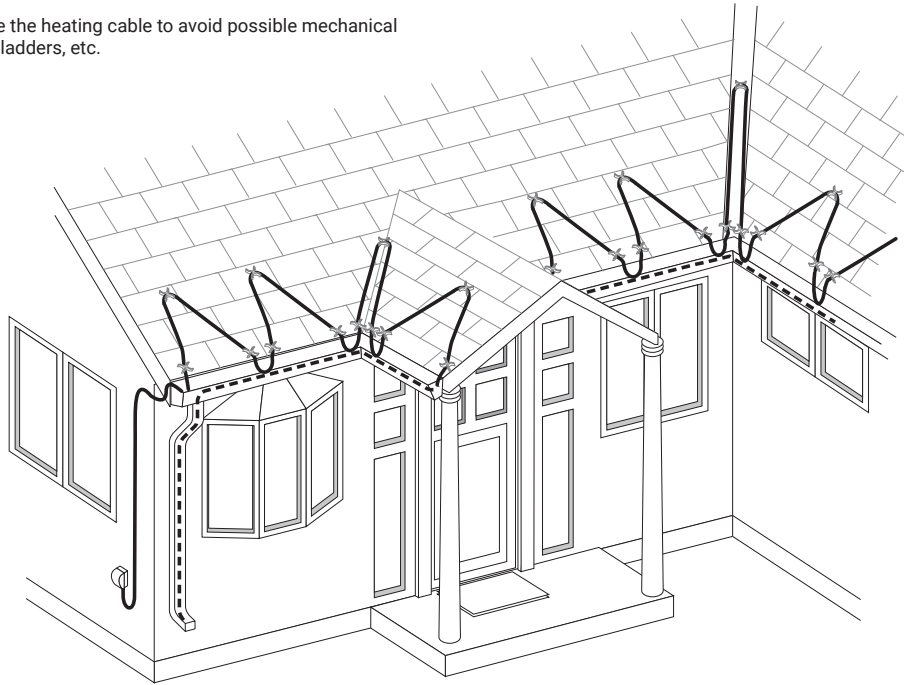

General requirements for roof & gutter de-icing:

- FrostGuard is designed to remove melt water, not accumulated snow.
- FrostGuard heating cable will not keep snow or ice from falling off the roof. Snow fences or snow guards should be used to eliminate snow movement. For the names of manufacturers of snow guards or snow fences, contact nVent at (800) 545-6258.
- FrostGuard heating cables may be used on:
 - Roofs made from all types of standard roofing materials, including shake, shingle, rubber, tar, wood, metal, and plastic.
 - Gutters made from standard materials, including metal and plastic.
 - Downspouts made from standard materials, including metal and plastic.
- Do not use an extension cord.
- Do not install the heating cable underneath any roof covering for roof and gutter de-icing.
- Install only in accessible locations; do not install behind walls or where the cable would be hidden.
- Do not run the heating cable through walls, ceilings, or floors.
- Connect only to ground-fault protected outlets that have been installed in accordance with all prevailing national and local codes and standards and are protected from rain and other water.

Electrical codes

Article 426 of the National Electrical Code (NEC), and Part 1, Section 62 of the Canadian Electrical Code (CEC), govern the installation of FrostGuard heating cables for roof and gutter de-icing and must be followed.

Important: For the nVent warranty to be valid, you must comply with all the requirements outlined in these guidelines.

All design information provided here is based on a “standard” shake or shingle roof application. For any other application or method of installation, consult nVent at (800) 545-6258.

FrostGuard 120 V (FG1) heating cable selection for roof & gutter de-icing

1. Calculate the heating cable length.

Find the number of feet of heating cable needed per foot of roof edge in Table 3. Then, calculate the amount of total heating cable length you need using the following formula:

$$\text{Length} = A + B + C + D$$

A Roof edge length (ft) x Length of cable per foot of roof edge (ft)

B Roof extension: Roof edge (ft) x 0.5*

C Roof gutter: Total gutter length (ft)

D Downspout: Total downspout length (ft) +1 (ft) [double if looping]

= Total heating cable length (ft)

* Roof extension: This length allows the heating cable to extend into the gutter to provide a continuous drain path, or where no gutters are present, extends beyond the roof edge to form a drip loop.

Example: (shingle roof)

Eave overhang: 1 ft / 12 in

Roof edge: 15 ft

Roof gutter: 15 ft

Downspout: 15 ft

FrostGuard heating cable required:

A Roof edge: 15 ft x 2.8 = 42.0 ft

B Roof extension: 15 ft x 0.5 = 7.5 ft

C Roof gutter: 15 ft = 15.0 ft

D Downspout: 15 ft + 1 ft = 16.0 ft

Total heating required: = 80.5 ft

FrostGuard required: FG1-100P

Table 3. Typical spacing and layout measurements

Length of heating cable per foot of roof edge (feet)

Eave overhang (in)	Standing seam metal roof		
	Shingle roof	18 in seam	24 in seam
None	2	2.5	2
12	2.8	2.8	2.4
24	3.8	3.6	2.9
36	4.8	4.3	3.6

Note: nVent recommends the use of gutters and downspouts to provide a continuous path for melted water.

- If downspout is in the middle of the run, loop the FrostGuard down and back up. Double the length of the downspout for determining the length of FrostGuard to install.
- For valleys, run the heating cable two thirds of the way up and down the valley.
- For gutters 5-6 inches wide use 2 runs of heating cable.
- For gutters wider than 6 inches contact nVent, (800) 545-6258

Heating cable installation

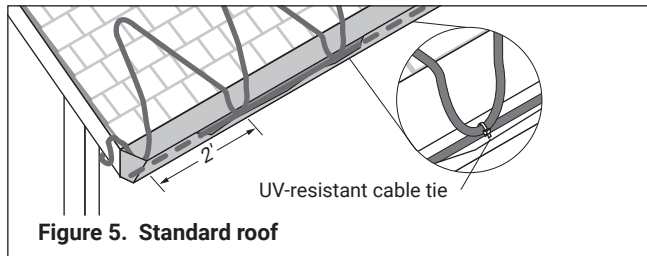

Figure 5. Standard roof

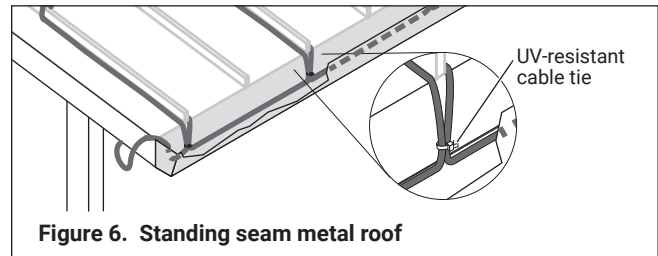

Figure 6. Standing seam metal roof

1. Prepare for installation.

- Store the heating cable in a clean, dry place.
- Use only the following nVent accessories to satisfy code and agency requirements:
 - nVent RAYCHEM H915 Hanger Bracket
 - nVent RAYCHEM H913/H914 Roof Clips
- Make certain gutters and downspouts are free of leaves and other debris.
- Carefully plan the routing of the heating cable for roof and gutter de-icing.

2. Position and attach the heating cable on roofs.

- Loop the heating cable on the overhang area of the roof. This is the part that extends past the building wall. Extend the bottom of each heating cable loop over the roof edge and, using a UV-resistant cable tie, connect the bottom of each loop to the cable running in the gutter to ensure a drainage channel off the roof and into the gutter and downspout. The cable running in the gutter should remain against the bottom of the gutter as shown in Figures 5 and 6.

Table 4. Tracing heights for different roof styles

Shake and Shingle Roof

Roof of overhang (in)	Tracing width (in)	Tracing heights (in)	Feet of FrostGuard per foot roof edge
None*	2	18	2
12	2	18	2.8
24	2	30	3.8
36	2	42	4.8

Standing Seam Metal Roof**

Eave overhang (in)	Standing Seam Spacing (in)	Tracing heights (in)	Feet of FrostGuard per foot of roof edge
None*	18	18	2.5
12	18	24	2.8
24	18	36	3.6
36	18	48	4.3
None*	24	18	2.0
12	24	24	2.4
24	24	36	2.9
36	24	48	3.6

* Gutter required

** No additional heating cable is required for gutters when tracing standing seam metal roofs

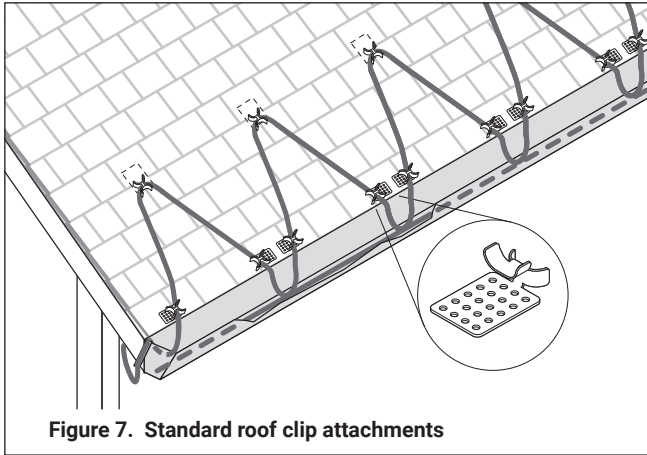

Figure 7. Standard roof clip attachments

- Extend the top of each heating cable loop beyond where the wall joins the roof.
- Trace two-thirds of the way up each valley with a double run of heating cable as shown in Figure 8.
- Use H913/H914 roof clips to route heating cable into and out of the gutter in such a way as to prevent abrasion to the cable. Protect all cable that protrudes past the lower opening of the downspout.
- One H913 kit contains ten roof clips for approximately 7 linear feet of roof edge. One H914 kit contains 50 roof clips for approximately 35 linear feet of roof edge.

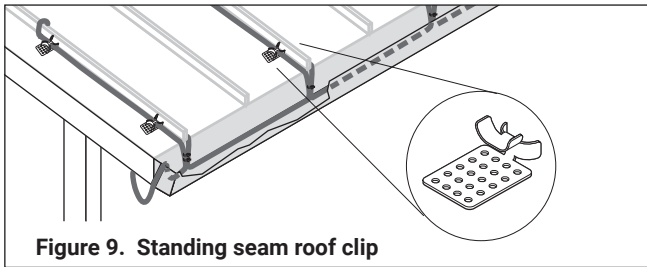

Figure 9. Standing seam roof clip

- Roof clips may be attached to a shake or shingle roof with nails or screws as shown in Figure 7. Roof clips may be attached to a metal roof using screw, nail or adhesive as shown in Figure 9. (See H56723 installation instruction for more details.) Reseal the nail or screw holes if necessary before installing heating cable in the clips.
- A barrier (snow fence) can be placed on the roof above the heating cable. This prevents damage to the cable and keeps the installation from coming loose due to ice slides. The heating cable can be attached to the barrier with UV-resistant cable ties, instead of using roof clips, if desired. Do not use wire or other materials because they may damage the heating cable.

In gutters and downspouts

- Run heating cable along gutters and into downspouts, ending below the freezing level. Permanent attachment of the cable to the gutter bottom is not necessary. Loop the heating cable in downspouts. Do not leave the end of the FrostGuard in air at the end of the downspout as shown in Figure 10.
- Use H915 Hanger Brackets at the gutter/downspout transition to protect the heating cable from fraying and from damage from sharp edges and to provide strain relief as shown in Figure 11. Refer to the H915 kit instructions for installation details.
- Route and secure cable to avoid possible mechanical damage, such as from ladders, etc.

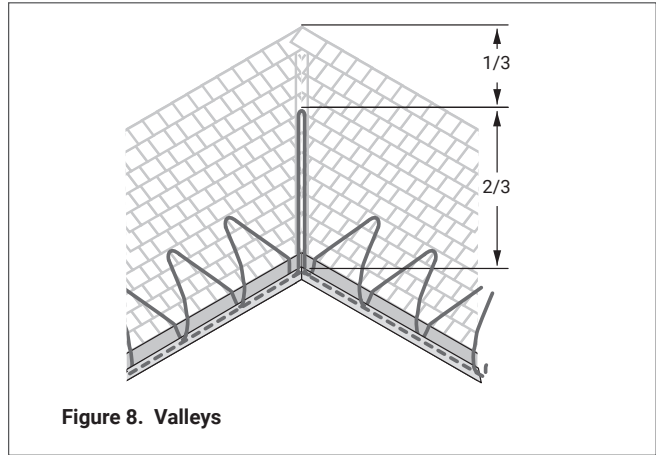

Figure 8. Valleys

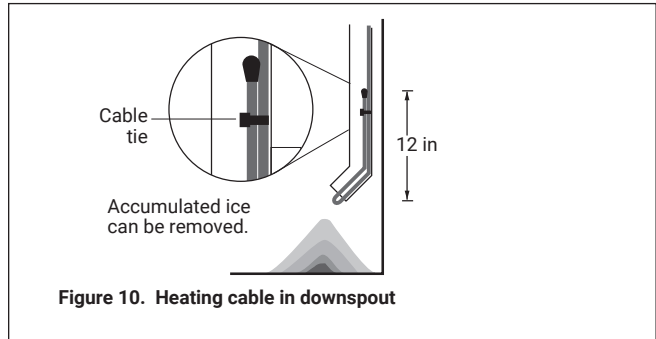

Figure 10. Heating cable in downspout

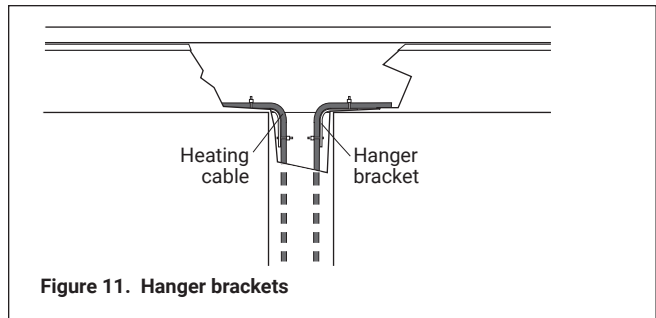

Figure 11. Hanger brackets

3. Mark the installation. Two labels indicating the presence of electric de-icing and snow-melting equipment on the premises are included with the heating cable. One label must be posted at the electrical outlet cover. The other label must be posted at the fuse or circuit breaker panel. The labels must be clearly visible.
4. Check the installation.
 - Prior to plugging in, check to be sure the heating cable is free of mechanical damage (cuts, clamps, etc.).
 - Using a megohmmeter, test each circuit according to the instructions in the "Heating cable testing and maintenance" section on next page.
5. Starting the system.
 - nVent recommends that the system be tested per the "Cable testing and maintenance" section below.
 - Plug the heating cable into a 120-V ground-fault protected outlet.
 - Check the circuit breaker to verify power to the cable.

Heating cable testing and maintenance

Make sure that gutter and downspouts are free of leaves and other debris prior to the winter season.

Using a 2500-Vdc megohmmeter (2500 Vdc minimum), unplug the FrostGuard and test the unit by checking the insulation resistance between the flat blade and the ground pin in the plug. Minimum reading should be 1000 megohms regardless of FrostGuard length.

Record the original values for each circuit. Take additional readings during regularly scheduled maintenance and compare to the original value. If the readings fall below 1000 megohms, inspect heating cables and insulation for signs of damage.



WARNING: Fire and Shock Hazard.

Damaged heating cable can cause electrical shock, arcing, and fire. Do not attempt to repair or energize damaged heating cable. Remove it at once and replace with a new length.

Product specifications

	FG1-6P	FG1-12P	FG1-18P	FG1-24P	FG1-36P	FG1-50P	FG1-75P	FG1-100P
Cable length (ft/m)	6 (1.8)	12 (3.7)	18 (5.5)	24 (7.3)	36 (11)	50 (15)	75 (23)	100 (30)
Min. power output at 40°F (4°C) on pipe (watts)	36	72	108	144	216	300	450	600
Nominal power output in ice and snow (watts)	48	96	144	192	288	400	600	800

General specifications for all FG1 products

Maximum cable width (inch/mm)	0.45 (11.4)
Maximum cable thickness (inch/mm)	0.24 (6.1)
Heating cable bus wire gauge (AWG)	16
Voltage rating (Vac)	110–120
Plug rating (amps)	15
Circuit breaker sizing minimum (amps)	15 A max.
Cold lead length (ft/m)	6 (1.83)
Maximum exposure temperature	150°F (65°C)
Minimum installation temperature	5°F (–15°C)
Minimum bend radius (inch/mm)	5/8 (16)
Electrical classification	Nonhazardous areas only
Exposure to chemicals	None

NORTH AMERICA

Tel +1.800.545.6258
Fax +1.800.527.5703
thermal.info@nvent.com



nVent.com