



# LAMB ELECTRIC



## Product Bulletin

Model: **116757-00**  
**116757-13\***  
**116757-29\*\***

- Two stage
- 120 volts
- 5.7"/145 mm diameter
- Double ball bearings
- Single speed
- ACUSTEK® low-noise peripheral bypass discharge
- Thermostet fan end bracket
- Aluminum commutator bracket

### DESIGN APPLICATION

- Equipment operating in environments requiring separation of working air from motor ventilating air
- Designed to handle clean, dry, filtered air only

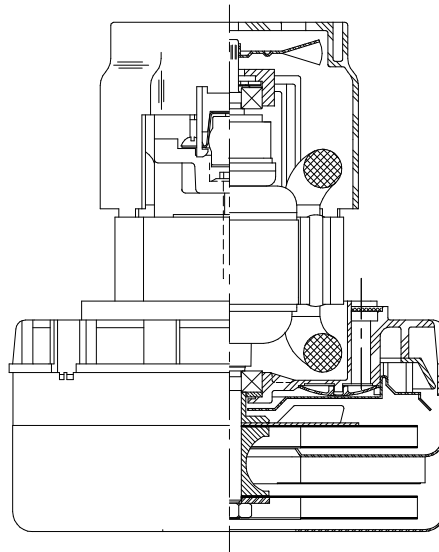

### SPECIAL FEATURES

- Suitable for 120 volt AC operation, 50/60 Hz
- UL recognized, category PRGY2 (E471885)
- CSA certified, class 1611 01 (LR31393)
- Provision for grounding
- Skeleton-frame design
- ACUSTEK® low-noise design, U.S. Patent #1,417,2000
- The Lamb Electric vacuum motor line offers a wide range of performance levels to meet design needs
- \*Model 116757-13 features patented air seal bearing construction, U.S. Patent #4,088,424 and epoxy painted fan case**
- \*\*Model 116757-29 features a 1.5" inlet tube. Drawing not included.**

### TYPICAL MOTOR PERFORMANCE.\*

(At 120 volts, 60Hz, test data is corrected to standard conditions of 29.92 Hg, 68° F.)

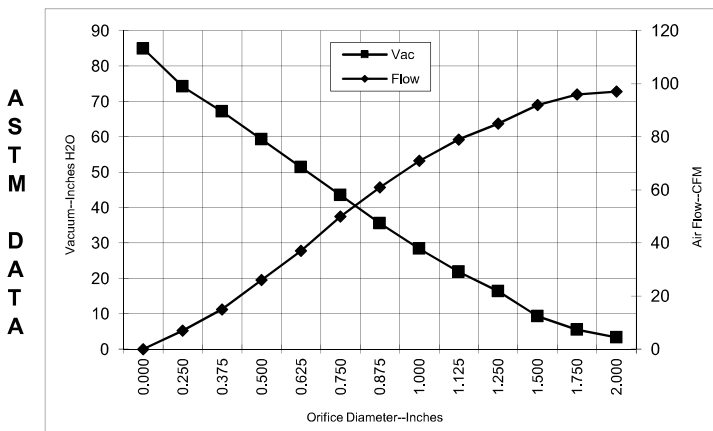

Orifice (Inches)	Amps	Watts (In)	RPM	Vac (In.H2O)	Flow (CFM)	Air Watts
2.000	7.8	901	17649	3.3	97.0	37
1.750	7.8	905	17573	5.5	96.0	62
1.500	7.9	911	17484	9.3	92.0	100
1.250	7.9	918	17431	16.4	85.0	163
1.125	7.9	917	17389	21.9	79.0	204
1.000	7.9	912	17487	28.4	71.0	237
0.875	7.7	895	17692	35.6	61.0	255
0.750	7.4	862	18054	43.5	50.0	253
0.625	7.0	817	18693	51.4	37.0	225
0.500	6.5	758	19523	59.3	26.0	179
0.375	5.9	694	20516	67.2	15.0	122
0.250	5.4	643	21496	74.2	7.0	63
0.000	5.0	596	22332	84.9	0.0	0

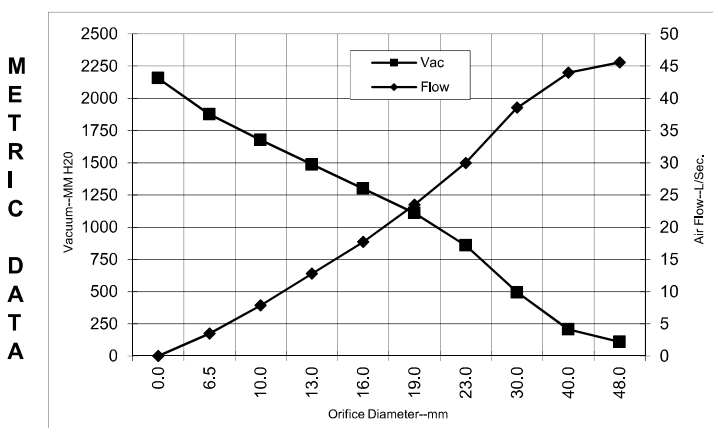

Orifice (mm)	Amps	Watts (In)	RPM	Vac (mm H2O)	Flow (L/Sec)	Air Watts
48.0	7.8	903	17616	108	45.6	48
40.0	7.9	909	17511	207	44.0	89
30.0	7.9	917	17408	493	38.6	186
23.0	7.8	899	17641	859	30.0	251
19.0	7.4	861	18067	1109	23.5	252
16.0	7.0	819	18667	1298	17.7	226
13.0	6.6	764	19440	1486	12.8	184
10.0	6.0	704	20367	1677	7.9	131
6.5	5.4	646	21447	1876	3.5	66
0.0	5.0	596	22332	2156	0.0	0

Note: Metric performance data is calculated from the ASTM data above.

\* Data represents performance of a typical motor sampled from a large production quantity. Individual motor data may vary due to normal manufacturing variations.

Test Specs:	120 volts	Minimum Sealed Vacuum:	80.0"	ORIFICE:	7/8 "	Minimum Vacuum:	33.0"	Maximum Watts:	1050
-------------	-----------	------------------------	-------	----------	-------	-----------------	-------	----------------	------

**DIMENSIONS**

NOTES:

1. LEADS: 18GA STRANDED, LEADS CAN BE ANY COLOR EXCEPT GREEN OR GREEN WITH YELLOW STRIPE.
2. GROUNDING OR EARTHING PROVISIONS: USE HOLES AS INDICATED FOR GROUNDING OR EARTHING. REFER TO APPROPRIATE LISTING OR REGULATORY AGENCY FOR PROPER METHOD OF GROUNDING OR EARTHING.
3. RECOMMENDED SCREW SIZE 10-16 TYPE BT OR 25 THREAD CUTTING SCREW. MAXIMUM PENETRATION 17.40/.685.

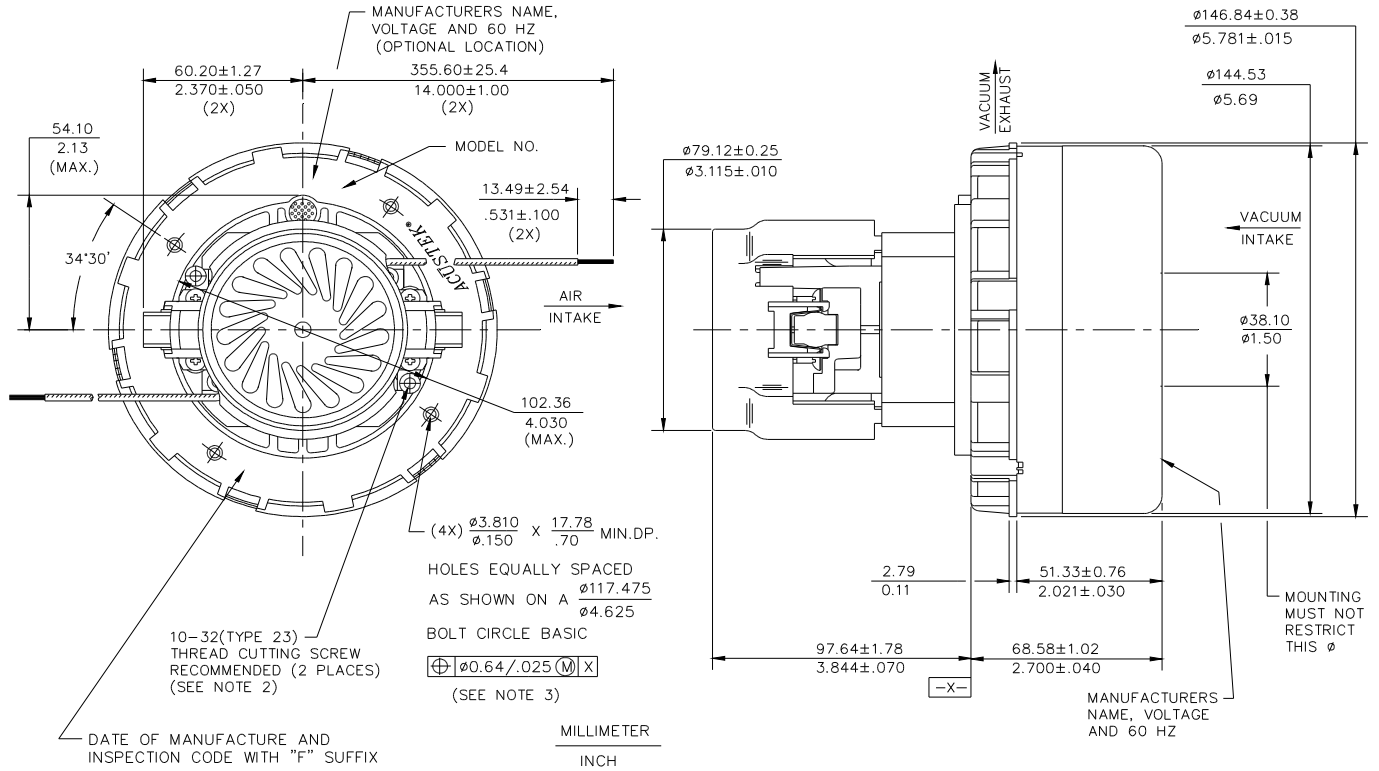

**IMPORTANT NOTE:** Pictorial and dimensional data are subject to change without notice. Contact factory for current revision levels.

**WARNING** - When using AMETEK Lamb Electric bypass motors in machines that come in contact with foam, liquid (including water), or other foreign substances, the machine must be designed and constructed to prevent those substances from reaching the fan system, motor housing, and electrical components. Lamb Electric vacuum motors other than hazardous duty models should not be applied in machines that come in contact with dry chemicals or other volatile materials. Failure to observe these precautions could cause flashing (depending on volatility) or electrical shock which could result in property damage and severe bodily injury, including death in extreme cases. All applications incorporating Lamb Electric motors should be submitted to appropriate organizations or agencies for testing specifically related to the safety of your equipment.

**AMETEK/Floorcare & Specialty Motors**  
**www.ametekfsm.com**