

Speed Controller Adjustable by Flat Head Screwdriver with One-touch Fitting Elbow Type/Universal Type

AS□□□1F-D Series

RoHS

Flow adjustable by flat head screwdriver

Prevention of an unnecessary manual operation

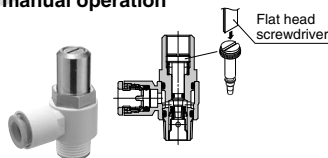

Elbow type



Universal type



Symbol

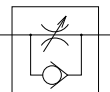

Flow Direction Symbols on Body

	Meter-out type	Meter-in type
Indication symbol		
Symbol		

Model

Elbow type	Universal type	Port size	Applicable tubing O.D.																			
			Metric size						Inch size													
			3.2	4	6	8	10	12	1/8"	3/16"	1/4"	5/16"	3/8"	1/2"								
AS12□1F-M5	AS13□1F-M5	M5 x 0.8	●	●	●																	
AS22□1F-01	AS23□1F-01	R 1/8	●	●	●	●	●															
AS22□1F-02	AS23□1F-02	R 1/4		●	●	●	●															
AS32□1F-02	AS33□1F-02	R 1/4			●	●	●	●														
AS32□1F-03	AS33□1F-03	R 3/8				●	●	●	●													
AS42□1F-04	AS43□1F-04	R 1/2						●	●													
AS12□1F-U10/32	AS13□1F-U10/32	10-32 UNF										●	●	●	●							
AS22□1F-N01	AS23□1F-N01	NPT 1/8										●	●	●	●							
AS22□1F-N02	AS23□1F-N02	NPT 1/4											●	●	●	●						
AS32□1F-N02	AS33□1F-N02	NPT 1/4												●	●	●	●					
AS32□1F-N03	AS33□1F-N03	NPT 3/8													●	●	●					
AS42□1F-N04	AS43□1F-N04	NPT 1/2															●	●				

Note 1) * Elbow type only

Note 2) Meter-out and meter-in types can be visually differentiated by the flow direction symbol on the resin body.

Specifications

Fluid	Air
Proof pressure	1.5 MPa
Max. operating pressure	1 MPa
Min. operating pressure	0.1 MPa
Ambient and fluid temperature	-5 to 60°C (No freezing)
Applicable tubing material ⁽¹⁾	Nylon, Soft nylon, Polyurethane

Note 1) Use caution regarding the max. operating pressure when soft nylon or polyurethane tubing is used. (Refer to pages 464 and 465 for details.)

Note 2) Brass parts are all electroless nickel plated, provided as standard.

Flow Rate and Sonic Conductance

Model	AS12□1F	AS13□1F	AS22□1F-□01	AS23□1F-□01	AS22□1F-□02	AS23□1F-□02	AS32□1F	AS33□1F	AS42□1F	AS43□1F		
	Tubing O.D.	Metric size	ø3.2, ø4, ø6	ø3.2, ø4	ø6, ø8, ø10	ø4	ø6	ø8, ø10	ø6	ø8	ø10, ø12	ø10
	Inch size	ø1/8", ø5/32", ø3/16", ø1/4"	ø1/8", ø5/32"	ø3/16", ø1/4", ø5/16"	ø4/32", ø3/16"	ø1/4", ø5/16", ø3/8"	ø1/4", ø5/16"	ø3/8"	ø3/8"	ø1/2"	ø3/8"	ø1/2"
Controlled flow	Flow rate (L/min (ANR))	100	180	230	260	390	460	660	790	920	1580	1710
	Sonic Conductance (dm ³ /(s.bar))	0.3	0.54	0.7	0.8	1.2	1.4	2	2.4	2.8	4.8	5.2
Critical pressure ratio	Controlled flow	0.2	0.25		0.3		0.25		0.25		0.25	
	Free flow	0.4	0.2		0.3		0.2		0.2		0.3	

Note) Flow rate values are measured at 0.5 MPa and 20°C.



Made to Order

(Refer to page 735 for details.)

How to Order

AS 2 2 1 1 F - 01 - 06 S D -

Body size

1	M5 standard
2	1/8, 1/4 standard
3	3/8 standard
4	1/2 standard

Type

2	Elbow
3	Universal

Control

0	Meter-out
1	Meter-in

Port size

M5	M5 x 0.8
01	R 1/8
02	R 1/4
03	R 3/8
04	R 1/2
U10/32	10-32 UNF
N01	NPT 1/8
N02	NPT 1/4
N03	NPT 3/8
N04	NPT 1/2

Applicable tubing O.D. (Note)

Metric size	Inch size
23	ø3.2*
04	ø4
06	ø6
08	ø8
10	ø10
12	ø12

Inch size	Metric size
01	ø1/8"
03	ø5/32"
07	ø3/16"
09	ø1/4"
11	ø5/16"
13	ø3/8"
11	ø1/2"

Type adjustable by flat head screwdriver
With seal
 Note) In the case that port size is either M5 or 10-32 UNF thread, it is not available with seal. Gasket is provided as standard.

Made to Order
 Refer to the below for details.

Note) For applicable tubing O.D. selection, refer to the Model on page 734.
 * Use ø1/8" tube.

Made to Order



Lubricant: Vaseline

X12

Ex.) AS1201F-M5-23D-X12

Grease-free (Seal: Fluorine Coated) + Throttle Valve (Without Check Valve)

X21

Ex.) AS1201F-M5-23D-X21

Note 1) Not particle-free
 Note 2) Throttle valve is only compatible with the part no. of the meter-out type.

Throttle Valve (Without Check Valve)

X214

Ex.) AS1201F-M5-23D-X214

Note) Throttle valve is only compatible with the part no. of the meter-out type.

Needle Valve/Flow Rate Characteristics

Note) The flow rate characteristics are representative values.

AS1201F, AS1211F

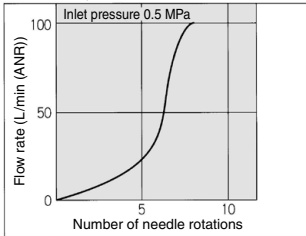

AS2201F-01, AS2211F-01

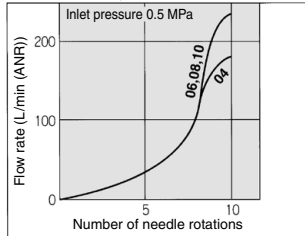

AS2201F-02, AS2211F-02

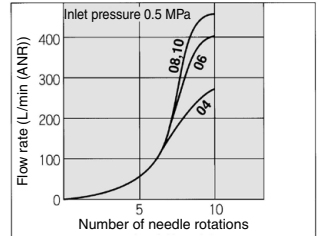

AS3201F, AS3211F

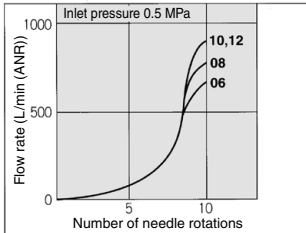

AS4201F, AS4211F

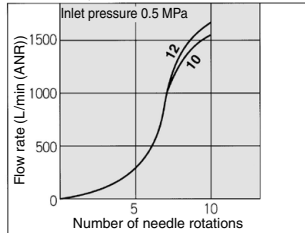

- AS-F
- TMH
- ASD
- AS
- AS-FE
- KE
- AS-FG
- AS-FP
- AS-FM
- AS-D
- AS-T
- ASP
- ASN
- AQ
- ASV
- AK
- VCHC
- ASR
- ASQ

AS□□□1F-D Series

Construction

Elbow type

Meter-out type

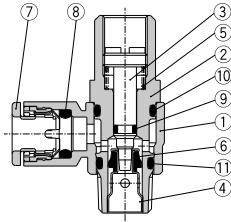

M5 type

U10/32 type

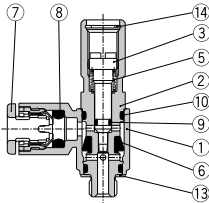

Meter-in type

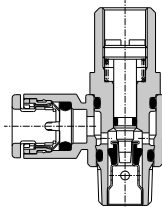

M5 type

U10/32 type

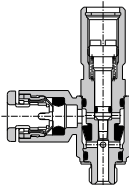

Universal type

Meter-out type

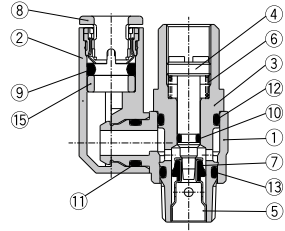

M5 type

U10/32 type

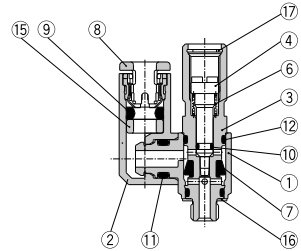

Meter-in type

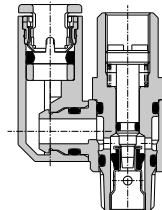

M5 type

U10/32 type

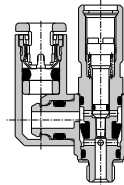

Construction

Elbow type

Meter-out AS3201F-02

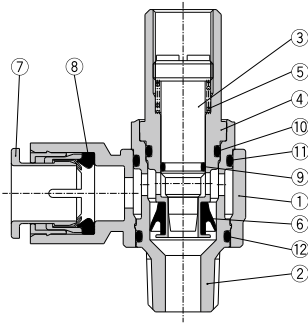

Meter-in AS3211F-02

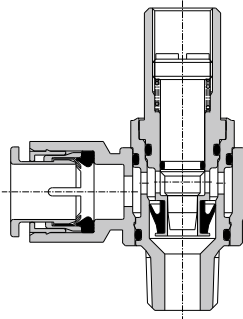

Universal type

Meter-out AS3301F-02

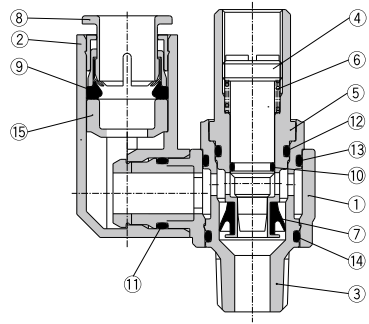

Meter-in AS3311F-02

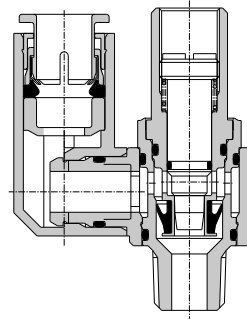

Component Parts

No.	Description	Material	Note
1	Body A	PBT	
2	Body B	Brass	Electroless nickel plated
3	Needle	Brass	Electroless nickel plated
4	Seat ring	Brass	Electroless nickel plated
5	Spring	Steel wire ⁽¹⁾	
6	U seal	HNBR	
7	Cassette	—	
8	Seal	NBR	
9	O-ring	NBR	
10	O-ring	NBR	
11	O-ring	NBR	
12	O-ring	POM	
13	Gasket	NBR, Stainless steel	
14	Retaining ring for hole type C	Tool steel	

Note 1) M5 and U10/32 type: Stainless steel

Component Parts

No.	Description	Material	Note
1	Body A	PBT	
2	Elbow body	PBT	
3	Body B	Brass	Electroless nickel plated
4	Needle	Brass	Electroless nickel plated
5	Seat ring	Brass	Electroless nickel plated
6	Spring	Steel wire ⁽¹⁾	
7	U seal	HNBR	
8	Cassette	—	
9	Seal	NBR	
10	O-ring	NBR	
11	O-ring	NBR	
12	O-ring	NBR	
13	O-ring	NBR	
14	O-ring	NBR	
15	Spacer	—	
16	Gasket	NBR, Stainless steel	
17	Retaining ring for hole type C	Tool steel	

Note 1) M5 and U10/32 type: Stainless steel

AS-F
 TMH
 ASD
 AS
 AS-FE
 KE
 AS-FG
 AS-FP
 AS-FM
AS-D
 AS-T
 ASP
 ASN
 AQ
 ASV
 AK
 VCHC
 ASR
 ASQ

AS□□□1F-D Series

Dimensions

Elbow type

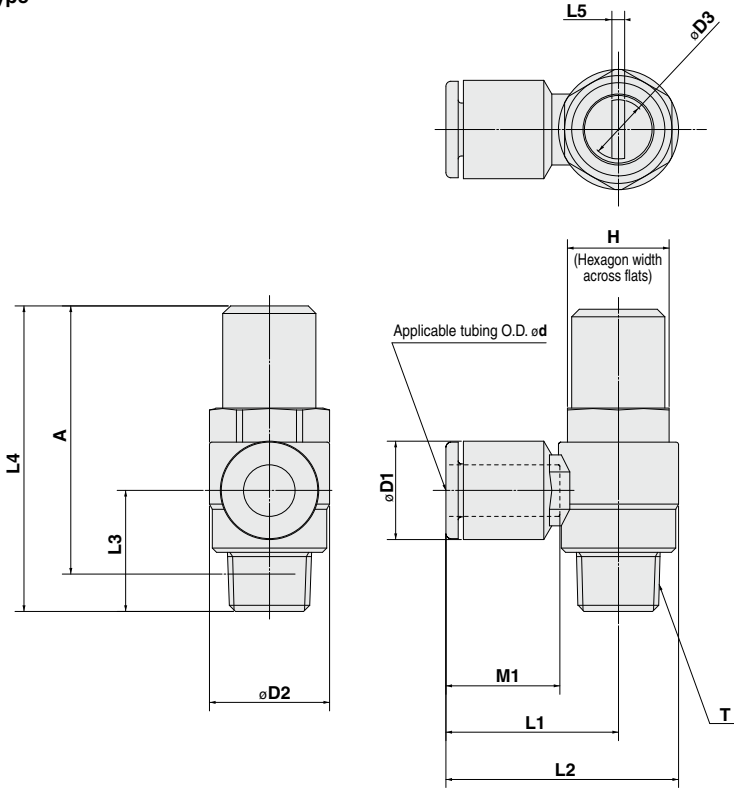

Metric Size

Model	d	T	H	D1	D2	D3	L1	L2	L3	L4	L5	A*	M1	Weight (g)
AS12□1F-M5-23D	3.2			8.4			17.3	22.1	12.3				12.7	10
AS12□1F-M5-04D	4	M5 x 0.8	8	9.3	9.6	4.7	17.3	22.1	12.3	31	0.7	27.4	12.7	10
AS12□1F-M5-06D	6			11.6			18.1	22.9	11.7				13.5	20
AS22□1F-01-23SD	3.2			8.4			20.4	27.5	13.4				12.7	21
AS22□1F-01-04SD	4			9.3			20.4	27.5	13.4				13.5	23
AS22□1F-01-06SD	6	R 1/8	12	11.6	14.2	7.2	25.3	32.4		34.7	1.2	31.6	18.5	25
AS22□1F-01-08SD	8			15.2			35.3	44.5	15.3				21	25
AS22□1F-01-10SD	10			18.5									16	40
AS22□1F-02-04SD	4			10.4			25.2	34.4					17	42
AS22□1F-02-06SD	6	R 1/4	17	12.8	18.5	7.2	35.3	44.5	18.3	40.2	1.2	34.7	18.5	42
AS22□1F-02-08SD	8			15.2			27.2	36.4					21	44
AS22□1F-02-10SD	10			18.5			29.5	41					17	73
AS32□1F-02-06SD	6			12.8			27.8	39.3					18.5	76
AS32□1F-02-08SD	8	R 1/4	19	15.2	23	9.8	31.8	43.3	21.3	54.8	1.2	49.3	21	80
AS32□1F-02-10SD	10			18.5			32.8	44.3					22	82
AS32□1F-02-12SD	12			20.9			32.8	44.3					17	77
AS32□1F-03-06SD	6			12.8			29.5	41					18.5	79
AS32□1F-03-08SD	8	R 3/8	19	15.2	23	9.8	31.8	43.3	19.8	52.6	1.2	47.4	21	81
AS32□1F-03-10SD	10			18.5			32.8	44.3					22	83
AS32□1F-03-12SD	12			20.9			33.6	47.9					21	141
AS42□1F-04-10SD	10	R 1/2	24	18.5	28.6	12.4	35.2	49.5	24.5	62.9	1.2	55.8	22	142
AS42□1F-04-12SD	12			20.9										

* Reference dimensions of M5 x 0.8, R threads after installation.

Inch Size

Model	d	T	H	D1	D2	D3	L1	L2	L3	L4	L5	A*	M1	Weight (g)
AS12□1F-U1032-01D	1/8"			8.4			17.3	22.1	12.3				12.7	10
AS12□1F-U1032-03D	3/32"	10-32 UNF	8	9.3			17.3	22.1	12.3	31	0.7	27.4	12.7	10
AS12□1F-U1032-05D	3/16"			11.4	9.6	4.7	18.1	22.9	11.7				13.5	20
AS12□1F-U1032-07D	1/4"			14.4			20.4	27.5	13.4				12.7	20
AS22□1F-N01-01SD	1/8"			8.4			20.4	27.5					13.5	21
AS22□1F-N01-03SD	3/32"			9.3			20.4	27.5					17	23
AS22□1F-N01-05SD	3/16"	NPT 1/8	12.7	13.2	14.2	7.2	25.3	32.4	13.4	34.7	1.2	31.6	18.5	25
AS22□1F-N01-07SD	1/4"			13.2			23.9	31					17	23
AS22□1F-N01-09SD	5/16"			15.2			25.3	32.4					18.5	25
AS22□1F-N02-03SD	5/32"			10.4			25.2	34.4					16	40
AS22□1F-N02-05SD	3/16"			12.8			25.2	34.5					16.5	40
AS22□1F-N02-07SD	1/4"	NPT 1/4	17.5	13.2	18.5	7.2	25.2	34.5	17.7	40.2	1.2	34.7	17	42
AS22□1F-N02-09SD	5/16"			15.2			27.2	36.4					18.5	44
AS22□1F-N02-11SD	3/8"			18.3			25.3	44.5	18.3				21	41
AS32□1F-N02-07SD	1/4"			13.2			27.8	39.3					17	73
AS32□1F-N02-09SD	5/16"	NPT 1/4	19	15.2	23	9.8	29.5	41	21.3	54.8	1.2	49.3	18.5	76
AS32□1F-N02-11SD	3/8"			17.9			31.8	43.3					21	80
AS32□1F-N03-07SD	1/4"			13.2			27.8	39.3					17	77
AS32□1F-N03-09SD	5/16"	NPT 3/8	19	15.2	23	9.8	29.5	41	19.8	52.6	1.2	47.4	18.5	79
AS32□1F-N03-11SD	3/8"			17.9			31.8	43.3					21	81
AS42□1F-N04-11SD	3/8"			17.9			33.6	47.9					21	141
AS42□1F-N04-13SD	1/2"	NPT 1/2	23.8	21.7	28.6	12.4	35.2	49.5	24.5	62.9	1.2	55.8	22	142

* Reference dimensions of 10-32 UNF and NPT threads after installation.

Dimensions

Universal type

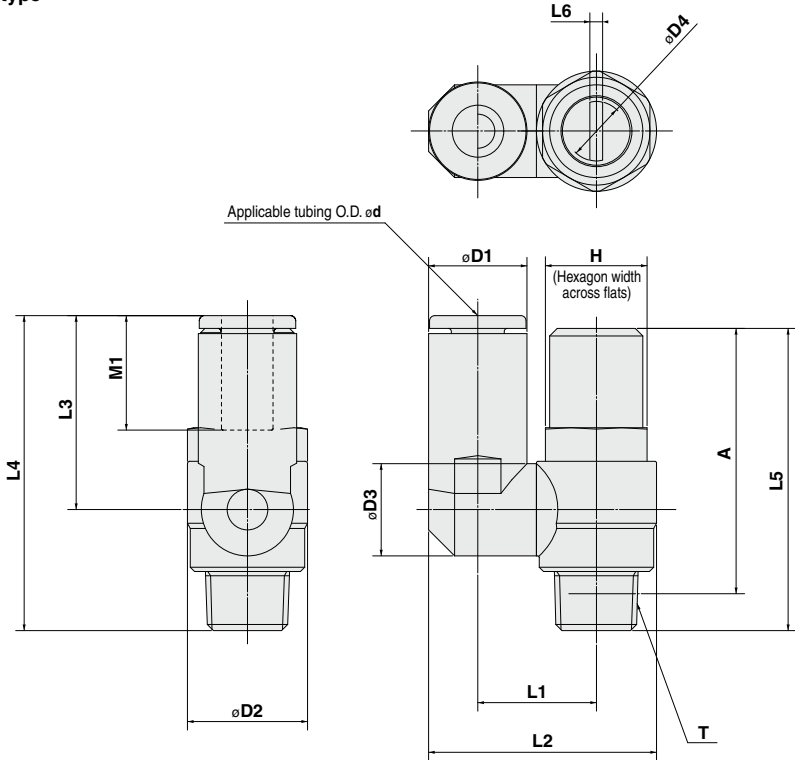

Metric Size

Model	d	T	H	D1	D2	D3	D4	L1	L2	L3	L4	L5	L6	A*	M1	Weight (g)	
AS13□1F-M5-23D	3.2			8.4					19.8	17.5	28.7			0.7	27.4	12.7	10
AS13□1F-M5-04D	4	M5×0.8	8	9.3	9.6	9.3	4.7	10.8	20.3	21.4	20.6	31.8				13.5	
AS13□1F-M5-06D	6			11.6					21.4	20.6	31.8					13.5	
AS23□1F-01-23SD	3.2			8.4		9.3			13.1	24.4	17.5	30.9				12.7	21
AS23□1F-01-04SD	4		R 1/8	9.3		10.9		7.2	14	24.9	22.9	36.3			34.7	1.2	31.6
AS23□1F-01-06SD	6			11.6		12.9			16.2	30.9	28.2	40.8				13.5	22
AS23□1F-01-08SD	8			15.2		12.9			16.2	30.9	28.2	40.8				18.5	25
AS23□1F-02-04SD	4		R 1/4	10.4		10.9			16.2	30.6	21.9	39.6				16	40
AS23□1F-02-06SD	6			12.8		12.9		7.2	18.4	34	25.2	42.1				17	41
AS23□1F-02-08SD	8			15.2		12.9			18.3	35.2	28.2	45.1				16.5	44
AS23□1F-02-10SD	10			18.5		12.9			20.2	38.7	31	47.9				21	48
AS33□1F-02-06SD	6		R 1/4	12.8		12.9			20.6	38.5	25.2	46.5				17	73
AS33□1F-02-08SD	8			15.2		12.9		9.8	20.6	39.7	28.2	49.5				18.5	76
AS33□1F-02-10SD	10			18.5		12.9			20.6	43.7	32.6	52.9	54.8	1.2	49.3	21	80
AS33□1F-02-12SD	12			20.9		16.2			23	44.9	34.4	55.7				22	82
AS33□1F-03-06SD	6		R 3/8	12.8		12.9		9.8	20.6	38.5	25.2	45				17	78
AS33□1F-03-08SD	8			15.2		12.9			20.6	39.7	28.2	48	52.6	1.2	47.4	18.5	81
AS33□1F-03-10SD	10			18.5		12.9			23	43.7	32.6	52.4				21	85
AS33□1F-03-12SD	12			20.9		16.2			23	44.9	34.4	54.2				22	87
AS43□1F-04-10SD	10		R 1/2	18.5		16.2	12.4		25.8	49.4	32.6	57.1				21	145
AS43□1F-04-12SD	12			20.9		19.4			26.8	52	36.3	60.8				22	147

* Reference dimensions of M5 x 0.8, R threads after installation.

Inch Size

Model	d	T	H	D1	D2	D3	D4	L1	L2	L3	L4	L5	L6	A*	M1	Weight (g)	
AS13□1F-U1032-01D	1/8"			8.4					19.8	17.5	28.7					12.7	10
AS13□1F-U1032-03D	3/32"			9.3					20.3	21.3	23.3	34.5	31	0.7	37.4	16.5	11
AS13□1F-U1032-05D	5/32"	10-32 UNF	8	11.4		9.6	9.3	4.7	10.8	11.4	20.6	31.8				13.5	
AS13□1F-U1032-06D	3/16"			12					12	12	20.6	31.8				13.5	
AS23□1F-M01-01SD	1/8"			8.4		9.3			13.1	24.4	17.5	30.9				12.7	21
AS23□1F-M01-03SD	3/32"			9.3		10.9		7.2	14	24.9	22.9	36.3			34.7	1.2	31.6
AS23□1F-M01-03SD	5/32"			11.6		12.9			16.2	30.9	28.2	40.8				18.5	25
AS23□1F-M01-03SD	3/16"	NPT 1/8		11.4		10.9	7.2	14	12.7	11.4	14	26.8	23.9	37.3	34.7	1.2	31.6
AS23□1F-M01-07SD	1/4"			13.2		12.9			16.2	29.9	25.6	38.2				17	23
AS23□1F-M01-09SD	5/16"			15.2		12.9			16.2	30.9	28.2	40.8				18.5	25
AS23□1F-M02-03SD	5/32"			10.4		10.9			16.2	30.6	21.9	39.6				16	40
AS23□1F-M02-05SD	3/16"			11.4		10.9			16.2	31.1	23.9	41.6				16.5	41
AS23□1F-M02-07SD	1/4"	NPT 1/4		13.2		12.9		7.2	18.3	34.2	25.6	42.5	40.2	1.2	34.7	17	44
AS23□1F-M02-09SD	5/16"			15.2		12.9			16.2	35.2	28.2	45.1				18.5	47
AS23□1F-M02-11SD	3/8"			17.9		12.9			20.2	38.7	31	47.9				21	48
AS33□1F-M02-07SD	1/4"			13.2		12.9			16.2	30.6	21.9	46.9				17	73
AS33□1F-M02-09SD	5/16"	NPT 1/4		15.2		12.9	9.8	20.6	20.6	39.7	28.2	49.5	54.8	1.2	49.3	18.5	76
AS33□1F-M02-11SD	3/8"			17.9		16.2			23	43.7	32.6	53.9				21	82
AS33□1F-M03-07SD	1/4"			13.2		12.9		9.8	20.6	38.7	25.6	45.4				17	78
AS33□1F-M03-09SD	5/16"	NPT 3/8		15.2		12.9	9.8	20.6	20.6	39.7	28.2	48	52.6	1.2	47.4	18.5	81
AS33□1F-M04-11SD	3/8"			17.9		16.2			23	43.7	32.6	52.4				21	87
AS43□1F-M04-11SD	3/8"	NPT 1/2	23.8	29	19.4	12.4			25.8	49.4	32.6	57.1				21	145
AS43□1F-M04-13SD	1/2"		23.8	21.7	19.4	12.4			26.8	52	36.3	60.8				22	147

* Reference dimensions of 10-32 UNF and NPT threads after installation.

- AS-F
- TMH
- ASD
- AS
- AS-FE
- KE
- AS-FG
- AS-FP
- AS-FM
- AS-D
- AS-T
- ASP
- ASN
- AQ
- ASV
- AK
- VCHC
- ASR
- ASQ

Speed Controller Adjustable by Flat Head Screwdriver with One-touch Fittings In-line Type

AS□□□1F-D Series



Model

Model	Applicable tubing O.D.												
	Metric size						Inch size						
	3.2	4	6	8	10	12	1/8"	5/32"	3/16"	1/4"	5/16"	3/8"	1/2"
AS1001F	●	●	●				●	●	●	●			
AS2001F		●	●					●	●	●			
AS2051F			●	●					●	●	●		
AS3001F			●	●	●	●			●	●	●	●	
AS4001F					●	●						●	●

Specifications

Fluid	Air
Proof pressure	1.5 MPa
Max. operating pressure	1 MPa
Min. operating pressure	0.1 MPa
Ambient and fluid temperature	-5 to 60°C (No freezing)
Applicable tubing material ⁽¹⁾	Nylon, Soft nylon, Polyurethane

Note 1) Use caution regarding the max. operating pressure when soft nylon or polyurethane tubing is used. (Refer to pages 464 and 465 for details.)

Note 2) Brass parts are all electroless nickel plated.

Flow Rate and Sonic Conductance

Model	AS1001F	AS2001F	AS2051F	AS3001F	AS4001F						
Tubing O.D.	Metric size	ø3.2, ø4, ø6	ø4	ø6	ø6	ø8	ø6	ø8	ø10, ø12	ø10	ø12
	Inch size	ø1/8", ø5/32", ø3/16", ø1/4"	ø5/32"	ø3/16", ø1/4"	ø3/16"	ø1/4", ø5/16"	ø1/4"	ø5/16"	ø3/8"	ø3/8"	ø1/2"
Controlled flow	Flow rate (L/min (ANR))	100	130	230	290	460	420	660	920	1050	1390
	Sonic Conductance dm ³ /(s·bar)	0.3	0.4	0.7	0.9	1.4	1.3	2	2.8	3.2	4.2
Critical pressure ratio	Controlled flow	0.2	0.2	0.2	0.2	0.2	0.2	0.2	0.2	0.2	0.2
	Free flow	0.25	0.25	0.25	0.25	0.25	0.25	0.25	0.25	0.25	0.25

Note) Flow rate values are measured at 0.5 MPa and 20°C

Symbol

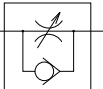

Flow Direction Symbols on Body



Made to Order

Made to Order
(For details, refer to page 743.)

Symbol	Specifications
-X12	Lubricant: Vaseline
-X21	Grease-free (Seal: Fluorine-coated) + Throttle valve (Without check valve)
-X214	Throttle valve (Without check valve)

Caution

Be sure to read this before handling the products. Refer to back page 50 for Safety Instructions and pages 543 to 546 for Flow Control Equipment Precautions.

How to Order

AS 200 1F — 06 D — □

Body size

100	M5 standard
200	1/8 standard
205	1/4 standard
300	3/8 standard
400	1/2 standard

With One-touch fittings

Type adjustable by flat head screwdriver

Applicable tubing O.D. ^{Note)}

Metric size	Inch size
23	ø3.2"
04	ø4
06	ø6
08	ø8
10	ø10
12	ø12
01	ø1/8"
03	ø5/32"
05	ø3/16"
07	ø1/4"
09	ø5/16"
11	ø3/8"
13	ø1/2"

Made to Order
Refer to page 743 for details.

Note) For applicable tubing O.D. selection, refer to the Model.
* Use ø1/8" tube.

Needle Valve/Flow Rate Characteristics

Note) The flow rate characteristics are representative values.

AS1001F

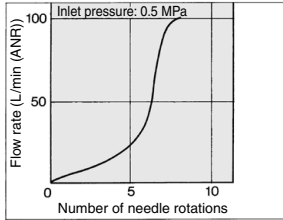

AS2001F

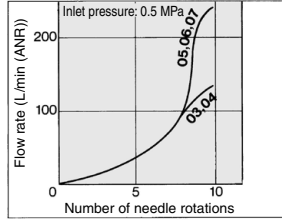

AS2051F

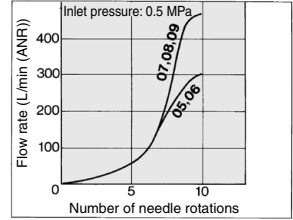

AS3001F

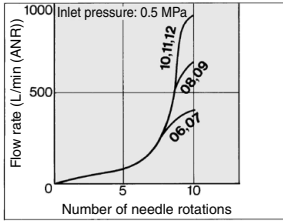

AS4001F

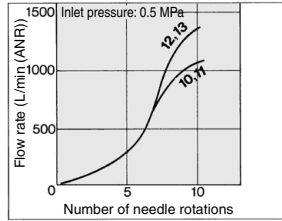

Construction

AS1001F

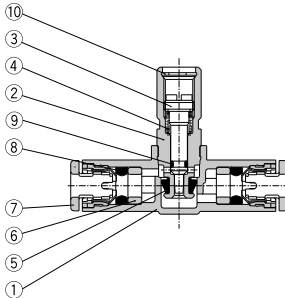

AS2001F to AS4001F

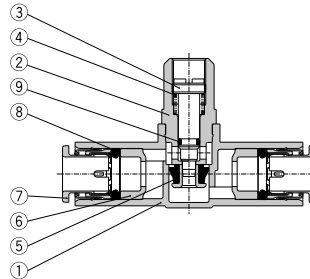

Component Parts

No.	Description	Material	Note
1	Body A	PBT	
2	Body B	Brass	Electroless nickel plated
3	Needle	Brass	Electroless nickel plated
4	Spring	Steel wire ⁽¹⁾	
5	U seal	HNBR	
6	Spacer	—	
7	Cassette	—	
8	Seal	NBR	
9	O-ring	NBR	
10	Retaining ring for hole type C	Tool steel	

Note 1) AS1001F type: Stainless steel

- AS-F
- TMH
- ASD
- AS
- AS-FE
- KE
- AS-FG
- AS-FP
- AS-FM
- AS-D
- AS-T
- ASP
- ASN
- AQ
- ASV
- AK
- VCHC
- ASR
- ASQ

AS□□□1F-D Series

Dimensions

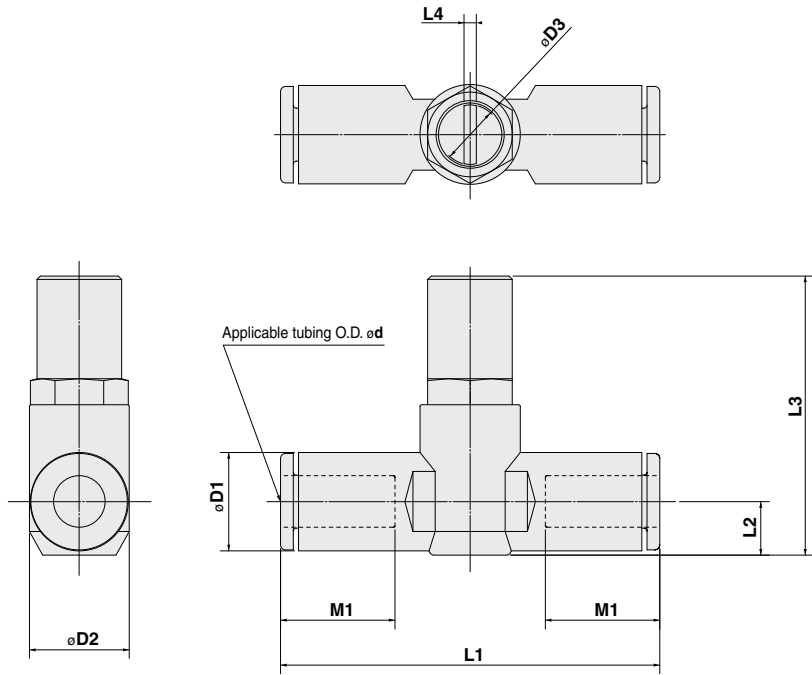

Metric Size

Model	d	D1	D2	D3	L1	L2	L3	L4	M1	Weight (g)
AS1001F-23D	3.2	8.4			38	4.5	26		12.7	8
AS1001F-04D	4	9.3	10.5	4.7	39.2	5.2	26.6	0.7	13.5	9
AS1001F-06D	6	11.6			40.7	6.2	27.7		13.5	10
AS2001F-04D	4	9.3			40.7	5.2	31.9		12.7	15
AS2001F-06D	6	11.6	12.3	7.2	44.8	6.3	33	1.2	13.5	16
AS2051F-06D	6	12.8			53.2	6.7	35.2		17	33
AS2051F-08D	8	15.2	15.5	7.2	59.8	8.1	36.5	1.2	18	36
AS3001F-06D	6	12.8			59	7.4	45		17	56
AS3001F-08D	8	15.2			64.4	8.2	45.8		18	60
AS3001F-10D	10	18.5	20.6	9.8	71.6	9.8	47.3	1.2	21	64
AS3001F-12D	12	20.9			76	11	48.5		22	68
AS4001F-10D	10	18.5			77.7	11.3	55.4	1.2	21	121
AS4001F-12D	12	20.9	27.6	12.4	82.1		56.4		22	125

Inch Size

Model	d	D1	D2	D3	L1	L2	L3	L4	M1	Weight (g)
AS1001F-01D	1/8"	8.4			38	4.5	26		12.7	8
AS1001F-03D	5/32"	9.3			39.2	5.2	26.6	0.7	13.5	9
AS1001F-05D	3/16"	11.4			40.7	6.2	27.7		13.5	14
AS1001F-07D	1/4"	12			40.7	5.2	31.9		12.7	15
AS2001F-03D	5/32"	9.3			44.8	6.3	33	1.2	13.5	16
AS2001F-05D	3/16"	11.4			50	6.2	32.8	1.2	17	33
AS2001F-07D	1/4"	13.2			52.2	7.1	33.7		17	19
AS2051F-05D	3/16"	11.4			52.2	6.2	34.9		16.5	35
AS2051F-07D	1/4"	13.2	15.5	7.2	54.4	7.1	35.7	1.2	17	33
AS2051F-09D	5/16"	15.2			59.8	8.1	36.7		18	36
AS3001F-07D	1/4"	13.2			59	7.4	45.2		17	56
AS3001F-09D	5/16"	15.2	20.6	9.8	64.4	8.2	46	1.2	18	60
AS3001F-11D	3/8"	17.9			70.8	9.5	47.2		21	72
AS4001F-11D	3/8"	17.9	27.6	12.4	76.9	10.3	55.5	1.2	21	129
AS4001F-13D	1/2"	21.7			83.1	11.6	56.9		22	142

AS□□□1F-D Series

Made to Order Specifications

Please contact SMC for detailed dimensions, specifications and lead times.



Lubricant: Vaseline

X12

Ex.) AS1001F-23D-X12

**Grease-free (Seal: Fluorine Coated) +
Throttle Valve (Without Check Valve)**

X21

Ex.) AS1001F-23D-X21

Note 1) Not particle-free

Throttle Valve (Without Check Valve)

X214

Ex.) AS1001F-23D-X214

AS-F

TMH

ASD

AS

AS-FE

KE

AS-FG

AS-FP

AS-FM

AS-D

AS-T

ASP

ASN

AQ

ASV

AK

VCHC

ASR

ASQ

Dual Speed Controller Adjustable by Flat Head Screwdriver with One-touch Fitting

ASD□□□F-D Series

RoHS

Model



Model	Port size	Applicable tubing O.D.																		
		Metric size					Inch size													
		4	6	8	10	12	1/8"	5/32"	3/16"	1/4"	5/16"	3/8"								
ASD230F-M5	M5 x 0.8	●	●																	
ASD330F-01	R 1/8		●	●																
ASD430F-02	R 1/4		●	●	●															
ASD530F-02	R 1/4		●	●	●	●														
ASD530F-03	R 3/8		●	●	●	●														
ASD630F-04	R 1/2				●	●														
ASD230F-U10/32	10-32 UNF									●	●	●	●							
ASD330F-N01	NPT 1/8												●							
ASD430F-N02	NPT 1/4													●	●	●				
ASD530F-N02	NPT 1/4													●	●	●				
ASD530F-N03	NPT 3/8													●	●	●				
ASD630F-N04	NPT 1/2																			●

Specifications

Symbol

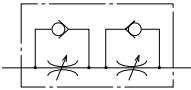

Fluid	Air
Proof pressure	1.5 MPa
Max. operating pressure	1 MPa
Min. operating pressure	0.1 MPa
Ambient and fluid temperature	-5 to 60°C (No freezing)
Applicable tubing material ⁽¹⁾	Nylon, Soft nylon, Polyurethane

Note 1) Use caution regarding the max. operating pressure when soft nylon or polyurethane tubing is used. (Refer to pages 464 and 465 for details.)

Note 2) Brass parts are all electroless nickel plated, provided as standard.

Flow Direction Symbols on Body

	Meter-out type	Meter-in type
Indication symbol		
Symbol		

Flow Rate and Sonic Conduction

Model		ASD230F	ASD330F	ASD430F		ASD530F			ASD630F	
		Metric size	ø4, ø6	ø6, ø8	ø6	ø8, ø10	ø6	ø8	ø10, ø12	ø10
Tubing O.D.	Metric size	ø1/8"	ø3/16"	—	ø1/4"	ø1/4"	ø5/16"	ø3/8"	—	ø3/8"
	Inch size	ø5/32"	ø1/4"	—	ø3/8"					
Controlled flow	Flow rate (L/min (ANR))	75	175	295	350	500	600	700	1200	1300
	Sonic conduction dm ³ /(s·bar)	0.22	0.54	0.9	1.06	1.52	1.82	2.14	3.66	3.96
Critical pressure ratio	Controlled flow	0.25	0.2	0.2		0.2			0.2	
	Free flow	0.3	0.15	0.15		0.15			0.15	

Note) Flow rate values are measured at 0.5 MPa and 20°C.

Made to Order



Lubricant: Vaseline

X12

Ex.) ASD230F-M5-04D-X12

How to Order

ASD **F** - - **S** **D** -

Body size

2	M5 standard
3	1/8 standard
4	1/4 standard
5	3/8 standard
6	1/2 standard

Made to Order
 X12 | Lubricant: Vaseline
 Ex.) ASD230F-M5-04D-X12

Type adjustable by a flat head screwdriver

With seal
 Note) In case that connecting port is either M5 or 10-32UNF thread, it is not available with seal. With gasket is provided as standard.

Universal
With One-touch fitting

Applicable tubing O.D.

Metric size	Inch size
04	ø4
06	ø6
08	ø8
10	ø10
12	ø12
01	ø1/8"
03	ø5/32"
05	ø3/16"
07	ø1/4"
09	ø5/16"
11	ø3/8"

Port size

M5	M5 x 0.8
01	R 1/8
02	R 1/4
03	R 3/8
04	R 1/2
U10/32	10-32 UNF
N01	NPT 1/8
N02	NPT 1/4
N03	NPT 3/8
N04	NPT 1/2

Caution

Be sure to read this before handling the products. Refer to back page 50 for Safety Instructions and pages 543 to 546 for Flow Control Equipment Precautions.

Needle Valve/Flow Rate Characteristics

Note) The flow rate characteristics are representative values.

ASD230F

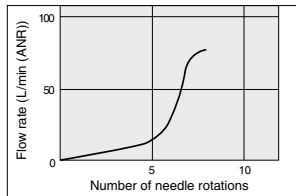

ASD330F

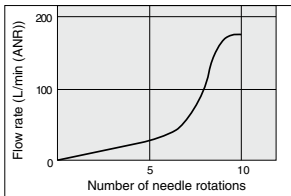

ASD430F

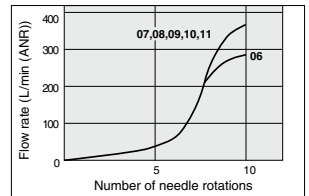

ASD530F

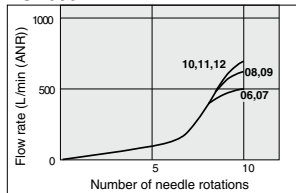

ASD630F

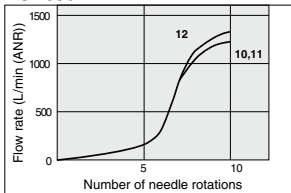

AS-F

TMH

ASD

AS

AS-FE

KE

AS-FG

AS-FP

AS-FM

AS-D

AS-T

ASP

ASN

AQ

ASV

AK

VCHC

ASR

ASQ

ASD□□□F-D Series

Construction

ASD230F

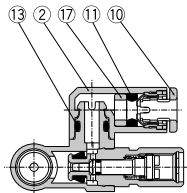

ASD330F/430F
ASD530F/630F

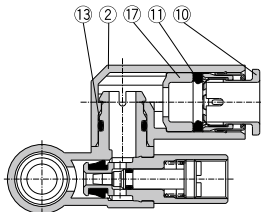

ASD530F-02

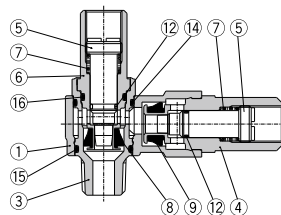
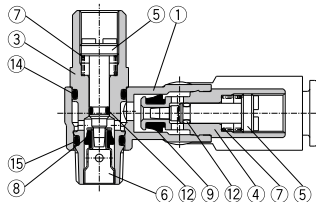
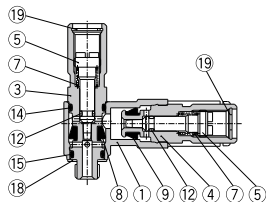
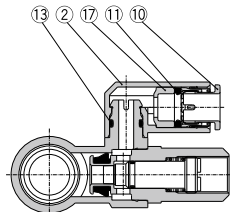

Component Parts

No.	Description	Material	Note
1	Body A	PBT	
2	Elbow body	PBT	
3	Body B	Brass	Electroless nickel plated
4	Body B	Brass	Electroless nickel plated
5	Needle	Brass	Electroless nickel plated
6	Seat ring	Brass	Electroless nickel plated
7	Spring	Steel wire ⁽¹⁾	
8	U seal	HNBR	
9	U seal	HNBR	
10	Cassette	—	
11	Seal	NBR	
12	O-ring	NBR	

Component Parts

No.	Description	Material	Note
13	O-ring	NBR	
14	O-ring	NBR	
15	O-ring	NBR	
16	O-ring	NBR	
17	Spacer	—	
18	Gasket	NBR, Stainless steel	
19	Retaining ring for hole type C	Tool steel	

Note 1) ASD230F: Stainless steel

Dual Speed Controller Adjustable by Flat Head Screwdriver with One-touch Fitting **ASD** **F-D Series**

Dimensions

Metric size

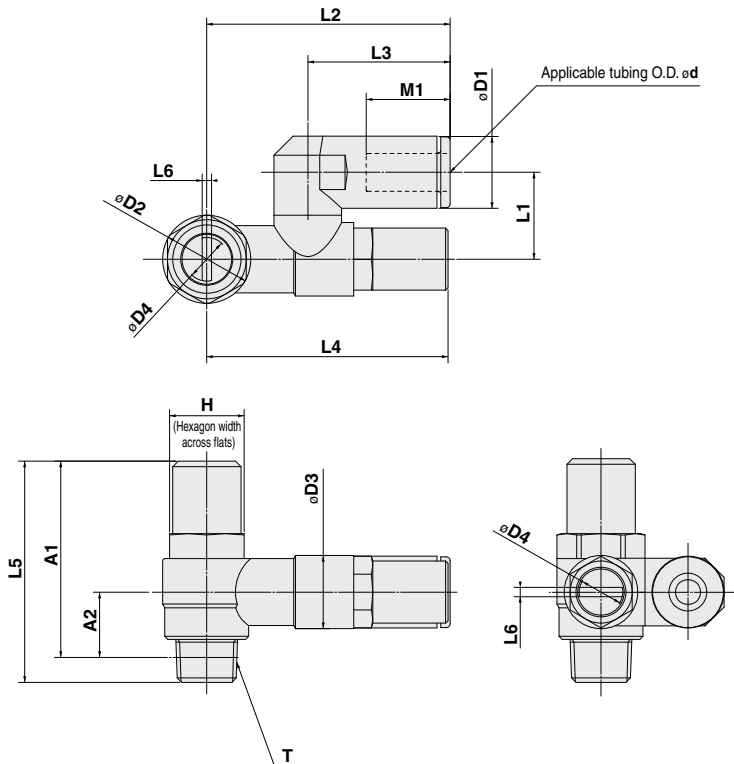

- AS-F
- TMH
- ASD
- AS
- AS-FE
- KE
- AS-FG
- AS-FP
- AS-FM
- AS-D
- AS-T
- ASP
- ASN
- AQ
- ASV
- AK
- VCHC
- ASR
- ASQ

Metric Size

Model	d	T	H	D1	D2	D3	D4	L1	L2	L3	L4	L5	L6	A1*	A2*	M1	Weight (g)
ASD230F-M5-04D	4	M5 x 0.8	8	9.3	9.6	10	4.7	11.7	29.4	17.5	30.7	31	0.7	27.4	7.8	12.9	17
ASD230F-M5-06D	6			11.6					20.6	13.7						18	
ASD330F-01-06SD	6	R 1/8	12	11.6	14.2	11.8	7.2	14	38.5	22.9	38.9	34.7	1.2	31.6	10.6	13.7	36
ASD330F-01-08SD	8			15.2				28.2	38.2	18.5						38	
ASD430F-02-06SD	6	R 1/4	17	12.8	18.5	15	7.2	18	43.5	25.2	41.7	40.2	1.2	34.7	11	17	72
ASD430F-02-08SD	8			15.2				28.2	41.7	18.5						74	
ASD430F-02-10SD	10	R 1/4	19	18.5	23	19.8	9.8	19.7	49.3	31	53.7	54.8	1.2	49.3	15.4	21	77
ASD530F-02-06SD	6			20.3				48.3	25.2	17						107	
ASD530F-02-08SD	8	R 1/4	19	15.2	23	19.8	9.8	20.3	51.3	28.2	53.7	54.8	1.2	49.3	15.4	18.5	109
ASD530F-02-10SD	10			23.1				54.1	32.6	21						113	
ASD530F-02-12SD	12	R 3/8	19	20.9	23	19.8	9.8	23.1	55.9	34.4	53.7	52.6	1.2	47.4	14	22	116
ASD530F-03-06SD	6			20.3				48.3	25.2	17						116	
ASD530F-03-08SD	8	R 3/8	19	15.2	23	19.8	9.8	20.3	51.3	28.2	53.7	52.6	1.2	47.4	14	18.5	135
ASD530F-03-10SD	10			23.1				54.1	32.6	21						140	
ASD530F-03-12SD	12	R 1/2	24	20.9	28.6	26.5	12.4	23.1	55.9	34.4	69.1	62.9	1.2	55.8	18.6	22	143
ASD630F-04-10SD	10			25.9				64.3	32.6	21						254	
ASD630F-04-12SD	12	R 1/2	24	18.5	28.6	26.5	12.4	25.9	66.1	34.4	69.1	62.9	1.2	55.8	18.6	22	256
ASD630F-04-12SD	12			25.9				66.1	34.4	22						256	

* Reference dimensions of M5 x 0.8, R threads after installation.

ASD F-D Series

Dimensions

Inch size

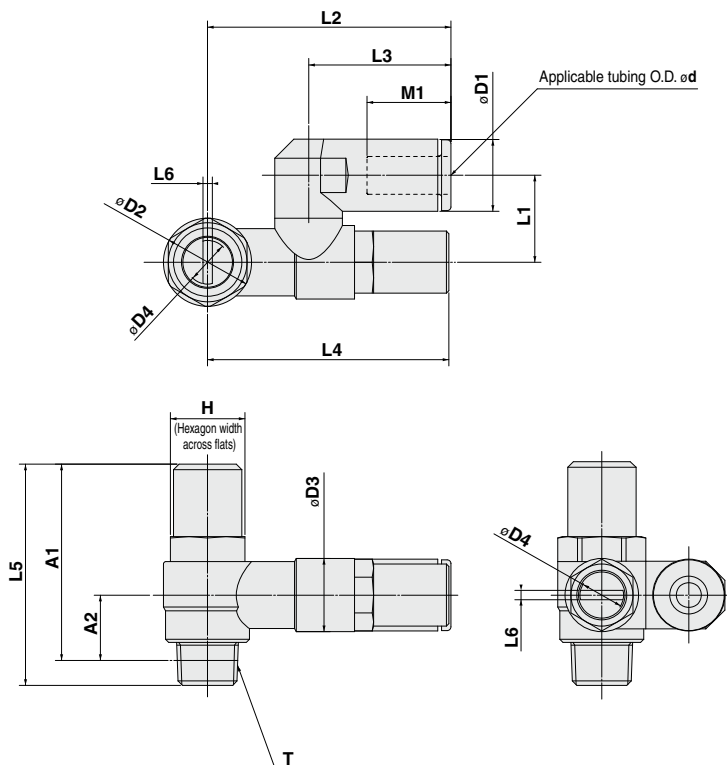

Inch Size

Model	d	T	H	D1	D2	D3	D4	L1	L2	L3	L4	L5	L6	A1*	A2*	M1	Weight (g)
ASD230F-U10/32-01D	1/8"	10-32 UNF	8	8.4	9.6	10	4.7	11.7	29.4	17.5	30.7	31	0.7	27.4	7.8	12.9	17
ASD230F-U10/32-03D	5/32"			9.3					18								
ASD230F-U10/32-05D	3/16"			11.4					16.5								
ASD230F-U10/32-07D	1/4"			12					13.5								
ASD330F-N01-05SD	3/16"	NPT 1/8	12.7	11.6	14.2	11.8	7.2	14	38.5	23.9	38.9	34.7	1.2	31.6	10.6	16.5	37
ASD330F-N01-07SD	1/4"			13.2					17								
ASD330F-N01-09SD	5/16"			15.2					18.5								
ASD430F-N02-07SD	1/4"			13.2					17								
ASD430F-N02-09SD	5/16"	NPT 1/4	17.5	15.2	18.5	15	7.2	18	46.5	28.2	41.7	40.2	1.2	34.7	11	18.5	74
ASD430F-N02-11SD	3/8"			18.5					21								
ASD530F-N02-07SD	1/4"			13.2					17								
ASD530F-N02-09SD	5/16"			15.2					18.5								
ASD530F-N02-11SD	3/8"	NPT 1/4	19	18.5	23	19.8	9.8	20.3	51.3	28.2	53.7	54.8	1.2	49.3	15.4	18.5	33
ASD530F-N03-07SD	1/4"			13.2					17								
ASD530F-N03-09SD	5/16"			15.2					18.5								
ASD530F-N03-11SD	3/8"			18.5					21								
ASD630F-N04-11SD	3/8"	NPT 1/2	23.8	18.5	28.6	26.5	12.4	25.9	64.3	32.6	69.1	62.9	1.2	55.8	18.6	21	256
				21													

* Reference dimensions of 10-32UNF and NPT threads after installation.

Speed Controller Adjustable by Flat Head Screwdriver: Standard Type Elbow Type (Metal Body)

AS□2□0-D Series



Model/Specifications



Specifications	Model	AS12□0-M5	AS12-□0-U10□2	AS22□0-□01	AS22□0-□02	AS32□0-□02	AS32□0-□03	AS42□0-□04
Port size		M5 x 0.8	10-32 UNF	1/8	1/4	1/4, 3/8 <small>Note 4)</small>	3/8	1/2
Fluid		Air						
Proof pressure		1.5 MPa						
Max. operating pressure		1 MPa						
Min. operating pressure		0.1 MPa						
Ambient and fluid temperature		-5 to 60°C (No freezing)						
Controlled flow	Flow rate (L/min (ANR))	105	230	460	920	1700		
	Free flow							
Critical pressure ratio	Sonic Conductance (dm ³ /s/bar)	0.32	0.7	1.4	2.8	5.2		
	Controlled flow	0.2	0.25	0.3	0.25	0.25		
Critical pressure ratio	Free flow	0.4	0.2	0.3	0.2	0.2		

Note 1) Flow rate values are measured at 0.5 MPa and 20°C.
 Note 2) Meter-out and meter-in types can be visually differentiated by the flow direction symbol on the resin body.
 Note 3) Brass parts are all electroless nickel plated, provided as standard.
 Note 4) Female thread port size (valve side) is 3/8 for AS32□0-□02.

How to Order

AS 2 2 0 0 - 01 - S D

Symbol

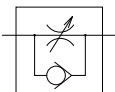

Body size

1	M5 standard
2	1/8, 1/4 standard
3	3/8 standard
4	1/2 standard

Elbow

Control

0	Meter-out
1	Meter-in

Type adjustable by flat head screwdriver

With seal

Note) In case that connecting port is either M5 or 10-32 UNF thread, it is not available with seal. With gasket is provided as standard.

Port size

Symbol	Cylinder side	In the side of solenoid valve
M5	M5 x 0.8	M5 x 0.8
01	R 1/8	Rc 1/8
02	R 1/4	Rc 1/4 <small>Note 1)</small>
		Rc 3/8 <small>Note 2)</small>
03	R 3/8	Rc 3/8
04	R 1/2	Rc 1/2
F01	R 1/8	G 1/8
F02	R 1/4	G 1/4 <small>Note 1)</small>
		G 3/8 <small>Note 2)</small>
F03	R 3/8	G 3/8
F04	R 1/2	G 1/2
U10/32	10-32 UNF	10-32 UNF
N01	NPT 1/8	NPT 1/8
N02	NPT 1/4	NPT 1/4 <small>Note 1)</small>
		NPT 3/8 <small>Note 2)</small>
N03	NPT 3/8	NPT 3/8
N04	NPT 1/2	NPT 1/2

Note 1) AS22□0-□02
 Note 2) AS32□0-□02

Caution

Be sure to read this before handling the products. Refer to back page 50 for Safety Instructions and pages 543 to 546 for Flow Control Equipment Precautions.

- AS-F
- TMH
- ASD
- AS
- AS-FE
- KE
- AS-FG
- AS-FP
- AS-FM
- AS-D
- AS-T
- ASP
- ASN
- AQ
- ASV
- AK
- VCHC
- ASR
- ASQ

AS□2□0-D Series

Construction

Meter-out
M5 type
U10/32 type

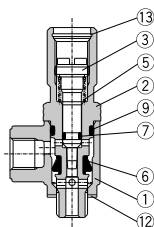

AS3200-02-D

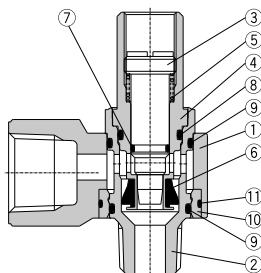

Meter-in
M5 type
U10/32 type

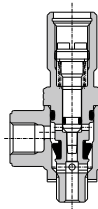

AS3210-02-D

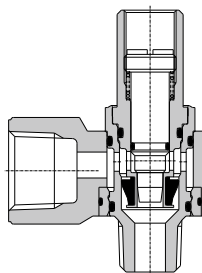

Component Parts

No.	Description	Material	Note
1	Body A	Zinc alloy	Chromate plated
2	Body B	Brass	Electroless nickel plated
3	Needle	Brass	Electroless nickel plated
4	Seat ring	Brass	Electroless nickel plated
5	Spring	Steel wire ⁽¹⁾	
6	U seal	HNBR	
7	O-ring	NBR	
8	O-ring	NBR	
9	O-ring	NBR	
10	Bushing	PBT	
11	O-ring	NBR	
12	Gasket	NBR, Stainless steel	
13	Retaining ring for hole type C	Tool steel	

Note 1) M5 and U10/32 type: Stainless steel

Speed Controller Adjustable by Flat Head Screwdriver:
Standard Type, Elbow Type (Metal Body) **AS□2□0-D Series**

Dimensions

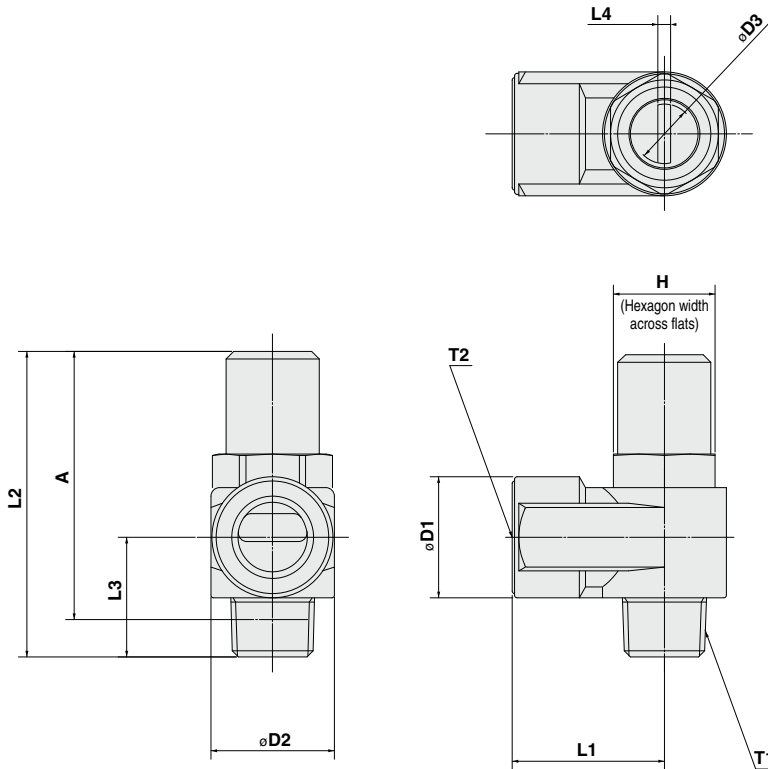

- AS-F
- TMH
- ASD
- AS
- AS-FE
- KE
- AS-FG
- AS-FP
- AS-FM
- AS-D**
- AS-T
- ASP
- ASN
- AQ
- ASV
- AK
- VCHC
- ASR
- ASQ

Dimensions

Model	T1	T2	H	D1	D2	D3	L1	L2	L3	L4	A*	Weight (g)
AS12□0-M5-D	M5 x 0.8	M5 x 0.8	8	9	9	4.7	10	31	10.3	0.7	27.4	13
AS12□0-U10/32-D	10-32 UNF	10-32 UNF										
AS22□0-01-SD	R 1/8	Rc 1/8	12	14.3	14.6	7.2	18	34.7	13.2	1.2	31.6	33
AS22□0-F01-SD		G 1/8										
AS22□0-N01-SD	NPT 1/8	NPT 1/8	12.7	18	19.5	7.2	27.2	40.2	17.5	1.2	36.7	72
AS22□0-02-SD	R 1/4	Rc 1/4										
AS22□0-F02-SD	R 1/4	G 1/4	17	18	19.5	7.2	27.2	40.2	17.5	1.2	36.7	72
AS22□0-N02-SD		NPT 1/4										
AS32□0-02-SD	R 1/4	Rc 3/8	19	22.5	24.3	9.8	30	54.8	21.9	1.2	49.3	123
AS32□0-F02-SD		G 3/8										
AS32□0-N02-SD	NPT 1/4	NPT 3/8	17.5	18	22.5	24.3	30	52.6	19.7	1.2	47.4	128
AS32□0-03-SD	R 3/8	Rc 3/8										
AS32□0-F03-SD	R 3/8	G 3/8	19	22.5	24.3	9.8	30	52.6	19.7	1.2	47.4	128
AS32□0-N03-SD		NPT 3/8										
AS42□0-04-SD	R 1/2	Rc 1/2	24	27.5	28.5	12.4	38.5	62.9	25.8	1.2	55.8	222
AS42□0-F04-SD		G 1/2										
AS42□0-N04-SD	NPT 1/2	NPT 1/2	23.8									

* Reference thread dimensions after installation.