

Speed Controller with Uni One-touch Fitting

Push-lock type

AS Series

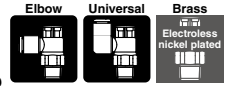

New-stand male threads for piping that reduces the screw-in time by 1/3.

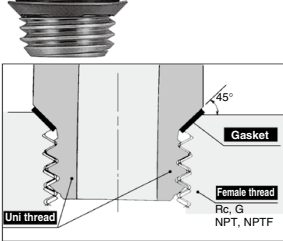

Shape of Uni thread ridge

Use of the chamfered surface of the female thread as the seat surface and adoption of gaskets made by laminating NBR on both surfaces of stainless steel plates achieve secure sealing regardless of the difference of diameters due to the female thread type, deviations due to the tolerance, or the size of the chamfered corner. (Any standard chamfered female thread can be used.)

A ridge shape has been created as a Uni thread for common applications for Rc, G, NPT and NPTF.

The gasket seal method drastically cuts piping work-hours.

Flow Direction Symbols on Body

	Meter-out	Meter-in
Symbol		

Caution

Be sure to read this before handling the products. Refer to back page 50 for Safety Instructions, pages 543 to 546 for Flow Control Equipment Precautions, and pages 573 to 575 for Specific Product Precautions.

Model

Model		Uni thread size	Applicable tubing O.D.														
Elbow type	Universal type		Metric size					Inch size									
			3.2	4	6	8	10	12	16	1/8"	5/32"	1/4"	5/16"	3/8"	1/2"		
AS22□1F-U01	AS23□1F-U01	1/8	●	●	●	●	●(Note)					●	●	●	●		
AS22□1F-U02	AS23□1F-U02	1/4	●(Note)	●	●	●	●					●(Note)	●	●	●	●	
AS32□1F-U02	AS33□1F-U02	1/4			●	●	●							●	●	●	
AS32□1F-U03	AS33□1F-U03	3/8			●	●	●	●						●	●	●	
AS42□1F-U04	AS43□1F-U04	1/2					●	●	●(Note)							●	●

Note) Universal type is not available.

Specifications

Fluid	Air
Proof pressure	1.5 MPa
Max. operating pressure	1 MPa
Min. operating pressure	0.1 MPa
Ambient and fluid temperature	-5 to 60°C (No freezing)
Applicable tubing material	Nylon, Soft nylon, Polyurethane (Note)

Note) Use caution at the max. operating pressure when using soft nylon or polyurethane tubing. (Refer to pages 464 and 465 for details.)

Flow Rate and Sonic Conductance

Model	AS22□1F-U01 AS23□1F-U01			AS22□1F-U02 AS23□1F-U02			AS32□1F AS33□1F		AS42□1F AS43□1F					
	3.2	4	6	3.2	4	6	8	10	10	16				
Tubing O.D.	Metric size	3.2	4	6	8	10	12	16	1/8"	5/32"	1/4"	5/16"	3/8"	1/2"
	Inch size	1/8"	5/32"	1/4"	1/8"	5/32"	—	1/4"	5/16"	3/8"	3/8"	3/8"	1/2"	
C values: Sonic conductance dm ³ (s-bar)	Free flow	0.4	0.6	0.6	0.7	1.0	1.3	1.5	1.6	1.7	2.5	4.4	4.8	
	Controlled flow	0.4	0.7	0.8	0.6	0.9		1.3	2.1	2.4	3.3	4.4	4.9	
b values: Critical pressure ratio	Free flow	0.2	0.3		0.3		0.4		0.4		0.3		0.3	
	Controlled flow	0.2	0.3		0.3				0.3				0.3	

Note) C and b values are for controlled flow with the needle fully open and free flow with the needle fully closed.

AS Series

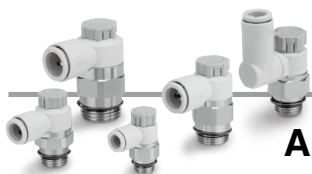

How to Order



AS 2 2 0 1 F - U01 - 06 A

Body size

2	1/8, 1/4
3	3/8
4	1/2

Type

2	Elbow
3	Universal

Control type

0	Meter-out
1	Meter-in

* Meter-out and meter-in types can be visually identified by color of the knob.
Meter-out: Gray
Meter-in: Light blue

With One-touch fitting

Port size

U01	Uni 1/8
U02	Uni 1/4
U03	Uni 3/8
U04	Uni 1/2

• Push-lock type

• Applicable tubing O.D. ^{Note 1)}

Metric size		Inch size	
Tubing O.D.		Tubing O.D.	
23	ø3.2 ^{Note 2)}	01	ø1/8"
04	ø4	03	ø5/32"
06	ø6	07	ø1/4"
08	ø8	09	ø5/16"
10	ø10	11	ø3/8"
12	ø12	13	ø1/2"
16	ø16		

Note 1) For selecting applicable tubing O.D., refer to the "Model" on page 625. Metric size and inch size types can be visually identified by color of the release button.

Metric size: Light gray
Inch size: Orange

Note 2) Use ø1/8" tube.

Needle Valve/Flow Rate Characteristics

AS2201F-U01, AS2211F-U01
AS2301F-U01, AS2311F-U01

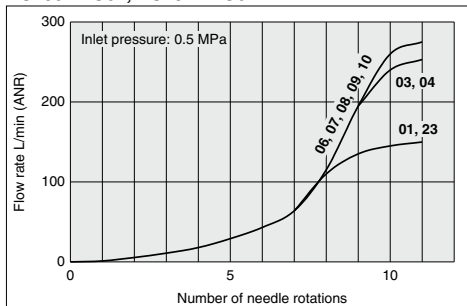

AS2201F-U02, AS2211F-U02
AS2301F-U02, AS2311F-U02

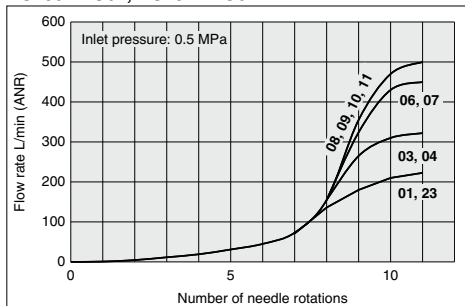

AS3201F, AS3211F
AS3301F, AS3311F

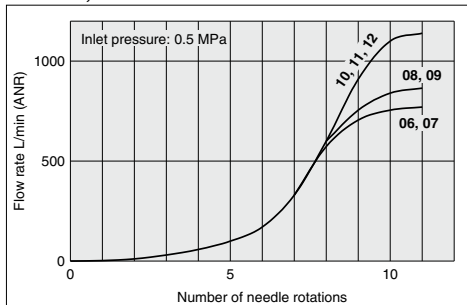

AS4201F, AS4211F
AS4301F, AS4311F

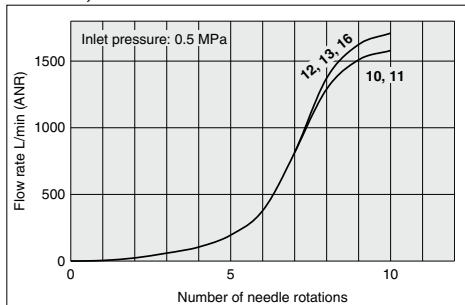

Note) The numbers above the flow rate characteristic curves in the charts show the applicable tubing outside diameter as defined by the product number.

Construction

Elbow type

Seal method: Gasket seal
For Uni thread

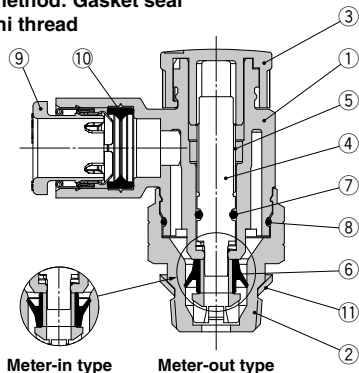

Component Parts

No.	Description	Material	Note
1	Body A	PBT	
2	Body B	Brass	Electroless nickel plating
3	Knob	POM	
4	Needle	PBT	
5	Needle guide	Brass	Electroless nickel plating
6	U-seal	HNBR	
7	O-ring	NBR	
8	O-ring	NBR	
9	Cassette	—	
10	Seal	NBR	
11	Gasket	NBR/Stainless steel	

Universal type

Seal method: Gasket seal
For Uni thread

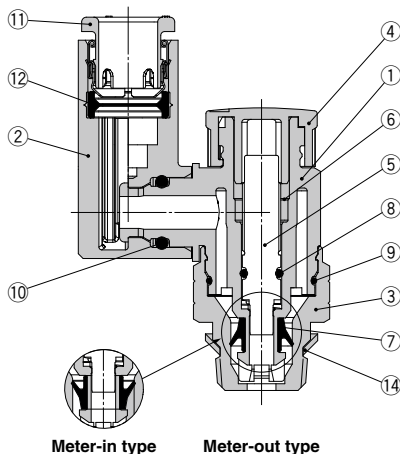
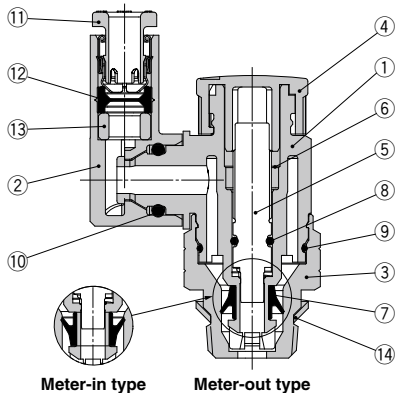

Component Parts

No.	Description	Material	Note
1	Body A	PBT	
2	Elbow body	PBT	
3	Body B	Brass	Electroless nickel plating
4	Knob	POM	
5	Needle	PBT	
6	Needle guide	Brass	Electroless nickel plating
7	U-seal	HNBR	
8	O-ring	NBR	
9	O-ring	NBR	
10	O-ring	NBR	
11	Cassette	—	
12	Seal	NBR	
13	Spacer <small>(Note)</small>	—	
14	Gasket	NBR/Stainless steel	

Note) Used only for the AS22□1F-U01-23A.

AS-F

TMH

ASD

AS

AS-FE

KE

AS-FG

AS-FP

AS-FM

AS-D

AS-T

ASP

ASN

AQ

ASV

AK

VCHC

ASR

ASQ

AS Series

Dimensions/ Elbow type

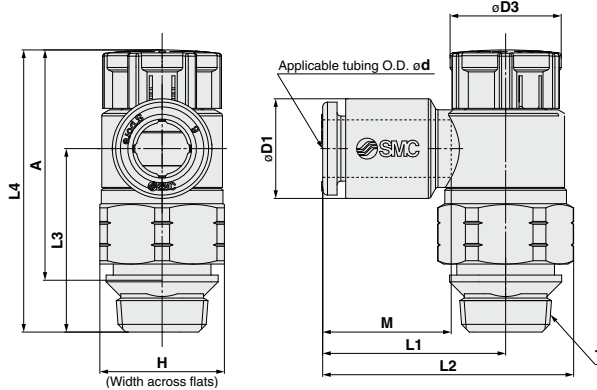

Metric Size

Model	d	T Uni thread	H	D1	D3	L1	L2	L3	L4 Note 1)		A Note 2)		M	Weight [g]
									Unlocked	Locked	Unlocked	Locked		
AS22□1F-U01-23A	3.2	1/8	13	7.2	12	19.1	26.2	19.1	30.6	29.2	25.8	24.4	13.3	9
AS22□1F-U01-04A	4			8.2										
AS22□1F-U01-06A	6			10.4										
AS22□1F-U01-08A	8			13.2										
AS22□1F-U01-10A	10	15.9	25.3	32.4										
AS22□1F-U02-23A	3.2	1/4	17	7.2	13	23.4	32.7	22.6	36.6	35	30.2	28.6	13.3	17
AS22□1F-U02-04A	4			8.2										
AS22□1F-U02-06A	6			10.4										
AS22□1F-U02-08A	8			13.2										
AS22□1F-U02-10A	10	15.9	26.9	36.2										
AS32□1F-U02-06A	6	1/4	19	10.4	16.6	21.8	32.1	36.4	50	48.4	43.6	42	13.3	39
AS32□1F-U02-08A	8			13.2										
AS32□1F-U02-10A	10			15.9										
AS32□1F-U02-12A	12			18.5										
AS32□1F-U03-06A	6	3/8	19	10.4	16.6	21.8	32.1	28.7	42.3	40.7	35.9	34.3	13.3	39
AS32□1F-U03-08A	8			13.2										
AS32□1F-U03-10A	10			15.9										
AS32□1F-U03-12A	12			18.5										
AS42□1F-U04-10A	10	1/2	24	15.9	18.8	27.4	40.3	36.2	50.8	49.2	42.2	40.6	15.6	52
AS42□1F-U04-12A	12			18.5										
AS42□1F-U04-14A	14			21.2										
AS42□1F-U04-16A	16			23.8										

Note 1) Reference dimensions Note 2) Reference dimensions of threads after installation

Inch Size

Model	d	T Uni thread	H	D1	D3	L1	L2	L3	L4 Note 1)		A Note 2)		M	Weight [g]
									Unlocked	Locked	Unlocked	Locked		
AS22□1F-U01-01A	1/8"	1/8	13	7.2	12	19.1	26.2	19.1	30.6	29.2	25.8	24.4	13.3	9
AS22□1F-U01-03A	5/32"			8.2										
AS22□1F-U01-07A	1/4"			11.2										
AS22□1F-U01-09A	5/16"			13.2										
AS22□1F-U02-01A	1/8"	1/4	17	7.2	13	23.4	32.7	22.6	36.6	35	30.2	28.6	13.3	17
AS22□1F-U02-03A	5/32"			8.2										
AS22□1F-U02-07A	1/4"			11.2										
AS22□1F-U02-09A	5/16"			13.2										
AS22□1F-U02-11A	3/8"	15.5	26.4	35.7										
AS32□1F-U02-07A	1/4"	1/4	19	11.2	16.6	21.8	32.1	36.4	50	48.4	43.6	42	13.3	39
AS32□1F-U02-09A	5/16"			13.2										
AS32□1F-U02-11A	3/8"			15.5										
AS32□1F-U03-07A	1/4"			11.2										
AS32□1F-U03-09A	5/16"	3/8	19	13.2	16.6	22.7	33	28.7	42.3	40.7	35.9	34.3	14.2	39
AS32□1F-U03-11A	3/8"			15.5										
AS42□1F-U04-11A	3/8"			15.5										
AS42□1F-U04-13A	1/2"			19.3										

Note 1) Reference dimensions Note 2) Reference dimensions of threads after installation



Dimensions/ **Universal type**

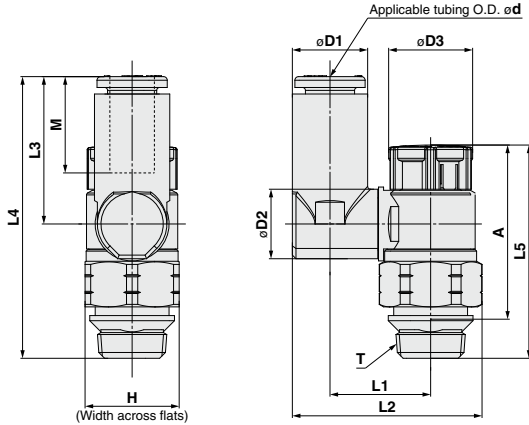

Metric Size

Model	d	T Uni thread	H	D1	D2	D3	L1	L2	L3	L4	L5 <small>Note 1)</small>		A <small>Note 2)</small>		M	Weight [g]
											Unlocked	Locked	Unlocked	Locked		
AS23□1F-U01-23A	3.2	1/8	13	7.2	9.6	12	13.3	24	17.5	36	30.6	29.2	25.8	24.4	13.3	9
AS23□1F-U01-04A	4			8.2			25.1	10								
AS23□1F-U01-06A	6			10.4			26.2	38.8								11
AS23□1F-U01-08A	8	1/4	17	13.2	12.9	13	16.4	30.1	17.5	40.1	36.6	35	30.2	28.6	14.2	11
AS23□1F-U02-04A	4			8.2			29.9	40.1							18	
AS23□1F-U02-06A	6			11.2			33.8	43.9							19	
AS23□1F-U02-08A	8			13.2			34.9	46							19	
AS23□1F-U02-10A	10			15.9			38.1	47.3							20.9	
AS33□1F-U02-06A	6			11.2			36	57.8							20.2	
AS33□1F-U02-08A	8	13.2	37.1	59.9	16.6	23	41.2	26.1	62.5	42.3	40.7	43.6	42	14.2	31	
AS33□1F-U02-10A	10	15.9	42.5	64.7										32		
AS33□1F-U02-12A	12	18.5	42.5	64.7										34		
AS33□1F-U03-06A	6	3/8	19	11.2	12.9	16.6	20.2	36	21.4	50.1	42.3	40.7	35.9	34.3	13.3	31
AS33□1F-U03-08A	8			13.2			37.1	52.2							14.2	
AS33□1F-U03-10A	10			15.9			41.2	54.8							15.6	
AS33□1F-U03-12A	12			18.5			42.5	57							17	
AS43□1F-U04-10A	10			15.9			46.4	61.2							15.6	54
AS43□1F-U04-12A	12			18.5			48.3	63.4							17	56

Note 1) Reference dimensions Note 2) Reference dimensions of threads after installation

Inch Size

Model	d	T Uni thread	H	D1	D2	D3	L1	L2	L3	L4	L5 <small>Note 1)</small>		A <small>Note 2)</small>		M	Weight [g]
											Unlocked	Locked	Unlocked	Locked		
AS23□1F-U01-01A	1/8"	1/8	13	7.2	9.6	12	13.3	24	17.5	36	30.6	29.2	25.8	24.4	13.3	9
AS23□1F-U01-03A	5/32"			8.2			25.1	10								
AS23□1F-U01-07A	1/4"			11.2			29.1	38.7								11
AS23□1F-U01-09A	5/16"	1/4	17	13.2	12.9	13	16.4	30.1	17.5	40.1	36.6	35	30.2	28.6	14.2	11
AS23□1F-U02-03A	5/32"			8.2			29.9	40.1							17	
AS23□1F-U02-07A	1/4"			11.2			33.8	43.9							19	
AS23□1F-U02-09A	5/16"			13.2			34.9	46							19	
AS23□1F-U02-11A	3/8"			15.9			38.1	47.3							20.9	
AS33□1F-U02-07A	1/4"			11.2			36	57.8							20.2	
AS33□1F-U02-09A	5/16"	13.2	37.1	59.9	16.6	23	41.2	26.1	62.5	42.3	40.7	43.6	42	14.2	31	
AS33□1F-U02-11A	3/8"	15.9	42.5	64.7										32		
AS33□1F-U03-09A	5/16"	11.2	37.1	52.2										15.6		
AS33□1F-U03-11A	3/8"	13.2	41.2	54.8	17											
AS33□1F-U03-13A	7/16"	15.9	42.5	57	17											
AS43□1F-U04-11A	3/8"	15.9	46.4	61.2	15.6	54										
AS43□1F-U04-13A	1/2"	18.5	48.3	63.4	17	56										

Note 1) Reference dimensions Note 2) Reference dimensions of threads after installation



AS Series Specific Product Precautions 1

Be sure to read this before handling the products.

Refer to back page 50 for Safety Instructions and pages 543 to 546 for Flow Control Equipment Precautions.

Design and Selection

Warning

1. Check the specifications.

The products in this catalog are designed to be used in compressed air systems (including vacuum) only. If the products are used in an environment where pressure or temperature is out of the specified range, damage and/or malfunction may result. Do not use under such conditions. (Refer to the specifications.)

Please contact SMC when using a fluid other than compressed air (including vacuum).

We do not guarantee against any damage if the product is used outside of the specification range.

2. The products in this catalog are not designed for the use as stop valve with zero air leakage.

A certain amount of leakage is allowed in the product's specifications.

Tightening the needle to reduce leakage to zero may result in equipment damage.

3. Do not disassemble the product or make any modifications, including additional machining.

It may cause human injury and/or an accident.

4. The flow rate characteristics for each product are representative values.

The flow rate characteristics are characteristics of each individual product. Actual values may differ depending on the piping, circuitry, pressure conditions, etc.

5. Sonic conductance (C) and critical pressure ratio (b) values for products are representative values.

The speed controller's controlled flow values are with the needle fully open and free flow with the needle fully closed.

6. Check if PTFE can be used in application.

PTFE powder (Polytetrafluoroethylene resin) is included in the seal material for piping taper thread of male thread type. Confirm that the use of it will not cause any adverse effect on the system.

Please contact SMC if the Material Safety Data Sheet (MSDS) is required.

7. Speed controller is designed to control the speed of the actuator.

When it is used for adjusting the flow rate of the air blow, use a restrictor without check valve function (X214 or X21).

Mounting

Warning

1. Operation Manual

Install the products and operate them only after reading the Operation Manual carefully and understanding its contents. Also, keep the manual where it can be referred to as necessary.

2. Ensure sufficient space for maintenance activities.

When installing the products, allow access for maintenance.

Mounting

Warning

3. Tighten threads with the proper tightening torque.

When installing the products, follow the listed proper torque.

4. After pushing the knob down to lock, confirm that it is locked.

It should not be possible to rotate the knob to the right or to the left. If the knob is pulled with force, it may break. Do not pull the knob with excessive force.

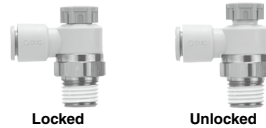

5. Check the degree of rotation of the needle valve.

The products in this catalog are retainer type so that the needle is not removed completely. Over rotation will cause damage.

6. Do not use tools such as pliers to rotate the knob.

It can cause idle rotation of the knob or damage.

7. Verify the air flow direction.

Mounting backward is dangerous, because the speed adjustment needle will not work and the actuator may lurch suddenly.

8. Adjust the speed by opening the needle slowly from the fully closed state.

Loose needle valves may cause unexpected sudden actuator lurching.

When a needle valve is turned clockwise, it is closed and actuator speed decreases. When a needle valve is turned counter-clockwise, it is open and actuator speed increases.

9. Do not apply excessive force or shock to the body or fittings with an impact tool.

It can cause damage or air leakage.

10. For handling One-touch fittings, refer to the Fittings and Tubing Precautions on pages 13 to 17.

11. Tubing O.D. ø2

Tubing other than that from SMC cannot be used, because it may result in inability to connect the tube, air leakage after connecting the tube or disconnection of the tube.

12. To install/remove the product, use an appropriate wrench to tighten/loosen at the supplied nut on body B.

Do not apply torque at other points as the product may be damaged. Rotate body A manually for positioning after installation.

AS-F
TMH
ASD
AS
AS-FE
KE
AS-FG
AS-FP
AS-FM
AS-D
AS-T
ASP
ASN
AQ
ASV
AK
VCHC
ASR
ASQ



AS Series Specific Product Precautions 2

Be sure to read this before handling the products.

Refer to back page 50 for Safety Instructions and pages 543 to 546 for Flow Control Equipment Precautions.

Mounting

Warning

13. Do not use body A and/or elbow body for applications involving continuous rotation.

Body A and the fitting section may be damaged.

Elbow

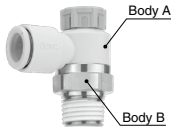

Universal

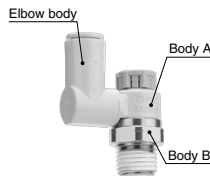

Caution

For M5, 10-32UNF

Tightening method

First, tighten it by hand, then give it an additional 1/6 turn to 1/4 turn with a wrench. A reference value for the tightening torque is 1 to 1.5 N·m.

Note) Excessive tightening may damage the thread portion or deform the gasket and cause air leakage.

If the screw is too shallowly screwed in, it may come loose or air may leak.

Chamfered area for female thread

1. Conforming to ISO 16030 (air pressure fluid dynamics – connection – ports and stud ends), the chamfered dimensions shown in the table below are recommended.

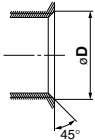

Female thread size	Chamfered dimension ϕD (Recommended value)
M5	5.1 to 5.4
10-32UNF	5.0 to 5.3

2. This product has a stopper for fully close in rotating direction. Excess torque may break the stopper. Table below shows the maximum allowable torque of the knob.

Body size	Maximum allowable torque [N·m]
M5	0.05
1/8	0.07
1/4	0.16
3/8	0.2
1/2	0.4

3. When performing the piping work, turn the tightening tool in the horizontal direction to the hexagon across flats of the body B so that any moment is not applied to the body A. If the tool is in contact with the body A, this may cause the body B to come off.

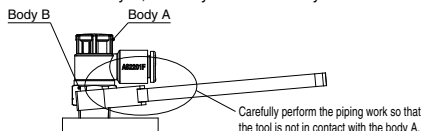

Caution

For R, NPT Thread (With sealant)

Tightening method

1. The proper tightening torques of the fittings are as shown in the table below. As a guide, tighten by hand, then turn it two or three turns with a wrench. Check the dimensions of each product for the hexagon width across flats.

Connection thread size	Proper tightening torque [N·m]
NPT, R1/8	3 to 5
NPT, R1/4	8 to 12
NPT, R3/8	15 to 20
NPT, R1/2	20 to 25

Chamfered area for female thread

By chamfering as shown in the table below, machining of threads is easier and effective for burr prevention.

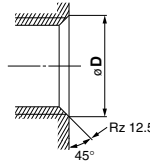

Connection thread size	Chamfered dimension ϕD (Recommended value)	
	Rc	NPT, NPTF
1/8	10.2 to 10.4	10.5 to 10.7
1/4	13.6 to 13.8	14.1 to 14.3
3/8	17.1 to 17.3	17.4 to 17.6
1/2	21.4 to 21.6	21.7 to 21.9

* For Uni thread, Rz 12.5 is necessary for sealing at the chamfered part.

For R, NPT, G Thread (Face seal type)

Tightening method

First, tighten the threaded portion by hand, then use a proper wrench, which could be suitable for the width across flats of the hexagon body, to tighten it further at a wrench tightening angle shown in the table below. For a tightening torque guide, refer to the table below. Check the dimensions of each product for the hexagon width across flats.

1. Tighten fittings with face seal using the proper tightening torques in the table below.

Connection thread size (R, NPT, G)	Proper tightening torque [N·m]
1/16, 1/8	3 to 5
1/4	8 to 12
3/8	15 to 20
1/2	20 to 25

2. Insufficient tightening may cause seal failure, or loosen the threads.

3. Reuse

- Normally, fittings with face seal can be reused 6 to 10 times.
- The seal ring cannot be replaced.



AS Series

Specific Product Precautions 3

Be sure to read this before handling the products.

Refer to back page 50 for Safety Instructions and pages 543 to 546 for Flow Control Equipment Precautions.

Mounting

⚠ Caution

For R, NPT, G Thread (Face seal type)

Chamfered area for female thread (Recommended value)

- Conforming to ISO 16030-2001, the chamfered dimensions shown in the table below are recommended. By chamfering as shown in the table below, machining of threads is easier and effective for burr prevention.

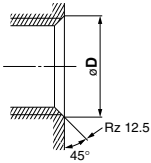

Nominal thread size	Chamfered dimension ϕD	
	Min.	Max.
1/8	9.8	10.2
1/4	13.3	13.7
3/8	16.8	17.2
1/2	21.0	21.4

- Use G external threads with G internal threads.

How to distinguish between G, R and NPT threads

For R, NPT thread

R: Without slit
NPT: With slit

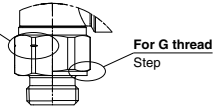

For Uni Thread

Tightening method

- First, tighten the threaded portion by hand, then use a proper wrench, which could be suitable for the width across flats of the hexagon body, to tighten it further at a wrench tightening angle shown in the table below. For a tightening torque guide, refer to the table below.

Connection Female Thread: Rc, NPT, NPTF

Uni thread size	Wrench tightening angle after hand-tightening [deg]	Tightening torque [N·m]
1/8	30 to 60	3 to 5
1/4	30 to 60	8 to 12
3/8	15 to 45	14 to 16
1/2	15 to 30	20 to 22

Connection Female Thread: G

Uni thread size	Wrench tightening angle after hand-tightening [deg]	Tightening torque [N·m]
1/8	30 to 45	3 to 4
1/4	15 to 30	4 to 5
3/8	15 to 30	8 to 9
1/2	15 to 30	14 to 15

- The gasket can be reused up to 6 to 10 times.

Chamfered area for female thread

By chamfering as shown in the table below, machining of threads is easier and effective for burr prevention.

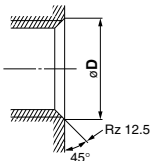

Connection thread size	Chamfered dimension ϕD (Recommended value)		
	G	Rc	NPT, NPTF
1/8	10.2 to 10.6	10.2 to 10.4	10.5 to 10.7
1/4	13.6 to 14.0	13.6 to 13.8	14.1 to 14.3
3/8	17.1 to 17.5	17.1 to 17.3	17.4 to 17.6
1/2	21.4 to 21.8	21.4 to 21.6	21.7 to 21.9

* For Uni thread, Rz 12.5 is necessary for sealing at the chamfered part.

Piping Threads with Sealant

⚠ Caution

- If the fitting is tightened with excessive torque, a large amount of sealant will seep out. Remove the excess sealant.
- Insufficient tightening may loosen the threads, or cause air leakage.
- Reuse
 - Normally, fittings with sealant can be reused 2 to 3 times.
 - To prevent air leakage through the sealant, remove any loose sealant stuck to the fitting by blowing air over the threaded portion.
 - If the sealant no longer provides effective sealing, wrap sealing tape over the sealant before reusing. Do not use the sealant in any form other than a tape type.
- Once the fitting has been tightened, backing it out to its original position often causes the sealant to become defective. Air leakage will occur.
- Use R external threads with Rc internal threads and NPT external threads with NPT internal threads.

Piping

⚠ Caution

- For handling One-touch fittings, refer to the Fittings and Tubing Precautions on pages 13 to 17.
- Preparation before piping

Before piping is connected, it should be thoroughly blown out with air (flushing) or washed to remove chips, cutting oil and other debris from inside the pipe.

- Winding of sealant tape

When screwing together pipes and fittings, etc., be certain that chips from the pipe threads and sealing material is used, not get inside the pipe. Also, when the sealant tape is do, leave approx. 1 thread ridges exposed at the end of the threads.

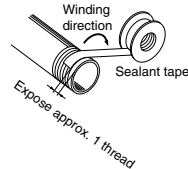

AS-F

TMH

ASD

AS

AS-FE

KE

AS-FG

AS-FP

AS-FM

AS-D

AS-T

ASP

ASN

AQ

ASV

AK

VCHC

ASR

ASQ