

# Speed Controller: Standard Type In-line Type

# AS Series



Compact size saves space.  
Speed may be accurately controlled even at low speeds.  
Constant speed easily set.  
Retainer prevents an accidental loss of needle.



Symbol

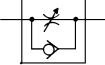

### Caution

Be sure to read this before handling the products.  
Refer to back page 50 for Safety Instructions and pages 543 to 546 for Flow Control Equipment Precautions.

### Model/Flow Rate and Effective Area

Model	Port size	Free flow			Controlled flow			Weight (g)
		Flow rate (L/min (ANR))	Sonic conductance dm <sup>2</sup> /(s bar)	Critical pressure ratio	Flow rate (L/min (ANR))	Sonic conductance dm <sup>2</sup> /(s bar)	Critical pressure ratio	
AS1000-M3	M3 x 0.5	20	0.06	0.15	20	0.06	0.2	4.7
AS1000-M5	M5 x 0.8	90	0.25		80	0.22		33
AS2000-01	1/8	340	0.94	0.35	250	0.7	0.2	90
AS2000-02	1/4	340	0.94		250	0.7		115
AS3000-02	1/4	810	2.3		810	2.3		130
AS3000-03	3/8	810	2.3		810	2.3		124
AS4000-02	1/4	1,670	4.6		1,670	4.6		221
AS4000-03	3/8	1,670	4.6		1,670	4.6		214
AS4000-04	1/2	1,670	4.6		1,670	4.6		205
AS5000-02	1/4	2,840	7.9		2,840	7.9		242
AS5000-03	3/8	4,270	11.9		4,270	11.9		233
AS5000-04	1/2	4,270	11.9		4,270	11.9		224

Note) Flow rate values are measured at 0.5 Mpa and 20°C.

### Specifications

Fluid	Air
Proof pressure (Note)	1.5 MPa (1.05 MPa)
Max. operating pressure (Note)	1 MPa (0.7 MPa)
Min. operating pressure (Note)	0.05 MPa (0.1 MPa)
Ambient and fluid temperature	-5 to 60°C (No freezing)

Note) ( ): Values for AS1000.

### Accessory

Description	Part no.	Applicable model
Nipple	M-5N	AS1000-M5

Note) AS1000 with nipple: AS1000-M5-N

### How to Order

AS **1** 000 - **M5** - **□** - **□**

**Body size**

1	M3, M5 standard
2	1/8, 1/4 standard
3	3/8 standard
4	1/2 standard
5	1/2 standard

**Thread type**

Nil	Metric thread (M3, M5)
N	Rc
F	NPT
	G

**Lock nut option**

Nil	Hexagon lock nut
J (3)	Round lock nut

Note 3) Only for AS1000

**Option**

Nil	Standard (-5 to 60°C)
H (1)	High temperature (-5 to 80°C)
L (2)	Low temperature (-30 to 60°C)
N (3)	With nipple

Note 1) AS5000 is available as special. AS1000 is not applicable.  
Note 2) AS1000, AS2000 are not applicable.  
Note 3) Only for AS1000-M5

**Bore size**

Bore size	Applicable series
M3	M3 x 0.5 AS1000
M5	M5 x 0.8 AS1000
01	1/8 AS2000
02	1/4 AS2000, 3000, 4000, 5000
03	3/8 AS3000, 4000, 5000
04	1/2 AS4000, 5000

### Needle Valve/Flow Rate Characteristics

Note) The flow rate characteristics are representative values.

AS1000-M3

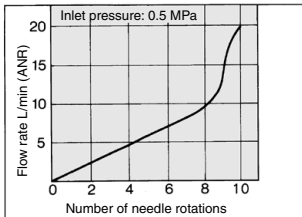

AS1000-M5

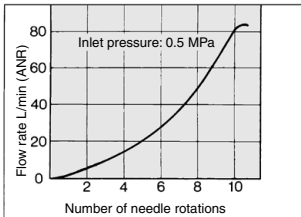

AS2000

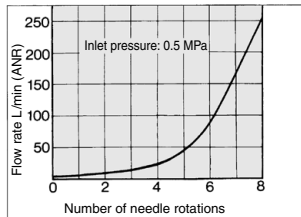

AS3000

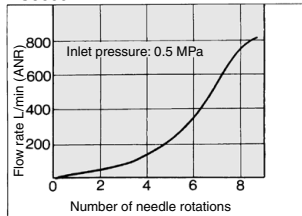

AS4000

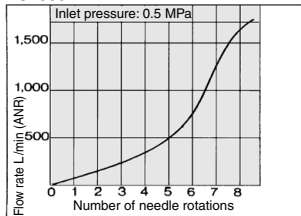

AS5000

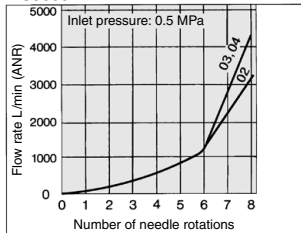

### Construction: AS1000-M3

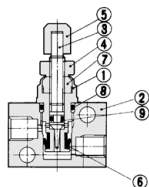

#### Component Parts

No.	Description	Material	Note
1	Body B	Brass	Electroless nickel plated
2	Body	Brass	Electroless nickel plated
3	Needle	Brass	Electroless nickel plated
4	Lock nut	Steel <sup>Note)</sup>	Zinc chromated
5	Handle	Brass	Electroless nickel plated
6	U seal	HNBR	
7	Needle guide	Brass	Electroless nickel plated
8	O-ring	NBR	4.5 x 3 x 0.75
9	O-ring	NBR	2.2 x 0.8 x 0.7

Note) Option: The round lock nut is made of electroless nickel plated brass.

### Construction: AS1000-M5

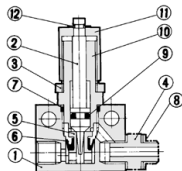

#### Component Parts

No.	Description	Material	Note
1	Body	Zinc alloy	
2	Needle	Stainless steel	
3	Lock nut	Steel <sup>Note)</sup>	
4	Nipple	Stainless steel	

No.	Description	Material	Note
9	O-ring	NBR	
10	Needle guide	Brass	Electroless nickel plated
11	Handle	Brass	Electroless nickel plated
12	E type snap ring	Steel	

Note) Option: The round lock nut is made of electroless nickel plated brass.

#### Replacement Parts

No.	Description	Material	Part no.	Note
5	Valve seat	Brass	1429138	
6	U seal	HNBR	142964-3	
7	O-ring	NBR	KA00327	ø9 x ø7 x ø1
8	Gasket	NBR/Stainless steel	M-5G2	

Note) Construction drawing: AS1000-M5-N  
In case of AS1000-M5, nipples and gaskets are not attached.

AS-F

TMH

ASD

AS

AS-FE

KE

AS-FG

AS-FP

AS-FM

AS-D

AS-T

ASP

ASN

AQ

ASV

AK

VCHC

ASR

ASQ

# AS Series

## Construction: AS2000/3000

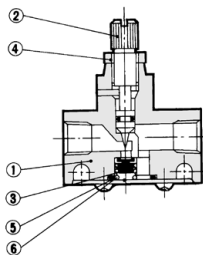

### Component Parts

No.	Description	Parts no.	
		AS2000	AS3000
1	<b>Body</b>	Zinc alloy	Aluminum alloy
2	<b>Needle</b> *	Brass	Brass
4	<b>Lock nut</b> *	Brass	Carbon steel

\* Electroless nickel plated

### Replacement Parts

No.	Description	Material	Parts no.	
			AS2000	AS3000
3	<b>Valve</b>	NBR, Brass	143022	14283
5	<b>O-ring</b>	NBR	143021	14284
6	<b>Spring</b>	Stainless steel	143023	14282

## Construction: AS4000

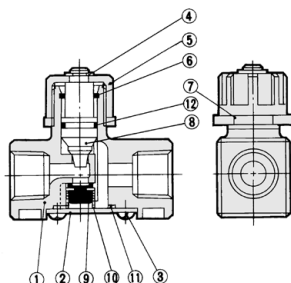

### Component Parts

No.	Description	Material
1	<b>Body</b>	Aluminum alloy
2	<b>Cap</b>	Rolled steel
3	<b>Cross-recessed head cap screw</b>	Steel wire
4	<b>E type snap ring</b>	Stainless steel
5	<b>Handle</b>	Zinc alloy
6	<b>Ring</b>	Steel wire
7	<b>Lock nut</b>	Zinc alloy
8	<b>Needle</b>	Aluminum alloy
12	<b>O-ring</b>	NBR

### Replacement Parts

No.	Description	Material	Parts no.
9	<b>Valve</b>	NBR, Brass	143145
10	<b>Spring</b>	Stainless steel	143146
11	<b>O-ring</b>	NBR	143147

## Construction: AS5000

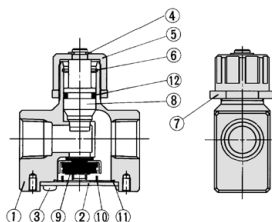

### Component Parts

No.	Description	Material
1	<b>Body</b>	Aluminum alloy
2	<b>Cap</b>	Rolled steel
3	<b>Cross-recessed head cap screw</b>	Steel wire
4	<b>E type snap ring</b>	Stainless steel
5	<b>Handle</b>	Zinc alloy
6	<b>Ring</b>	Stainless steel
7	<b>Lock nut</b>	Zinc alloy
8	<b>Needle</b>	Aluminum alloy
12	<b>O-ring</b>	NBR

### Replacement Parts

No.	Description	Material	Parts no.
9	<b>Valve</b>	NBR, Stainless steel	14143
10	<b>Spring</b>	Stainless steel	14144
11	<b>Seal</b>	NBR	14147

**Dimensions: AS1000-M3**

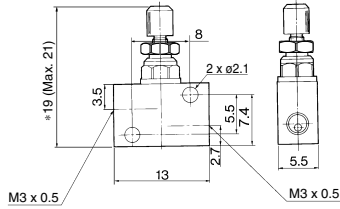

\* Reference dimensions

**Dimensions: AS1000-M5**

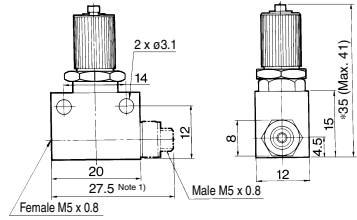

\* Reference dimensions  
Note 1) Dimension for AS1000-M5-N

**Dimensions: AS2000/3000**

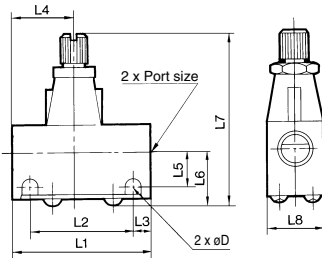

**Dimensions**

Model	Bore size	L1	L2	L3	L4	L5	L6	L7 (1)		L8	D
								Max.	Min.		
AS2000-01	1/8	40	30	5	17	10	15.5	54.5	50	16	4.5
AS2000-02	1/4	40	30	5	23	11.5	17	56	51.5	20	4.5
AS3000-02, 03	1/4, 3/8	56	45.5	5.25	25	13.2	20.6	68	61	26	5.5

Note 1) L7: Reference dimensions

**Dimensions: AS4000**

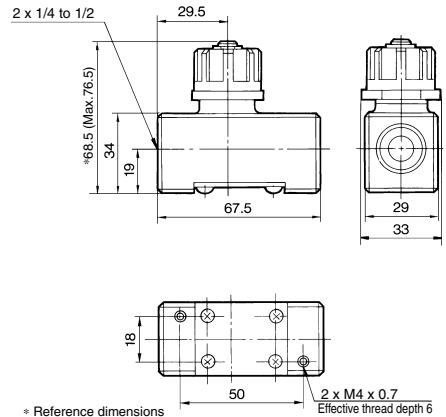

\* Reference dimensions

**Dimensions: AS5000**

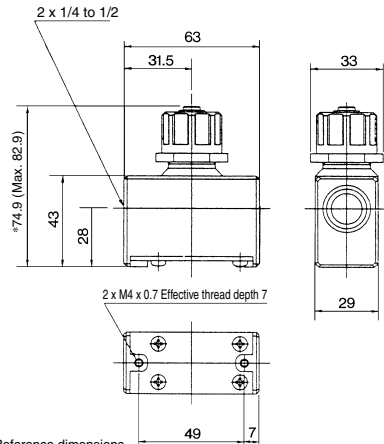

\* Reference dimensions

- AS-F
- TMH
- ASD
- AS
- AS-FE
- KE
- AS-FG
- AS-FP
- AS-FM
- AS-D
- AS-T
- ASP
- ASN
- AQ
- ASV
- AK
- VCHC
- ASR
- ASQ