

Parallel Type Air Gripper: Wide Type

MHL2 Series

ø10, ø16, ø20, ø25, ø32, ø40

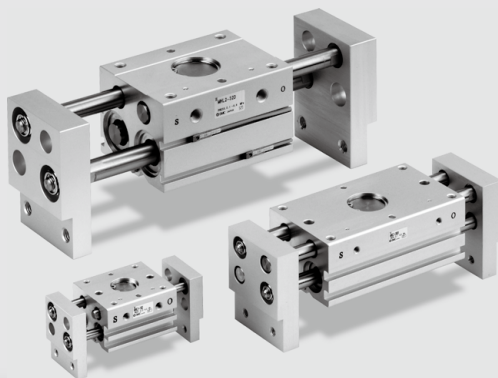

Built-in dust-protection mechanism

A scraper with a dust lip is adopted for all rod rotating parts.

Double-end type oil-impregnated resin bearings with a metal backing are used for all shafts.

Fingers synchronized by a rack and pinion mechanism.

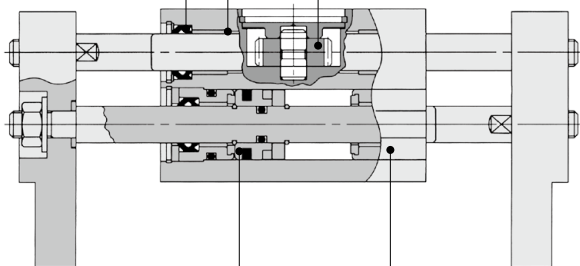

A large amount of gripping force is provided through the use of a double piston mechanism, while maintaining a compact design.

Smaller auto switch mountable

An auto switch can be mounted at 4 locations.

Stroke Variation

Model	Bore size mm			
	10	16	20	25
MHL2-□D	20	30	40	50
MHL2-□D1	40	60	80	100
MHL2-□D2	60	80	100	120

* Values of opening/closing strokes (mm)



MHZ

MHF

MHL

MHR

MHK

MHS

MHC

MHT

MHY

MHW

-X□

MRHQ

MA

D-□

Parallel Type Air Gripper: Wide Type

MHL2 Series

ø10, ø16, ø20, ø25, ø32, ø40

How to Order

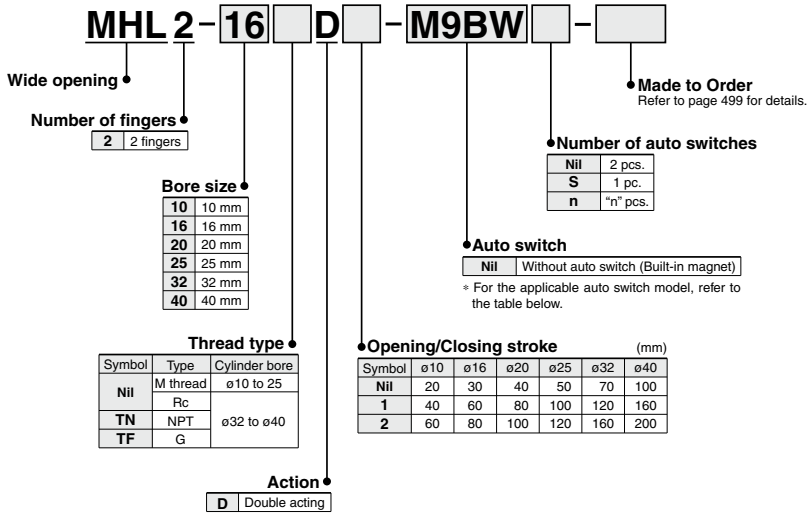

Applicable Auto Switches

Refer to pages 797 to 850 for further information on the auto switches.

Type	Special function	Electrical entry	Indicator light	Wiring (Output)	Load voltage		Auto switch model		Lead wire length (m) *				Pre-wired connector	Applicable load	
					DC	AC	Electrical entry direction		0.5 (Nil)	1 (M)	3 (L)	5 (Z)		IC circuit	Relay, PLC
							Perpendicular	In-line							
Solid state auto switch	—	Grommet	Yes	3-wire (NPN)	5 V, 12 V	—	M9NV	M9N	●	●	●	○	○	IC circuit	Relay, PLC
				3-wire (PNP)			12 V	M9PV	M9P	●	●	●	○	○	
	Diagnosis (2-color indication)			2-wire	5 V, 12 V	—	M9BV	M9B	●	●	●	○	○	—	
				3-wire (NPN)			5 V, 12 V	M9NWV	M9NW	●	●	●	○	○	
	Water resistant (2-color indication)			3-wire (PNP)	12 V	M9PWV	M9PW	●	●	●	○	○	—		
				2-wire	5 V, 12 V	—	M9BWW	M9BW	●	●	●	○	○	—	
	3-wire (NPN)			5 V, 12 V			M9NAV**	M9NA**	○	○	●	○	○	IC circuit	
	3-wire (PNP)			12 V	M9PAV**	M9PA**	○	○	●	○	○	—			
	2-wire			12 V	M9BAV**	M9BA**	○	○	●	○	○	—			

** Water resistant type auto switches can be mounted on the above models, but in such case SMC cannot guarantee water resistance.

* Lead wire length symbols: 0.5 m Nil (Example) M9NW

* Solid state auto switches marked with "○" are produced upon receipt of order.

1 m M (Example) M9NWW

3 m L (Example) M9NWL

5 m Z (Example) M9NZZ

Note 1) When using the 2-color indicator type, please make the setting so that the indicator is lit in red to ensure the detection at the proper position of the air gripper.

Note 2) When ordering the air gripper with the auto switch, the auto switch mounting bracket is included.

When ordering the auto switch separately, the auto switch mounting bracket (BMG2-012) is required.

Long stroke

One unit can handle workpieces with various diameters.

A large amount of gripping force is provided through the use of a double piston mechanism, while maintaining a compact design.

Double-end type oil-impregnated resin bearings with a metal backing are used for all shafts.

Built-in dust-protection mechanism

A high degree of freedom for mounting

Auto switch mountable

Applicable for Clean Series.
Refer to "Pneumatic Clean Series (CAT.E02-23)" catalog for details.



Symbol

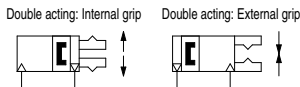

Made to Order
Made to Order: Individual Specifications
(For details, refer to page 512.)

Symbol	Specifications/Description
-X28	With adjuster bolts for adjusting closing width

Made to Order
Made to Order
(Refer to pages 725 to 748 for details.)

Symbol	Specifications/Description
-X4	Heat resistance (100°C)
-X5	Fluororubber seal
-X50	Without magnet
-X53	EPDM seal/Fluorine grease
-X63	Fluorine grease
-X79	Grease for food processing machines/Fluorine grease
-X79A	Grease for food processing machines

Specifications

Bore size (mm)	10	16	20	25	32	40
Fluid	Air					
Action	Double acting					
Operating pressure (MPa)	0.15 to 0.6					
Ambient and fluid temperature	-10 to 60°C					
Repeatability	±0.1					
Lubrication	Not required					
Effective gripping force (N) ^(Note) at 0.5 MPa	14	45	74	131	228	396

(Note) Gripping point = Bore size 10, 16, 20, 25: 40 mm, Bore size 32, 40: 80 mm.

Model/Stroke

Model	Bore size (mm)	Max. operating frequency c.p.m	Opening/Closing stroke (mm) (L2-L1)	Width at closing (mm) (L1)	Width at opening (mm) (L2)	Weight (g)
MHL2-10D	10	60	20	56	76	280
MHL2-10D1		40	40	78	118	345
MHL2-10D2		60	60	96	156	425
MHL2-16D	16	60	30	68	98	585
MHL2-16D1		40	60	110	170	795
MHL2-16D2		80	80	130	210	935
MHL2-20D	20	60	40	82	122	1025
MHL2-20D1		40	80	142	222	1495
MHL2-20D2		100	100	162	262	1690
MHL2-25D	25	60	50	100	150	1690
MHL2-25D1		40	100	182	282	2560
MHL2-25D2		120	120	200	320	2775
MHL2-32D	32	30	70	150	220	2905
MHL2-32D1		20	120	198	318	3820
MHL2-32D2		160	160	242	402	4655
MHL2-40D	40	30	100	188	288	5270
MHL2-40D1		20	160	246	406	6830
MHL2-40D2		200	200	286	486	7905

(Note) The open and close time spans represent the value when the exterior of the workpiece is being held.

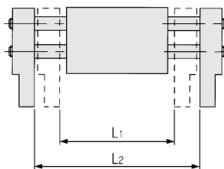

⚠ Precautions

- ⚠ Be sure to read this before handling the products.
- ⚠ Refer to back page 50 for Safety Instructions and pages 366 to 374 for Air Gripper and Auto Switch Precautions.

⚠ Warning

If a workpiece is hooked onto the attachment, make sure that excessive impact will not be created at the start and the end of the movement.
Failure to observe this precaution may result in shifting or dropping the workpiece, which could be dangerous.

MHZ
MHF
MHL
MHR
MHK
MHS
MHC
MHT
MHY
MHW
-X□
MRHQ
MA
D-□

MHL2 Series

Gripping Point

- The workpiece gripping point distance should be within the gripping force ranges given for each pressure in the effective gripping force graphs below.
- If operated with the workpiece gripping point beyond the indicated ranges, the load that will be applied to the fingers or the guide will become excessively unbalanced. As a result, the fingers can become loosened and adversely affect the service life of the unit.

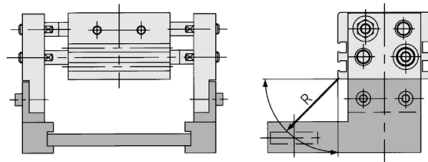

R: Gripping position (mm)

Effective Gripping Force

Indication of effective gripping force

The gripping force shown in the tables represents the gripping force of one finger when all fingers and attachments are in contact with the work.

F = one finger thrust.

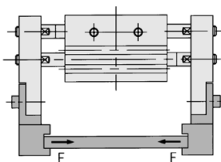

MHL2-10D

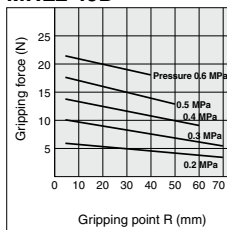

MHL2-10D₂

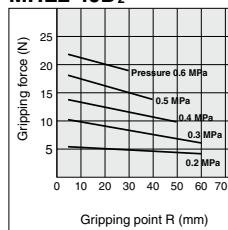

MHL2-16D

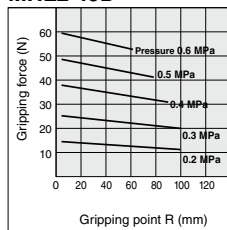

MHL2-16D₂

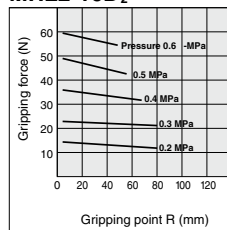

MHL2-20D

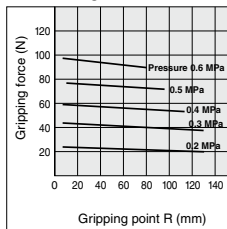

MHL2-20D₂

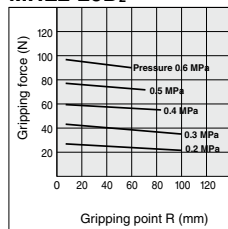

MHL2-25D

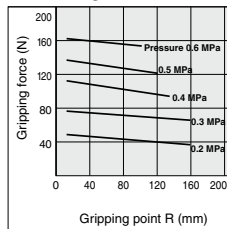

MHL2-25D₂

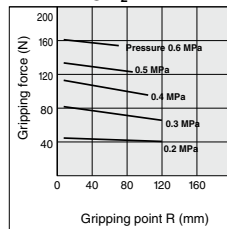

MHL2-32D

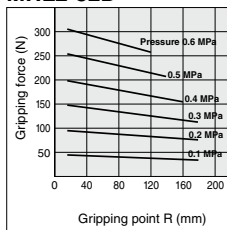

MHL2-32D₂

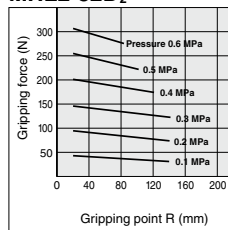

MHL2-40D

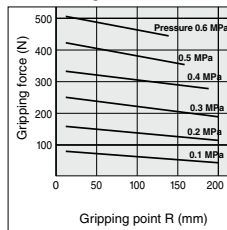

MHL2-40D₂

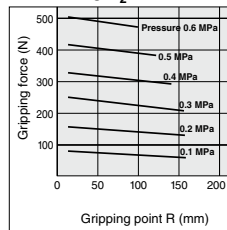

Model Selection Example

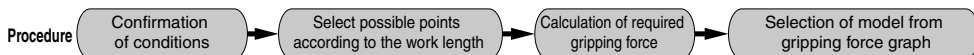

Work form
Diameter x Length
200 mm x 20 mm plate

Work length: From the dimensions of models that have an opening width of 200 mm or more
MHL2-16D2
MHL2-20D1/D2
MHL2-25D1/D2

Work mass: 0.3 kg

Guidelines for the selection of the gripper with respect to component mass

- Although conditions differ according to the workpiece shape and the coefficient of friction between the attachments and the workpiece, select a model that can provide a gripping force of 10 to 20 times the workpiece mass, or more.
- Further allowance should be provided when great acceleration or impact is expected during workpiece transfer.
Example) For setting the gripping force to be at least 20 times the workpiece mass: Required gripping force = $0.3 \text{ kg} \times 20 \times 9.8 \text{ m/s}^2 \approx 60 \text{ N}$

Gripping point R = 70 mm

Operating pressure: 0.5 MPa

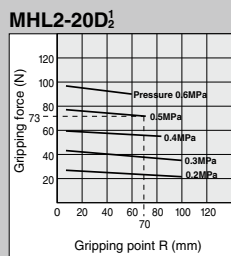

- Selecting the **MHL2-20D₁**
A gripping force of 73 N is obtained from the intersection point of gripping point position R = 70 and a pressure 0.5 MPa.
- The gripping force is 24 times greater than the workpiece mass, and therefore satisfies a gripping force setting value of 20 times or more.

- MHZ
- MHF
- MHL**
- MHR
- MHK
- MHS
- MHC
- MHT
- MHY
- MHW
- X□
- MRHQ
- MA
- D-□

MHL2 Series

Construction

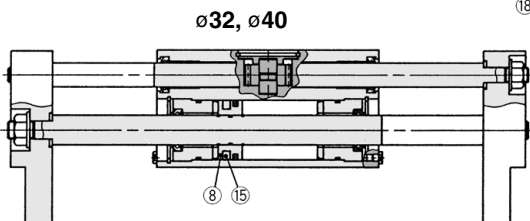
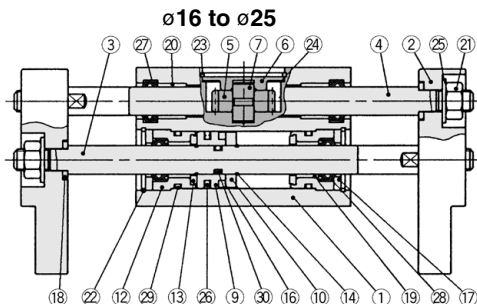
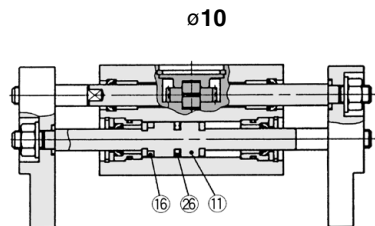

Component Parts

No.	Description	Material	Note
1	Body	Aluminum alloy	Hard anodized
2	Finger	Aluminum alloy	Hard anodized
3	Piston rod	Stainless steel	
4	Rack	Stainless steel	
5	Pinion	Carbon steel	Nitriding
6	Pinion cover	Carbon steel	Electroless nickel plated
7	Pinion axis	Stainless steel	Nitriding
8	Piston	Brass	
9	Piston A	Brass	
10	Piston B	Brass	
11	Piston A	Stainless steel	
12	Rod cover	Aluminum alloy	Chromate treated
13	Bumper	Urethane rubber	
14	Clip	Stainless steel spring wire	
15	Rubber magnet	Synthetic rubber	
16	Magnet	—	Nickel plated

No.	Description	Material	Note
17	Rod seal cover B	Cold rolled steel	Electroless nickel plated
18	Washer	Stainless steel	Nitriding
19	Bearing	Oil containing polyacetal with back metal	
20	Bearing	Oil containing polyacetal with back metal	
21	U nut	Carbon steel	Zinc chromated
22	R-shape retaining ring	Carbon steel	Phosphate coated
23	Type C retaining ring	Carbon steel	Phosphate coated
24	Wave washer	Steel for spring	Phosphate coated
25	Conical spring washer	Carbon steel	Nickel plated
26	Piston seal	NBR	
27	Rod seal	NBR	
28	Rod seal	NBR	
29	Gasket	NBR	
30	Gasket	NBR	

Replacement Parts

Description	MHL2-10□	MHL2-16□	MHL2-20□	MHL2-25□	MHL2-32□	MHL2-40□	Main parts
Seal kit	MHL10-PS	MHL16-PS	MHL20-PS	MHL25-PS	MHL32-PS	MHL40-PS	26/27/28/29/30
Piston assembly	MHL2-□□D	MHL-A1001	MHL-A1601	MHL-A2001	MHL-A2501	MHL-A3201	MHL-A4001
	MHL2-□□D1	MHL-A1002	MHL-A1602	MHL-A2002	MHL-A2502	MHL-A3202	MHL-A4002
	MHL2-□□D2	MHL-A1003	MHL-A1603	MHL-A2003	MHL-A2503	MHL-A3203	MHL-A4003
Rack	MHL2-□□D	MHL-A1004	MHL-A1604	MHL-A2004	MHL-A2504	MHL-A3204	MHL-A4004
	MHL2-□□D1	MHL-A1005	MHL-A1605	MHL-A2005	MHL-A2505	MHL-A3205	MHL-A4005
	MHL2-□□D2	MHL-A1006	MHL-A1606	MHL-A2006	MHL-A2506	MHL-A3206	MHL-A4006
Rod Cover assembly	MHL-A1007	MHL-A1607	MHL-A2007	MHL-A2507	MHL-A3207	MHL-A4007	□□10~12/17/19/22/25 29 □□16 to 40~12/13/17/19/22/25/29
Finger assembly	MHL-A1008	MHL-A1608	MHL-A2008	MHL-A2508	MHL-A3208	MHL-A4008	2/18/21/25
Pinion assembly	MHL-A1009	MHL-A1609	MHL-A2009	MHL-A2509	MHL-A3209	MHL-A4009	5/6/7/23/24
Nut set	MHL-A1017	MHL-A1617	MHL-A2017	MHL-A2517	MHL-A3217	MHL-A4017	18/21/25
U nut assembly	MHL-A1017A	MHL-A1617A	MHL-A2017A	MHL-A2517A	MHL-A3217A	MHL-A4017A	21/25

* Order one finger assembly, pinion assembly, nut set and U nut assembly per unit.

* For piston assembly and rack, order 2 pieces per unit.

* For rod cover assembly, order 4 pieces per unit.

Replacement part: grease pack part no.

MHL2-□□D (ø10 to 20)	GR-S-010 (10 g)
MHL2-□□D (ø25, 32)	GR-S-010 (10 g)
MHL2-□□D (ø40)	GR-S-020 (20 g)
MHL2-□□D1 (ø10, 16)	GR-S-010 (10 g)
MHL2-□□D1 (ø20, 25)	GR-S-010 (10 g)
MHL2-□□D1 (ø32, 40)	GR-S-020 (20 g)
MHL2-□□D2 (ø10, 16)	GR-S-010 (10 g)
MHL2-□□D2 (ø20, 25)	GR-S-010 (10 g)
MHL2-□□D2 (ø32, 40)	GR-S-010 (10 g), GR-S-020 (20 g) (1 pack each)

Dimensions

MHL2-10D □

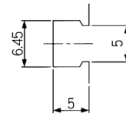
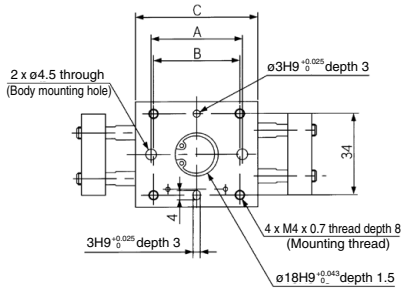
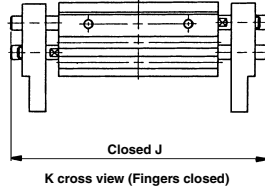
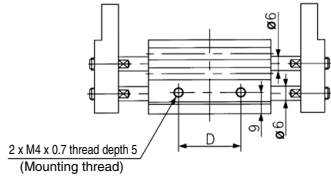

* Dimensions of auto switch mounting groove (Enlarged view)

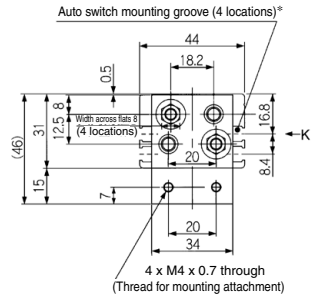
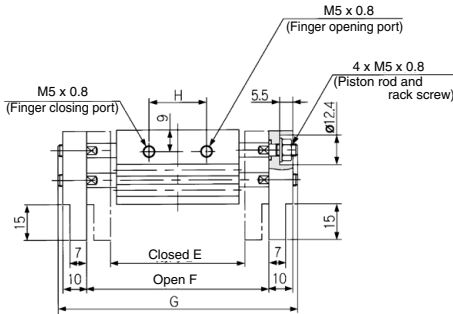

Model	A	B	C	D	E	F	G	H	J
MHL2-10D	38	36	51	26	56	76	100	24	80
MHL2-10D1	54	52	67	42	78	118	142	39	108
MHL2-10D2	72	70	85	60	96	156	180	57	146

Note 1) J dimension is at fully closed.

Note 2) D1 is different from D2 at finger closed because shaft is ejected from finger end. J dimension is different from the value which is subtracted stroke from G dimension.

MHZ

MHF

MHL

MHR

MHK

MHS

MHC

MHT

MHY

MHW

-X □

MRHQ

MA

D- □

Dimensions

MHL2-32D □

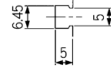
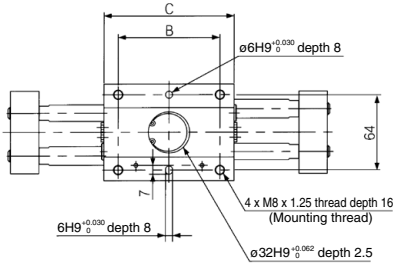
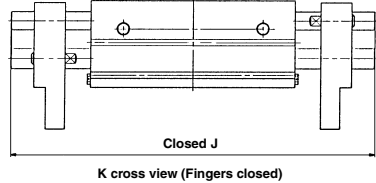
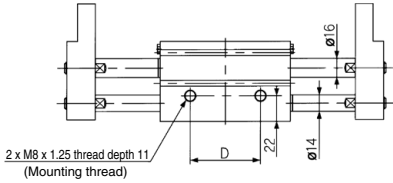

* Dimensions of auto switch mounting groove (Enlarged view)

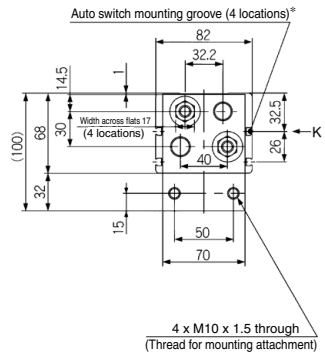
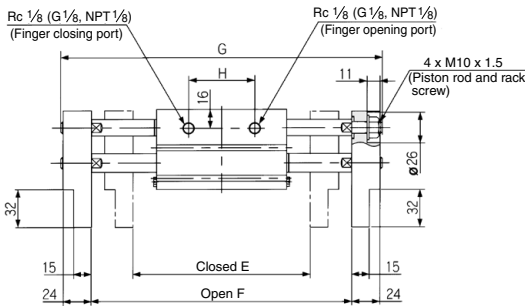

(mm)

Model	B	C	D	E	F	G	H	J
MHL2-32D	86	110	60	150	220	272	56	202
MHL2-32D1	134	158	108	198	318	370	104	282
MHL2-32D2	178	202	152	242	402	454	148	366

Note 1) J dimension is at fully closed.

Note 2) D1 is different from D2 at finger closed because shaft is ejected from finger end. J dimension is different from the value which is subtracted stroke from G dimension.

- MHZ
- MHF
- MHL**
- MHR
- MHK
- MHS
- MHC
- MHT
- MHY
- MHW
- X □
- MRHQ
- MA
- D- □

MHL2 Series

Dimensions

MHL2-40D

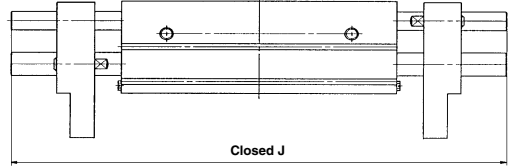
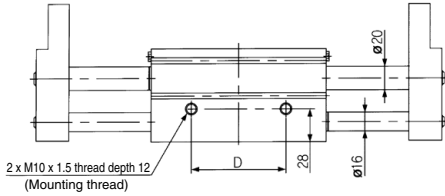

K cross view (Fingers closed)

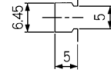
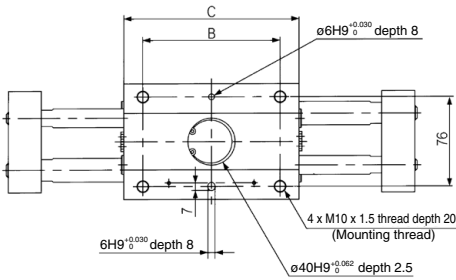

* Dimensions of auto switch mounting groove (Enlarged view)

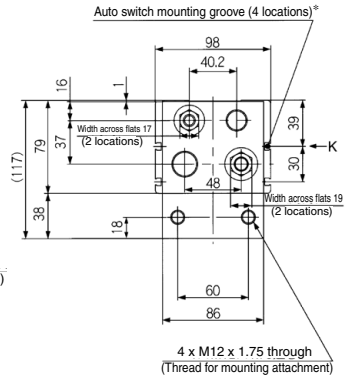
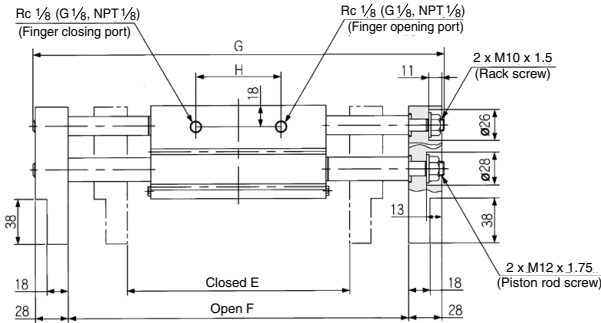

(mm)

Model	B	C	D	E	F	G	H	J
MHL2-40D	116	148	80	188	288	348	72	252
MHL2-40D1	174	206	138	246	406	466	130	370
MHL2-40D2	214	246	178	286	486	546	170	450

Note 1) J dimension is at fully closed.

Note 2) D1 is different from D2 at finger closed because shaft is ejected from finger end. J dimension is different from the value which is subtracted stroke from G dimension.

MHL2 Series Auto Switch Installation Examples and Mounting Positions

Various auto switch applications are possible through different combinations of auto switch quantities and detecting positions.

1) Detection when Gripping Exterior of Workpiece

Detection example		1. Confirmation of fingers in reset position	2. Confirmation of workpiece held	3. Confirmation of workpiece released	
Position to be detected		Position of fingers fully opened	Position when gripping a workpiece	Position of fingers fully closed	
Operation of auto switch		Auto switch turned ON when fingers return. (Light ON)	Auto switch turned ON when gripping a workpiece. (Light ON)	When a workpiece is not held (Abnormal operation): Auto switch to turn ON (Light ON)	
Detection combinations	One auto switch * One position, any of ①, ② and ③ can be detected.	●	●	●	
	Two auto switches * Two positions of ①, ② and ③ can be detected.	A	●	—	
		B	—	●	
Pattern	C	●	—	●	
How to determine auto switch installation position		Step 1) Fully open the fingers.	Step 1) Position fingers for gripping a workpiece.	Step 1) Fully close the fingers.	
At no pressure or low pressure, connect the auto switch to a power supply, and follow the directions.		Step 2) Insert the auto switch into the auto switch installation groove in the direction shown in the following drawing.			
		Step 3) Slide the auto switch in the direction of the arrow until the indicator light illuminates.	Step 3) Slide the auto switch in the direction of the arrow until the indicator light illuminates. Move the switch further 0.3 to 0.5 mm in the direction of the arrow and fasten it.		
		Step 4) Slide the auto switch further in the direction of the arrow until the indicator light goes out.	Position where light turns ON		
		Step 5) Move the auto switch in the opposite direction and fasten it at a position 0.3 to 0.5 mm beyond the position where the indicator light illuminates.	Position to be secured		
		Position where light turns ON	Position to be secured		







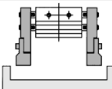
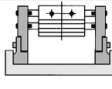
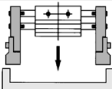

Note 1) It is recommended that gripping of a workpiece be performed close to the center of the finger stroke.

Note 2) When holding a workpiece close at the end of open/close stroke of fingers, detecting performance of the combinations listed in the above table may be limited, depending on the hysteresis of an auto switch, etc.

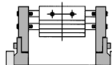
MHL2 Series Auto Switch Installation Examples and Mounting Positions

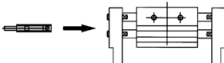
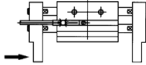
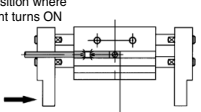
Various auto switch applications are possible through different combinations of auto switch quantities and detecting positions.

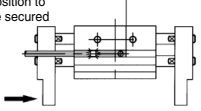
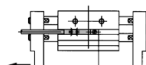
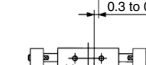
2) Detection when Gripping Interior of Workpiece

Detection example		1. Confirmation of fingers in reset position	2. Confirmation of workpiece held	3. Confirmation of workpiece released
Position to be detected				
Operation of auto switch		Auto switch turned ON when fingers return. (Light ON)	Auto switch turned ON when gripping a workpiece. (Light ON)	When a workpiece is not held (Abnormal operation): Auto switch to turn ON (Light ON)
Detection combinations	One auto switch * One position, any of ①, ② and ③ can be detected.	●	●	●
	Two auto switches * Two positions of ①, ② and ③ can be detected.	A	●	—
		B	—	●
C	●	—	●	
How to determine auto switch installation position		Step 1) Fully close the fingers. 	Step 1) Position fingers for gripping a workpiece. 	Step 1) Fully open the fingers. 
At no pressure or low pressure, connect the auto switch to a power supply, and follow the directions.		Step 2) Insert the auto switch into the auto switch installation groove in the direction shown in the following drawing. 		
Step 3) Move the auto switch in the direction of the arrow until the light illuminates and fasten it at a position 0.3 to 0.5 mm in the direction of the arrow beyond the position where the indicator light illuminates.		Step 3) Slide the auto switch in the direction of the arrow until the indicator light illuminates. 		
Position where light turns ON 		Step 4) Slide the auto switch a further distance in the direction of the arrow until the indicator light goes out. 		
Position to be secured 		Step 5) Move the auto switch in the opposite direction and fasten it at a position 0.3 to 0.5 mm beyond the position where the indicator light illuminates. 		
		Position where light turns ON 		
		Position to be secured 		

Note 1) It is recommended that gripping of a workpiece be performed close to the center of the finger stroke.

Note 2) When holding a workpiece close at the end of open/close stroke of fingers, detecting performance of the combinations listed in the above table may be limited, depending on the hysteresis of an auto switch, etc.

Auto Switch Mounting

- (1) To set the auto switch, insert the auto switch into the installation groove of the cylinder as shown below and set it roughly.
- (2) Insert the auto switch into the auto switch bracket installation groove.
- (3) After confirming the detecting position, tighten the set screws (M2.5) attached to the auto switch and set it.
- (4) Be sure to change the detecting position in the state of (2).

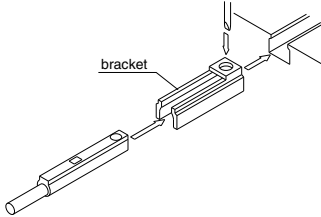

Note) Use a watchmaker's screwdriver with a grip diameter of 5 to 6 mm to tighten the set screws (M2.5).
The tightening torque should be 0.05 to 0.1 N·m.
As a rule, it should be turned about 90° beyond the point at which tightening can be felt.

Auto Switch Mounting Bracket: Part No.

Auto switch part no.	Auto switch mounting bracket part no.
D-M9□(V) D-M9□W(V) D-M9□A(V)	BMG2-012

Auto Switch Mounting Brackets: Precautions

When auto switch is set on the mounting side as shown below, allow at least 2 mm runoff space on mounting plate since the auto switch is protruded from the gripper edge.

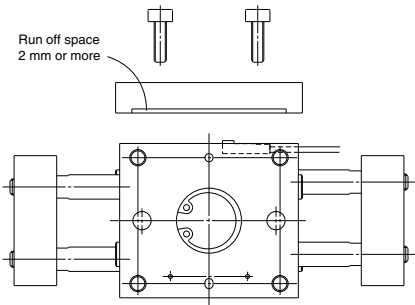

Auto Switch Hysteresis

The auto switch hysteresis is shown in the table below. Please refer to the table as a guide when setting auto switch positions.

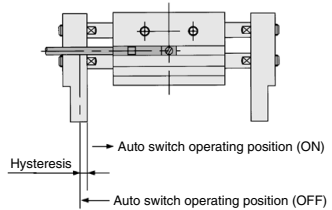

(mm)

Auto switch part no.	D-Y59□/Y69□/Y7P/Y7PV D-Y7□W/Y7□WV	D-M9□(V) D-M9□W(V) D-M9□A(V)
MHL2-10D□	0.8	0.3
MHL2-16D□	0.5	0.4
MHL2-20D□	0.5	0.7
MHL2-25D□	0.5	0.6
MHL2-32D□	0.5	0.6
MHL2-40D□	0.5	0.9

MHZ

MHF

MHL

MHR

MHK

MHS

MHC

MHT

MHY

MHW

-X□

MRHQ

MA

D-□

1 With An Adjuster for Closing Stroke Adjustment

Symbol
-X28

Finger closing stroke can be fine-tuned by an adjustment bolt.

How to Order

Standard part number **-X28**

With An Adjuster for Closing Stroke Adjustment

Specifications

Bore size (mm)	10, 16, 20, 25, 32
Adjustment range/ Adjustment bolt position	Refer to the dimensions and figures below.
Specifications/dimensions other than the above	Same as the standard type

Note) Please contact SMC for the MHL2 series ø40.

Dimensions (Dimensions other than specified below are the same as the standard type.)

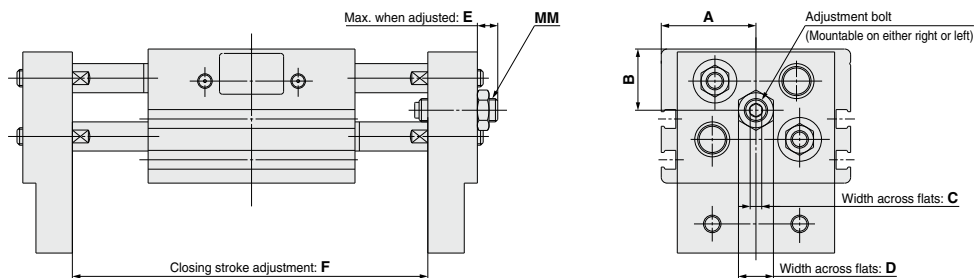

Model	A	B	C	D	E	F	MM
MHL2-10D-X28					4	2	M5 x 0.8
MHL2-10D1-X28	22	15.5	2.5	7	11	16	
MHL2-10D2-X28					11	16	
MHL2-16D-X28	27.5	18.5	3	8	9.5	9	M6 x 1
MHL2-16D1-X28					13.5	20	
MHL2-16D2-X28					13.5	20	
MHL2-20D-X28	32.5	21	4	12	7.5	7	M8 x 1
MHL2-20D1-X28					8.5	9	
MHL2-20D2-X28					8.5	9	
MHL2-25D-X28	38	26	5	14	7.5	7	M10 x 1
MHL2-25D1-X28					15	18	
MHL2-25D2-X28					15	18	
MHL2-32D-X28	41	32	6	19	32.5	51	M12 x 1.75
MHL2-32D1-X28					32.5		
MHL2-32D2-X28					32.5		



MHL2 Series Specific Product Precautions

Be sure to read this before handling the products.

Mounting Air Grippers/MHL2 Series

Possible to mount from 2 directions.

Axial Mounting

●Body tapped

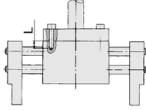

Model	Applicable bolts	Max. tightening torque (N·m)	Max. screw-in depth (Lmm)
MHL2-10D□	M4 x 0.7	2.1	8
MHL2-16D□	M5 x 0.8	4.3	10
MHL2-20D□	M6 x 1	7.3	12
MHL2-25D□	M8 x 1.25	17.7	16
MHL2-32D□	M8 x 1.25	18	16
MHL2-40D□	M10 x 1.5	36	20

●Body ø10 to ø25

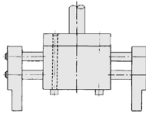

Model	Applicable bolts	Max. tightening torque (N·m)
MHL2-10D□	M4 x 0.7	2.1
MHL2-16D□	M5 x 0.8	4.3
MHL2-20D□	M6 x 1	7.3
MHL2-25D□	M8 x 1.25	17.7

Lateral mounting

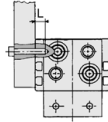

Model	Applicable bolts	Max. tightening torque (N·m)	Max. screw-in depth (Lmm)
MHL2-10D□	M4 x 0.7	1.4	5
MHL2-16D□	M5 x 0.8	2.8	7
MHL2-20D□	M6 x 1	4.8	7
MHL2-25D□	M8 x 1.25	12.0	7
MHL2-32D□	M8 x 1.25	12.0	11
MHL2-40D□	M10 x 1.5	24.0	12

How to Mount the Attachment to the Finger

- (1) Make sure that the piston rod is retracted so as not to apply undue strain on the piston rod while an attachment is being mounted to the finger.
- (2) Do not scratch or dent the sliding portion of the piston rod. Damage to the bearings or seals may cause air leaks or faulty operation.
- (3) Refer to the table below for the proper tightening torque on the bolt used for securing the attachment to the finger.

Model	Applicable bolts	Max. tightening torque (N·m)
MHL2-10D□	M4 x 0.7	1.4
MHL2-16D□	M5 x 0.8	2.8
MHL2-20D□	M6 x 1	4.8
MHL2-25D□	M8 x 1.25	12.0
MHL2-32D□	M10 x 1.5	24.0
MHL2-40D□	M12 x 1.75	42.2

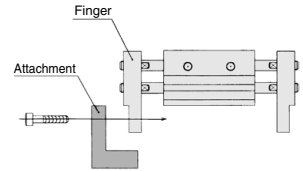

MHZ

MHF

MHL

MHR

MHK

MHS

MHC

MHT

MHY

MHW

-X□

MRHQ

MA

D-□