

A Wide Range of Basic Output Units for High Speed Output and Different Applications

- These Output Units receive the results of output instructions from the CPU Unit and perform ON/OFF control for external devices.
- High-speed Output models CJ1W-OD213 and CJ1W-OD234 can help to increase system throughput.



CJ1W-OD213



CJ1W-OD234

Features

- High-speed output models are available, meeting versatile applications.
ON Response Time: 15 μ s, OFF Response Time: 80 μ s
- Output Units are available with any of three output types: relay contact outputs, triac outputs, or transistor outputs.
- For transistor outputs, select from sinking outputs or sourcing outputs.
- Output Units with load short-circuit protection are also available. *1
- Select the best interface for each application: Fujitsu connectors or MIL connectors. *2
- A wide variety of Connector-Terminal Block Conversion Units are available to allow you to easily wire external output devices.

*1. The following Units have load short-circuit protection: CJ1W-OC202, CJ1W-OD204, CJ1W-OD212, and CJ1W-OD232.





*2. Available for models with 32 outputs or 64 outputs

Ordering Information

International Standards

- The standards are abbreviated as follows: U: UL, U1: UL (Class I Division 2 Products for Hazardous Locations), C: CSA, UC: cULus, UC1: cULus (Class I Division 2 Products for Hazardous Locations), CU: cUL, N: NK, L: Lloyd, and CE: EC Directives.
- Contact your OMRON representative for further details and applicable conditions for these standards.

Output Units

Unit type	Product name	Specifications					No. of words allocated	Current consumption (A)		Model	Standards	
		Output type	I/O points	Maximum switching capacity	Commons	External connection		5 V	24 V			
CJ1 Basic I/O Units	Relay Contact Output Units 	-	8 outputs	250 VAC/24 VDC, 2 A	Independent contacts	Removable terminal block	1 words	0.09	0.048 max.	CJ1W-OC201	UC1, N, L, CE	
		-	16 outputs	250 VAC/24 VDC, 2 A	16 points, 1 common	Removable terminal block	1 words	0.11	0.096 max.	CJ1W-OC211		
	Triac Output Unit 	-	8 outputs	250 VAC, 0.6 A	8 points, 1 common	Removable terminal block	1 words	0.22	-	CJ1W-OA201		
	Transistor Output Units   	Sinking	8 outputs	12 to 24 VDC, 2 A	4 points, 1 common	Removable terminal block	1 words	0.09	-	CJ1W-OD201		
		Sinking	8 outputs	12 to 24 VDC, 0.5 A	8 points, 1 common	Removable terminal block	1 words	0.10	-	CJ1W-OD203		
		Sinking	16 outputs	12 to 24 VDC, 0.5 A	16 points, 1 common	Removable terminal block	1 words	0.10	-	CJ1W-OD211		
		Sinking	16 outputs (High speed)	24 VDC, 0.5 A	16 points, 1 common	Removable terminal block	1 words	0.15	-	CJ1W-OD213		N, L, CE
		Sinking	32 outputs	12 to 24 VDC, 0.5 A	16 points, 1 common	Fujitsu connector	2 words	0.14	-	CJ1W-OD231		UC1, N, L, CE
		Sinking	32 outputs	12 to 24 VDC, 0.5 A	16 points, 1 common	MIL connector	2 words	0.14	-	CJ1W-OD233		
		Sinking	32 outputs (High speed)	24 VDC, 0.5 A	16 points, 1 common	MIL connector	2 words	0.22	-	CJ1W-OD234		N, L, CE
		Sinking	64 outputs	12 to 24 VDC, 0.3 A	16 points, 1 common	Fujitsu connector	4 words	0.17	-	CJ1W-OD261		UC1, N, L, CE
		Sinking	64 outputs	12 to 24 VDC, 0.3 A	16 points, 1 common	MIL connector	4 words	0.17	-	CJ1W-OD263		
		Sourcing	8 outputs	24 VDC, 2 A Short-circuit protection	4 points, 1 common	Removable terminal block	1 words	0.11	-	CJ1W-OD202		
		Sourcing	8 outputs	24 VDC, 0.5 A Short-circuit protection	8 points, 1 common	Removable terminal block	1 words	0.10	-	CJ1W-OD204		
		Sourcing	16 outputs	24 VDC, 0.5 A Short-circuit protection	16 points, 1 common	Removable terminal block	1 words	0.10	-	CJ1W-OD212		
Sourcing	32 outputs	24 VDC, 0.5 A Short-circuit protection	16 points, 1 common	MIL connector	2 words	0.15	-	CJ1W-OD232				
Sourcing	64 outputs	12 to 24 VDC, 0.3 A	16 points, 1 common	MIL connector	4 words	0.17	-	CJ1W-OD262				

Accessories

Connectors are not included for models with connectors. Either use one of the applicable connector listed below or use an applicable Connector-Terminal Block Conversion Unit or I/O Relay Terminal. For details on wiring methods, refer to *External Interface*.

Applicable Connectors

Fujitsu Connectors for 32-input, 32-output, 64-input, 64-output, 32-input/32-output, and 16-input/16-output Units



Name	Connection	Remarks	Applicable Units	Model	Standards	
40-pin Connectors	Soldered	FCN-361J040-AU FCN-360C040-J2	Connector Connector Cover	Fujitsu Connectors: CJ1W-ID231(32 inputs): 1 per Unit CJ1W-ID261 (64 inputs): 2 per Unit CJ1W-OD231 (32 outputs): 1 per Unit CJ1W-OD261 (64 outputs): 2 per Unit CJ1W-MD261 (32 inputs, 32 outputs): 2 per Unit	C500-CE404	-
	Crimped	FCN-363J040 FCN-363J-AU FCN-360C040-J2	Housing Contact Connector Cover		C500-CE405	
	Pressure welded	FCN-367J040-AU/F			C500-CE403	
24-pin Connectors	Soldered	FCN-361J024-AU FCN-360C024-J2	Connector Connector Cover	Fujitsu Connectors: CJ1W-MD231 (16 inputs, 16 outputs): 2 per Unit	C500-CE241	-
	Crimped	FCN-363J024 FCN-363J-AU FCN-360C024-J2	Socket Contact Connector Cover		C500-CE242	
	Pressure welded	FCN-367J024-AU/F			C500-CE243	

MIL Connectors for 32-input, 32-output, 64-input, 64-output, 32-input/32-output, and 16-input/16-output Units

Name	Connection	Remarks	Applicable Units	Model	Standards
40-pin Connectors	Pressure welded	FRC5-AO40-3TOS	MIL Connectors: CJ1W-ID232/233 (32 inputs): 1 per Unit CJ1W-OD232/233/234 (32 outputs):1 per Unit CJ1W-ID262 (64 inputs): 2 per Unit CJ1W-OD262/263 (64 outputs): 2 per Unit CJ1W-MD263/563 (32 inputs, 32 outputs): 2 per Unit	XG4M-4030-T	-
	Crimped	-		XG5N-401*	
20-pin Connectors	Pressure welded	FRC5-AO20-3TOS	MIL Connectors: CJ1W-MD232/233 (16 inputs, 16 outputs): 2 per Unit	XG4M-2030-T	-
	Crimped	-		XG5N-201*	

* Crimp Contacts are also required. Refer to page 31 for details.

Applicable Connector-Terminal Block Conversion Units

Type	Series	Number of poles	Wiring method	Terminal type	Size			Mounting		Common terminals	Bleeder resistance	Indicators	I/O Units	Model *	Standards
					Depth (mm)	Height (mm)	Width (mm)	DIN Track	Screws						
PLCs	XW2R	34	Phillips screw	M3	50	48.05	130.7		No	No	No	No	CJ1W-OD231 CJ1W-OD261	XW2R-J34GD-C3	-
													CJ1W-OD232 CJ1W-OD233 CJ1W-OD234 CJ1W-OD262 CJ1W-OD263		
			Slotted screw (rise up)	M3 (European type)	50	44.81	98.5						CJ1W-OD231 CJ1W-OD261	XW2R-E34GD-C3	
													CJ1W-OD232 CJ1W-OD233 CJ1W-OD234 CJ1W-OD262 CJ1W-OD263	XW2R-E34GD-C4	
			Push-in spring	Clamp	50	44.81	98.5						CJ1W-OD231 CJ1W-OD261	XW2R-P34GD-C3	
													CJ1W-OD232 CJ1W-OD233 CJ1W-OD234 CJ1W-OD262 CJ1W-OD263	XW2R-P34GD-C4	



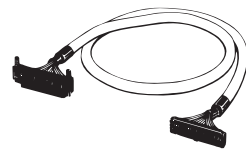
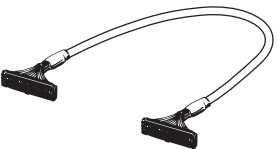

Note: For the combination of Output Units with Connector-Terminal Block Conversion Units, refer to 2. *Connecting Connector-Terminal Block Conversion Units.*

* Representative models only. For details, refer to the XW2R series catalog (Cat. No. G077).

Connecting Cables for Connector-Terminal Block Conversion Units

Appearance	Connectors	Cable length [m]	Model
 XW2Z-□□□B	One 40-pin Fujitsu Connector to One 40-pin MIL Connector	0.5	XW2Z-050B
		1	XW2Z-100B
		1.5	XW2Z-150B
		2	XW2Z-200B
		3	XW2Z-300B
		5	XW2Z-500B
 XW2Z-□□□K	One 40-pin MIL Connector to One 40-pin MIL Connector	0.5	XW2Z-C50K
		1	XW2Z-100K
		1.5	XW2Z-150K
		2	XW2Z-200K
		3	XW2Z-300K
		5	XW2Z-500K

Applicable I/O Relay Terminals

Type	Series	Specifications					Size (horizontal mounting)			Mounting		Model	Standards									
		Classification	Polarity	Number of points	Rated ON current at contacts	Rated voltage	Horizontal (mm)	Vertical (mm)	Height (mm)	DIN Track	Screws											
Push-In Plus terminal block		Inputs	DC inputs	NPN	16 (SPSTNO × 16)	50 mA	24 VDC	143	90	56	Yes	Yes	G70V-SID16P *4	UC, CE (TUV certified)								
				PNP									G70V-SID16P-1 *4									
				NPN									G70V-SID16P-C16 *5									
				PNP									G70V-SID16P-1-C16 *5									
		Outputs	Relay outputs	NPN	16 (SPDT × 16)	6 A/point, 10 A/ common	24 VDC	143	90	56	Yes	Yes	G70V-SOC16P *4									
				PNP									G70V-SOC16P-1 *4									
				NPN									G70V-SOC16P-C4 *6									
				PNP									G70V-SOC16P-1-C4 *6									
Standard		Inputs	AC inputs	NPN	16 (SPSTNO × 16)	1 A	100/(110) VAC	182	85	68	Yes	No	G7TC-IA16 AC100/110	U, C								
							200/(220) VAC						G7TC-IA16 AC200/220									
			DC inputs				12 VDC						G7TC-ID16 DC12									
							24 VDC						G7TC-ID16 DC24									
		Outputs	Relay outputs	NPN	8 (SPSTNO × 8)	5 A	12 VDC	182	102	85	68	Yes	No		G7TC-OC08 DC12							
					16 (SPSTNO × 16)		24 VDC								G7TC-OC08 DC24							
							PNP								12 VDC	G7TC-OC16 DC12						
					16 (SPSTNO × 16)										24 VDC	G7TC-OC16 DC24						
				12 VDC	16 (SPSTNO × 16)	PNP	16 (SPSTNO × 16)	5 A	12 VDC	182	102	85	68		Yes	No	G7TC-OC16-1 DC12					
									24 VDC								G7TC-OC16-1 DC24					
									12 VDC								G7TC-OC16-1 DC12					
									24 VDC								G7TC-OC16-1 DC24					
High-capacity socket		Inputs	Relay inputs	NPN/ PNP	16 (SPDT × 16 possible with G2R Relays)	100 mA	110 VDC max., 240 VAC max. *2	234	75	64	Yes	No	G70A-ZOC16-5	U, C, CE (VDE certified)								
							Outputs						Relay outputs		NPN	24 VDC	G70A-ZOC16-3					
		PNP	G70A-ZOC16-4																			
			Space-saving	Vertical type G70D-V		Relay outputs	NPN						16 (SPSTNO × 16)		5 A or 3 A *3	24 VDC	135	46	81	Yes	Yes	G70D-VSOC16
MOSFET relay outputs	0.3 A	G70D-VFOM16																				
	Flat type G70D	Relay outputs			NPN	8 (SPSTNO × 8)		5 A	156	93	44	Yes		Yes	G70D-SOC08							-
16 (SPSTNO × 16)						3 A		G70D-SOC16														
				PNP	16 (SPSTNO × 16)	3 A	G70D-SOC16-1															
MOSFET relay outputs					NPN	16 (SPSTNO × 16)	0.3 A	24 VDC					156		93	44	Yes	Yes	G70D-FOM16			
	PNP	G70D-FOM16-1 *7																				
High-capacity, space-saving		Outputs		Relay outputs	NPN	8 (SPSTNO × 8)	10 A	24 VDC	136	93	55	Yes	Yes	G70R-SOC08 *7	-							

*1. G70A is a I/O terminal socket product. Relay is not provided with the socket. Be sure to order a relay, timer separately.

*2. Each relay to be mounted must incorporate a coil that has proper specifications within the maximum rated voltage range.

*3. Eight or fewer points ON: 5 A, Nine or more points ON: 3 A.

*4. Internal common at terminal block: No internal connections

*5. Internal common at terminal block: Internal IO common 16 points internally connected

*6. Internal common at terminal block: Every 4 points internally connected at terminal block middle row.

*7. Product no longer available to order.

Note: 1. For the combination of Input Units with I/O Relay Terminal and Connecting Cables, refer to 3. *Connecting I/O Relay Terminals.*

2. Please refer to each Datasheet about details.

3. When the G7TC is used with an AC rated voltage, three rated currents can be used. If a coil voltage of 110 or 220 VAC is used, 50 Hz cannot be used.

Specifications

CJ1W-OC201 Contact Output Unit (Independent Relays, 8 Points)

Name	8-point Contact Output Unit with Terminal Block (Independent Relays)
Model	CJ1W-OC201
Max. Switching Capacity	2 A 250 VAC ($\cos\phi = 1$), 2 A 250 VAC ($\cos\phi = 0.4$), 2 A 24 VDC (16 A/Unit)
Min. Switching Capacity	1 mA 5 VDC
Relays	NY-24W-K-IE (Fujitsu Takamizawa Components, Ltd.), Cannot be replaced.
Service Life of Relay	Electrical: 150,000 operations (24 VDC, resistive load)/100,000 operations (240 VAC, $\cos\phi = 0.4$, inductive load) Mechanical: 20,000,000 operations Service life will vary depending on the connected load.
ON Response Time	15 ms max.
OFF Response Time	15 ms max.
Number of Circuits	8 independent contacts
Insulation Resistance	20 M Ω between external terminals and the GR terminal (500 VDC)
Dielectric Strength	2,000 VAC between the external terminals and the GR terminal for 1 minute at a leakage current of 10 mA max.
Internal Current Consumption	90 mA 5 VDC max. 48 mA 24 VDC max. (6 mA \times No. of ON points)
Weight	140 g max.

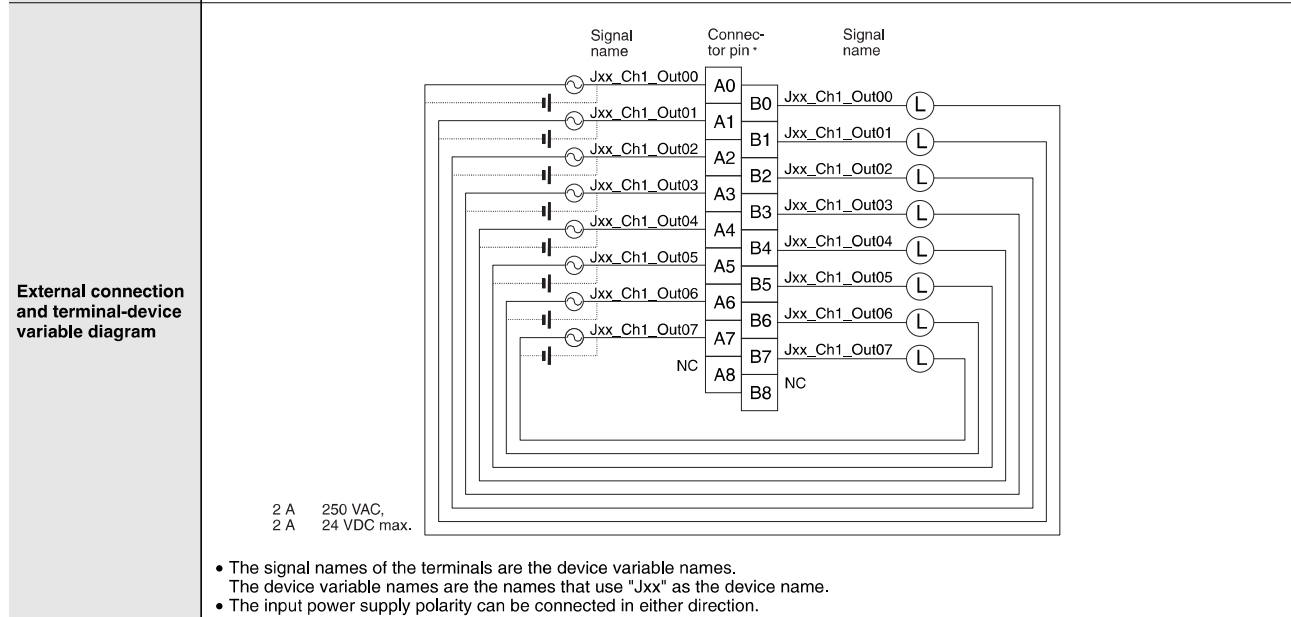
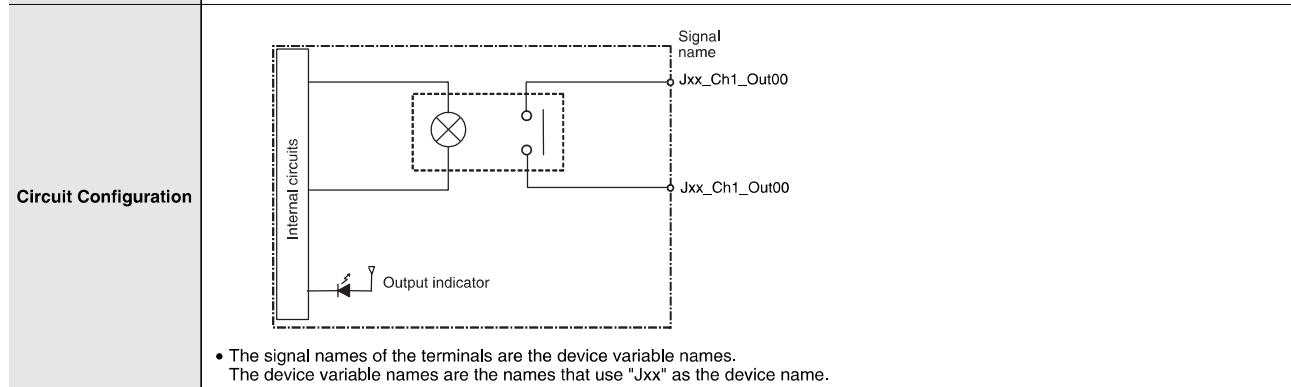

* Terminal numbers A0 to A8 and B0 to B8 are used in the external connection and terminal-device variable diagrams. They are not printed on the Units.

Note: Although 16 I/O bits (1 word) are allocated, only 8 of these can be used for external I/O.

CJ1W-OC211 Contact Output Unit (16 Points)

Name	16-point Contact Output Unit with Terminal Block
Model	CJ1W-OC211
Max. Switching Capacity	2 A 250 VAC ($\cos\phi = 1$), 2 A 250 VAC ($\cos\phi = 0.4$), 2 A 24 VDC (8 A/Unit)
Min. Switching Capacity	1 mA 5 VDC
Relays	NY-24W-K-IE (Fujitsu Takamizawa Components, Ltd.), Cannot be replaced.
Service Life of Relay	Electrical: 150,000 operations (24 VDC, resistive load)/ 100,000 operations (250 VAC, $\cos\phi = 0.4$, inductive load) Mechanical: 20,000,000 operations Service life will vary depending on the connected load.
ON Response Time	15 ms max.
OFF Response Time	15 ms max.
Number of Circuits	16 points/common, 1 circuit
Insulation Resistance	20 M Ω between external terminals and the GR terminal (500 VDC)
Dielectric Strength	2,000 VAC between the external terminals and the GR terminal for 1 minute at a leakage current of 10 mA max.
Internal Current Consumption	110 mA 5 VDC max. 96 mA 24 VDC max. (6 mA \times No. of ON points)
Weight	170 g max.

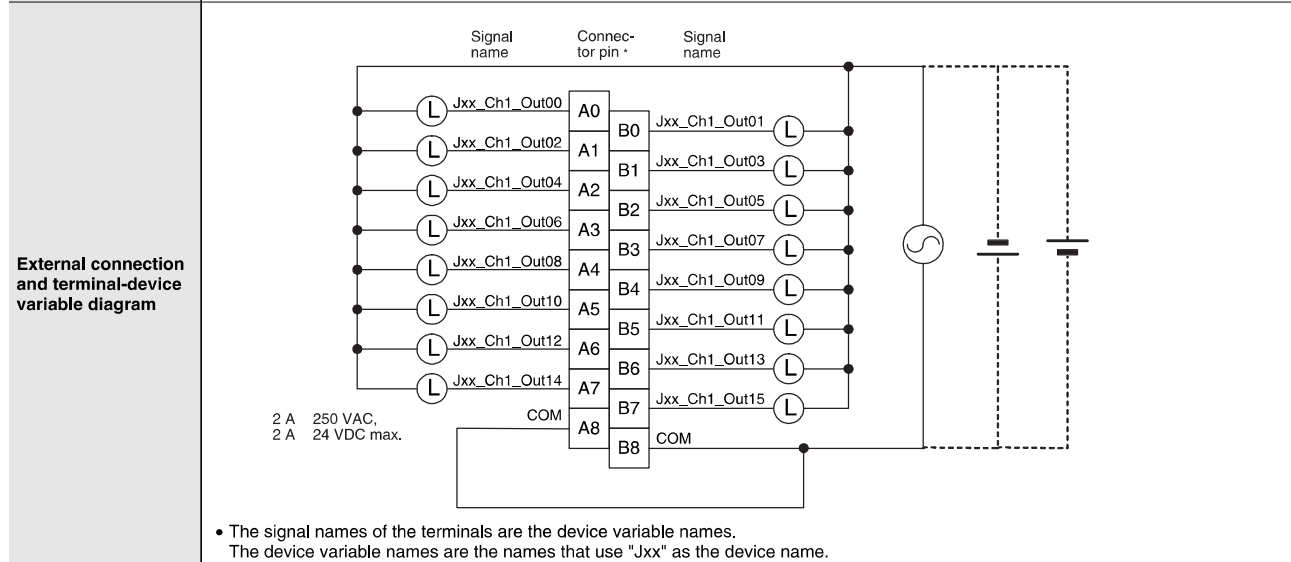
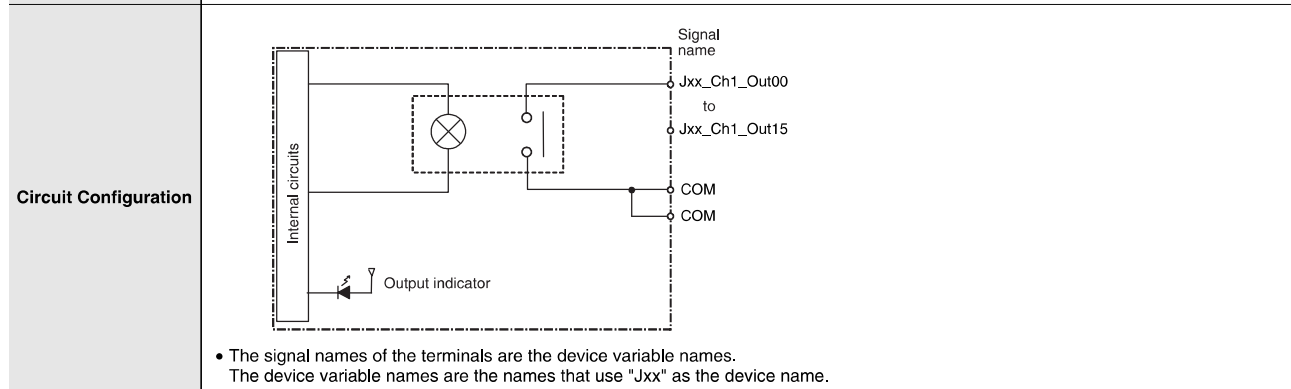

* Terminal numbers A0 to A8 and B0 to B8 are used in the external connection and terminal-device variable diagrams. They are not printed on the Units.

CJ1W-OA201 Triac Output Unit (8 Points)

Name	8-point Triac Output Unit with Terminal Block
Model	CJ1W-OA201
Max. Switching Capacity	0.6 A 250 VAC, 50/60 Hz (2.4 A/Unit)
Max. Inrush Current	15 A (pulse width: 10 ms max.)
Min. Switching Capacity	50 mA 75 VAC
Leakage Current	1.5 mA (200 VAC) max.
Residual Voltage	1.6 VAC max.
ON Response Time	1 ms max.
OFF Response Time	1/2 of load frequency + 1 ms or less.
Number of Circuits	8 (8 points/common, 1 circuit)
Surge Protector	C.R Absorber + Surge Absorber
Fuses	5 A (1/common, 1 used) The fuse cannot be replaced by the user.
Insulation Resistance	20 MΩ between the external terminals and the GR terminal (500 VDC)
Dielectric Strength	2,000 VAC between the external terminals and the GR terminal for 1 minute at a leakage current of 10 mA max.
Internal Current Consumption	220 mA max.
Weight	150 g max.

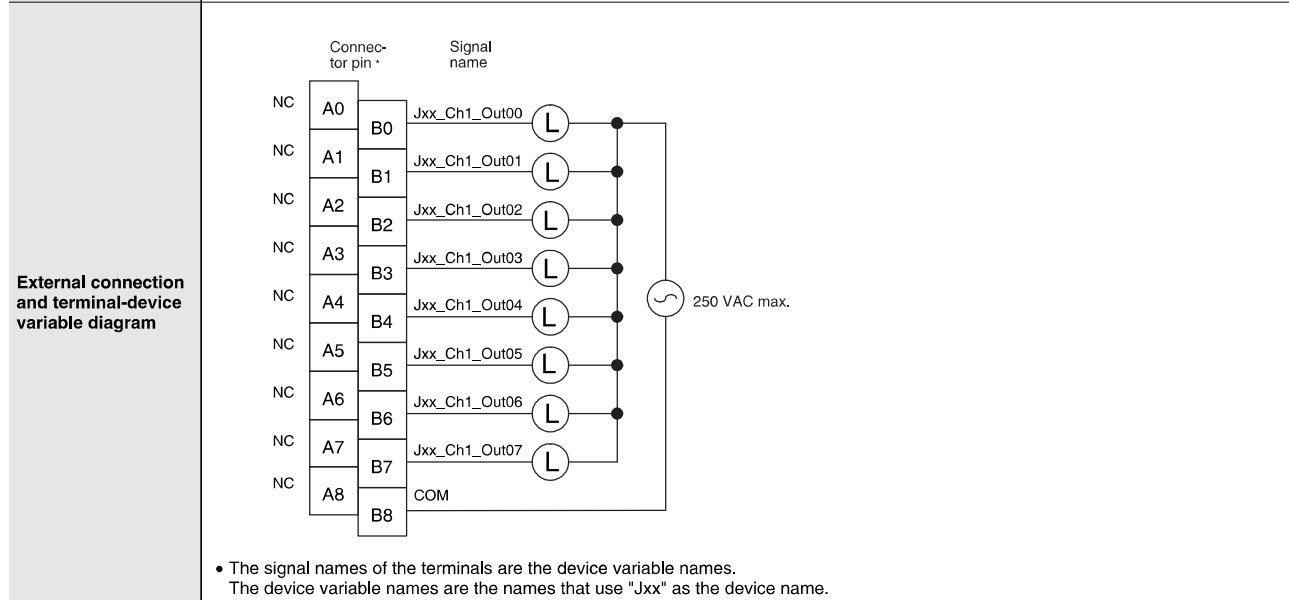
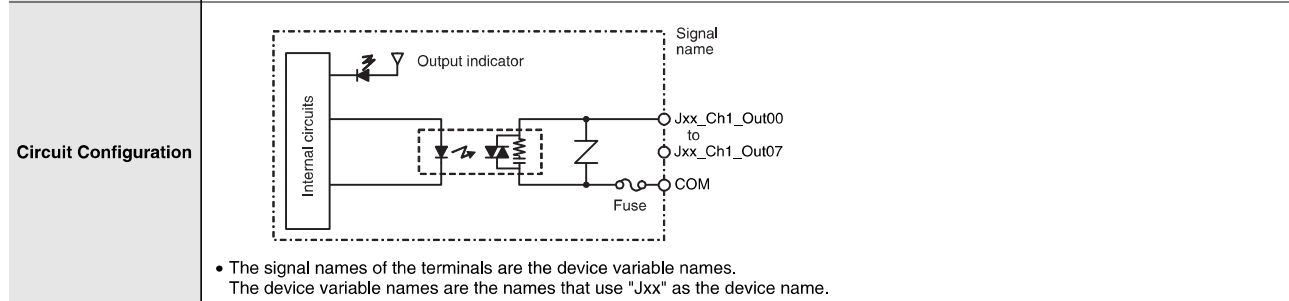

* Terminal numbers A0 to A8 and B0 to B8 are used in the external connection and terminal-device variable diagrams. They are not printed on the Units.

Note: Although 16 I/O bits (1 word) are allocated, only 8 of these can be used for external I/O.

CJ1W-OD201 Transistor Output Unit (8 Points)

Name	8-point Transistor Output Unit with Terminal Block (Sinking Outputs)
Model	CJ1W-OD201
Rated Voltage	12 to 24 VDC
Operating Load Voltage Range	10.2 to 26.4 VDC
Maximum Load Current	2.0 A/point, 8.0 A/Unit
Maximum Inrush Current	10 A/point, 10 ms max.
Leakage Current	0.1 mA max.
Residual Voltage	1.5 V max.
ON Response Time	0.5 ms max.
OFF Response Time	1.0 ms max.
Insulation Resistance	20 MΩ between the external terminals and the GR terminal (100 VDC)
Dielectric Strength	1,000 VAC between the external terminals and the GR terminal for 1 minute at a leakage current of 10 mA max.
Number of Circuits	8 (4 points/common, 2 circuits)
Internal Current Consumption	90 mA max.
Fuse	6.3 A (1/common, 2 used) The fuse cannot be replaced by the user.
External Power Supply	10.2 to 26.4 VDC, 10 mA min.
Weight	110 g max.

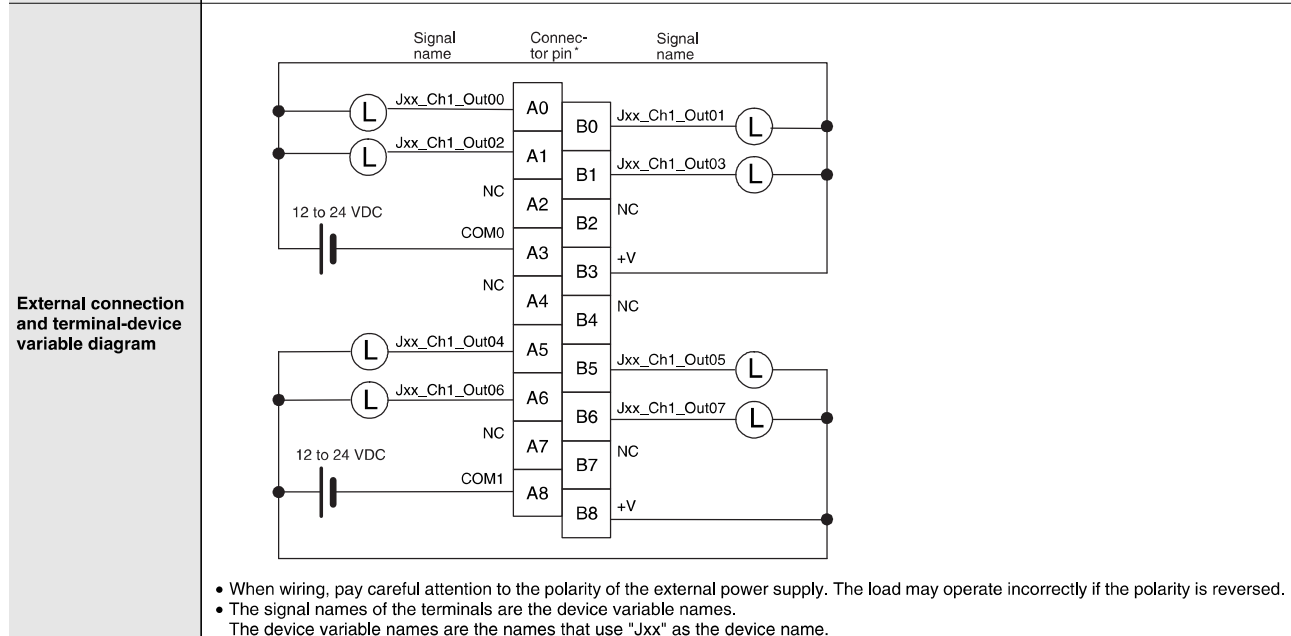
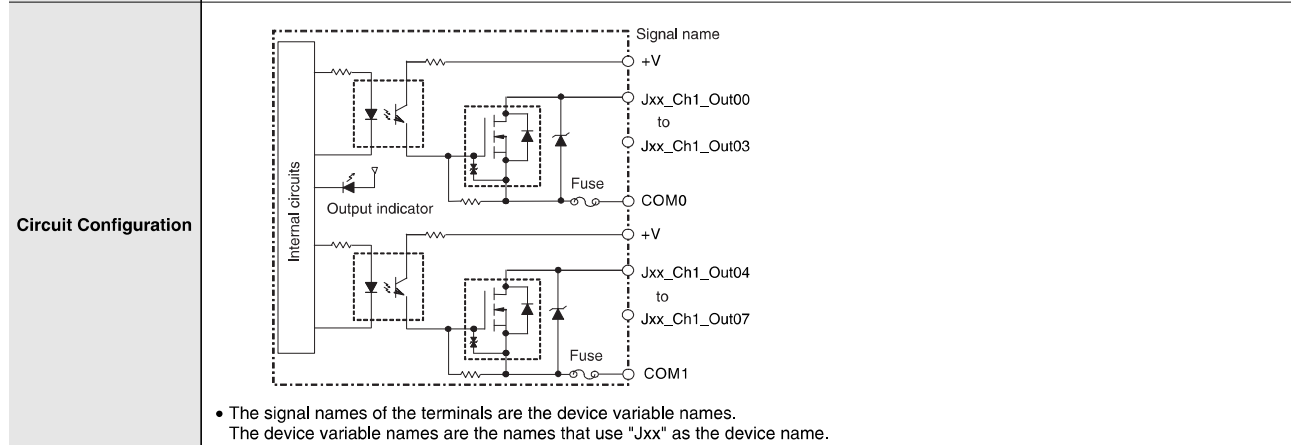

* Terminal numbers A0 to A8 and B0 to B8 are used in the external connection and terminal-device variable diagrams. They are not printed on the Units.
Note: Although 16 I/O bits (1 word) are allocated, only 8 of these can be used for external I/O.

CJ1W-OD203 Transistor Output Unit (8 Points)

Name	8-point Transistor Output Unit with Terminal Block (Sinking Outputs)
Model	CJ1W-OD203
Rated Voltage	12 to 24 VDC
Operating Load Voltage Range	10.2 to 26.4 VDC
Maximum Load Current	0.5 A/point, 4.0 A/Unit
Maximum Inrush Current	4.0 A/point, 10 ms max.
Leakage Current	0.1 mA max.
Residual Voltage	1.5 V max.
ON Response Time	0.1 ms max.
OFF Response Time	0.8 ms max.
Insulation Resistance	20 MΩ between the external terminals and the GR terminal (100 VDC)
Dielectric Strength	1,000 VAC between the external terminals and the GR terminal for 1 minute at a leakage current of 10 mA max.
Number of Circuits	8 (8 points/common, 1 circuit)
Internal Current Consumption	100 mA max.
Fuse	None
External Power Supply	10.2 to 26.4 VDC, 20 mA min.
Weight	110 g max.

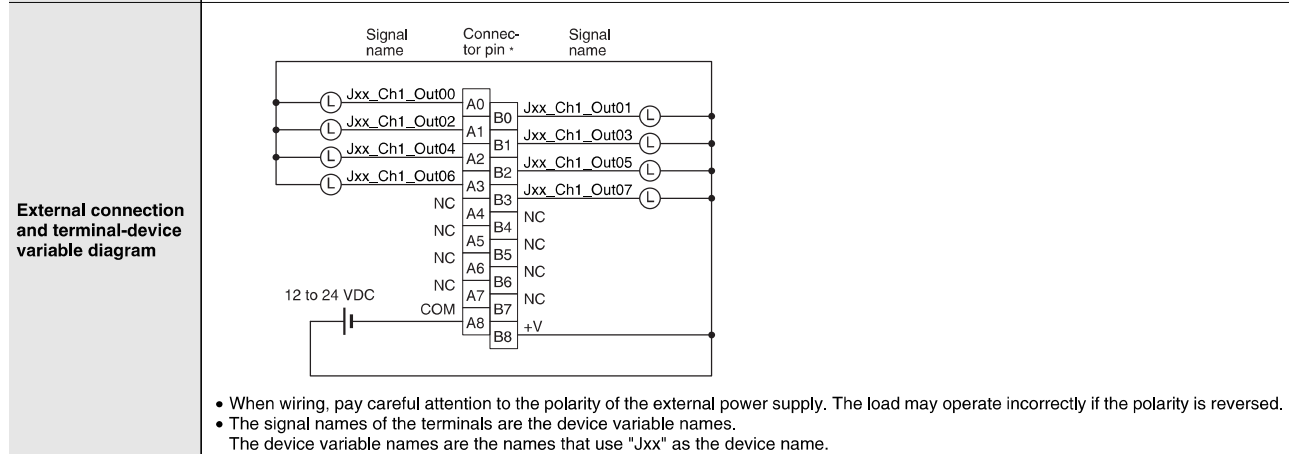
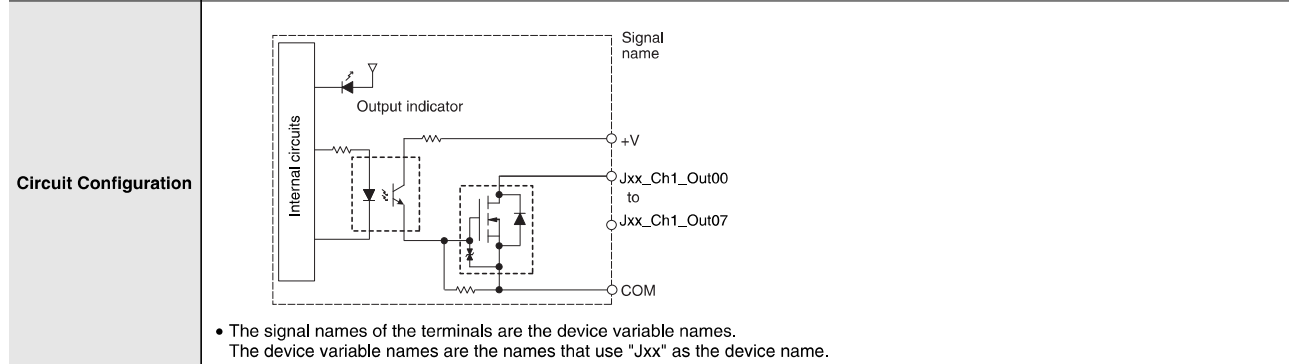

* Terminal numbers A0 to A8 and B0 to B8 are used in the external connection and terminal-device variable diagrams. They are not printed on the Units.

Note: Although 16 I/O bits (1 word) are allocated, only 8 of these can be used for external I/O.

CJ1W-OD211 Transistor Output Unit (16 Points)

Name	16-point Transistor Output Unit with Terminal Block (Sinking Outputs)
Model	CJ1W-OD211
Rated Voltage	12 to 24 VDC
Operating Load Voltage Range	10.2 to 26.4 VDC
Maximum Load Current	0.5 A/point, 5.0 A/Unit
Maximum Inrush Current	4.0 A/point, 10 ms max.
Leakage Current	0.1 mA max.
Residual Voltage	1.5 V max.
ON Response Time	0.1 ms max.
OFF Response Time	0.8 ms max.
Insulation Resistance	20 MΩ between the external terminals and the GR terminal (100 VDC)
Dielectric Strength	1,000 VAC between the external terminals and the GR terminal for 1 minute at a leakage current of 10 mA max.
Number of Circuits	16 (16 points/common, 1 circuit)
Internal Current Consumption	5 VDC 100 mA max.
Fuse	None
External Power Supply	10.2 to 26.4 VDC, 20 mA min.
Weight	110 g max.

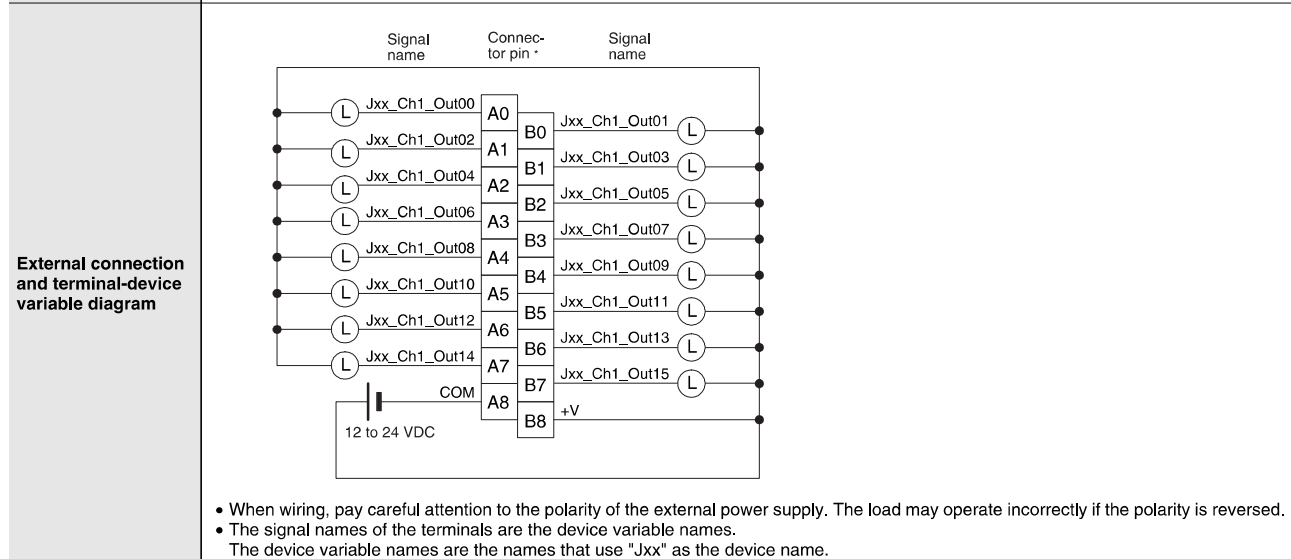
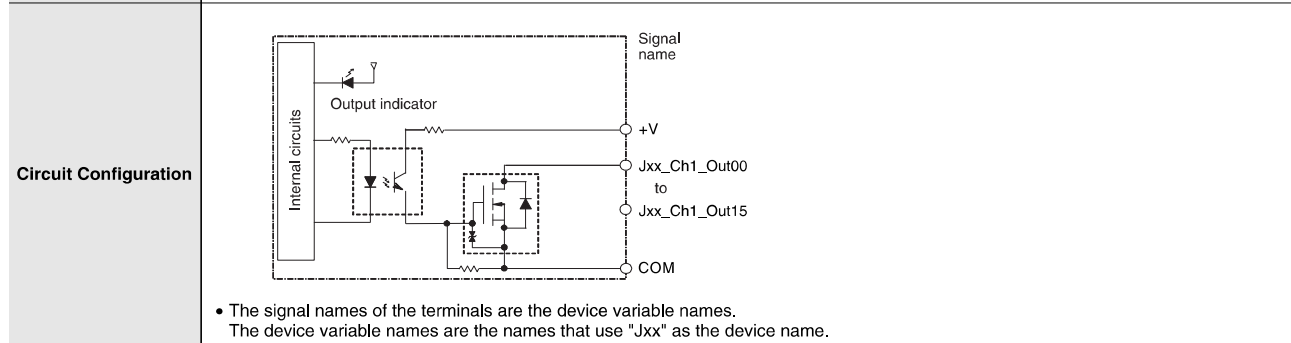

* Terminal numbers A0 to A8 and B0 to B8 are used in the external connection and terminal-device variable diagrams. They are not printed on the Units.

CJ1W-OD213 Transistor Output Unit (16 Points)

Name	16-point Transistor Output Unit with Terminal Block (Sinking Outputs)
Model	CJ1W-OD213
Rated Voltage	24 VDC
Operating Load Voltage Range	20.4 to 26.4 VDC
Maximum Load Current	0.5 A/point, 5.0 A/Unit
Maximum Inrush Current	4.0 A/point, 10 ms max.
Leakage Current	0.1 mA max.
Residual Voltage	1.5 V max.
ON Response Time	15 μs max.
OFF Response Time	80 μs max.
Insulation Resistance	20 MΩ between the external terminals and the GR terminal (100 VDC)
Dielectric Strength	1,000 VAC between the external terminals and the GR terminal for 1 minute at a leakage current of 10 mA max.
Number of Circuits	16 (16 points/common, 1 circuit)
Internal Current Consumption	5 VDC 150 mA max.
Fuse	None
External Power Supply	20.4 to 26.4 VDC, 55 mA min.
Weight	110 g max.

Circuit Configuration

• The signal names of the terminals are the device variable names.
The device variable names are the names that use "Jxx" as the device name.

External connection and terminal-device variable diagram

• When wiring, pay careful attention to the polarity of the external power supply. The load may operate incorrectly if the polarity is reversed.
• The signal names of the terminals are the device variable names.
The device variable names are the names that use "Jxx" as the device name.

* Terminal numbers A0 to A8 and B0 to B8 are used in the external connection and terminal-device variable diagrams. They are not printed on the Units.

CJ1W-OD231 Transistor Output Unit (32 Points)

Name	32-point Transistor Output Unit with Fujitsu Connector (Sinking Outputs)
Model	CJ1W-OD231
Rated Voltage	12 to 24 VDC
Operating Load Voltage Range	10.2 to 26.4 VDC
Maximum Load Current	0.5 A/point, 2.0 A/common, 4.0 A/Unit
Maximum Inrush Current	4.0 A/point, 10 ms max.
Leakage Current	0.1 mA max.
Residual Voltage	1.5 V max.
ON Response Time	0.1 ms max.
OFF Response Time	0.8 ms max.
Insulation Resistance	20 MΩ between the external terminals and the GR terminal (100 VDC)
Dielectric Strength	1,000 VAC between the external terminals and the GR terminal for 1 minute at a leakage current of 10 mA max.
Number of Circuits	32 (16 points/common, 2 circuits)
Internal Current Consumption	5 VDC 140 mA max.
Fuse	None
External Power Supply	10.2 to 26.4 VDC, 30 mA min.
Weight	70 g max.
Accessories	None

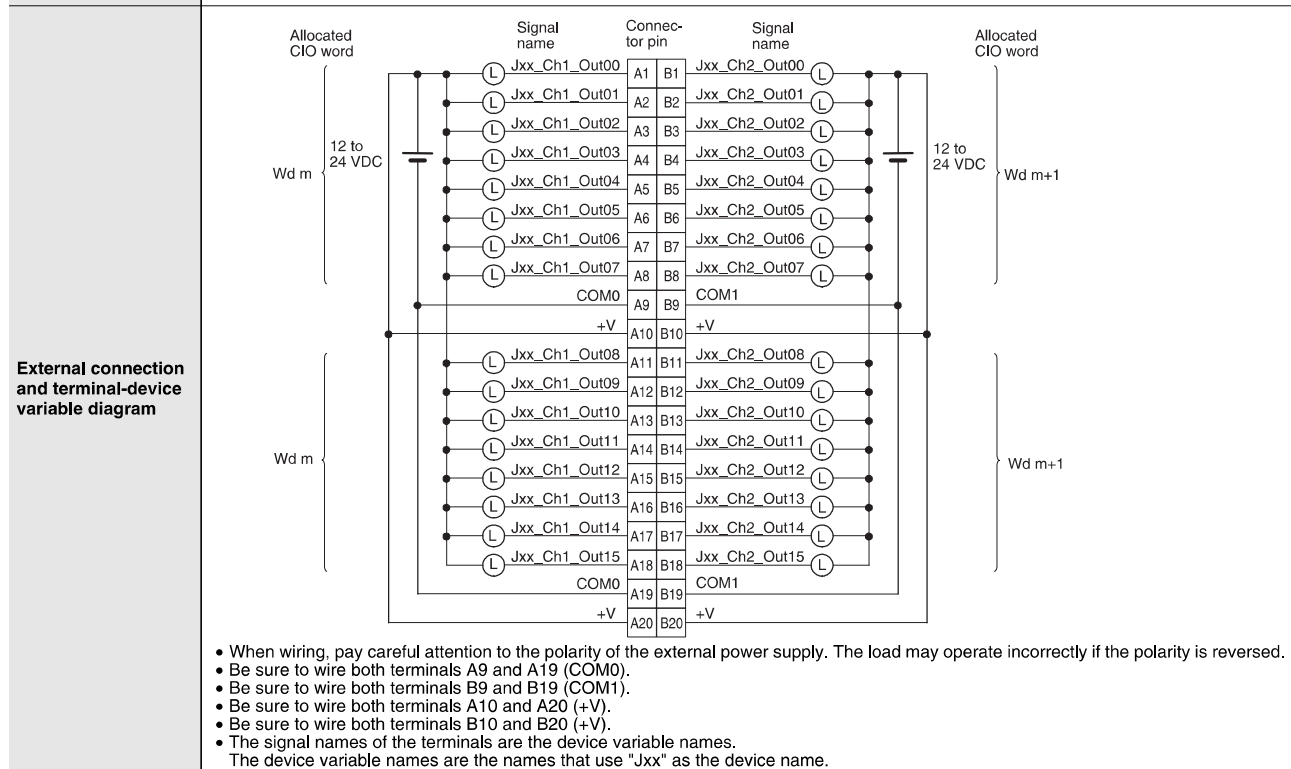
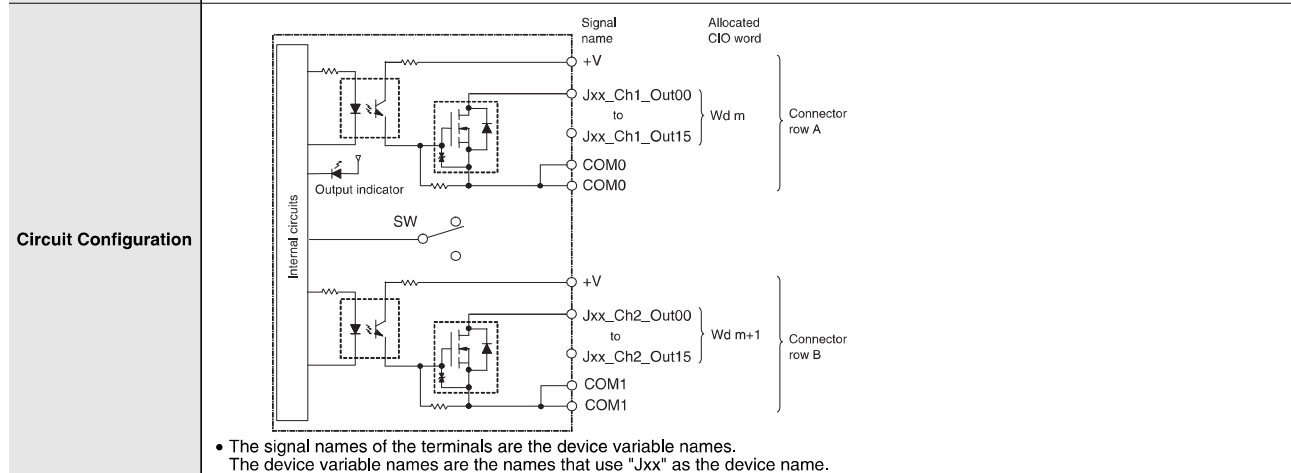

CJ1W-OD233 Transistor Output Unit (32 Points)

Name	32-point Transistor Output Unit with MIL Connector (Sinking Outputs)
Model	CJ1W-OD233
Rated Voltage	12 to 24 VDC
Operating Load Voltage Range	10.2 to 26.4 VDC
Maximum Load Current	0.5 A/point, 2 A/common, 4 A/Unit
Maximum Inrush Current	4.0 A/point, 10 ms max.
Leakage Current	0.1 mA max.
Residual Voltage	1.5 V max.
ON Response Time	0.1 ms max.
OFF Response Time	0.8 ms max.
Insulation Resistance	20 MΩ between the external terminals and the GR terminal (100 VDC)
Dielectric Strength	1,000 VAC between the external terminals and the GR terminal for 1 minute at a leakage current of 10 mA max.
Number of Circuits	32 (16 points/common, 2 circuits)
Internal Current Consumption	140 mA max.
Fuse	None
External Power Supply	10.2 to 26.4 VDC, 30 mA min.
Weight	70 g max.

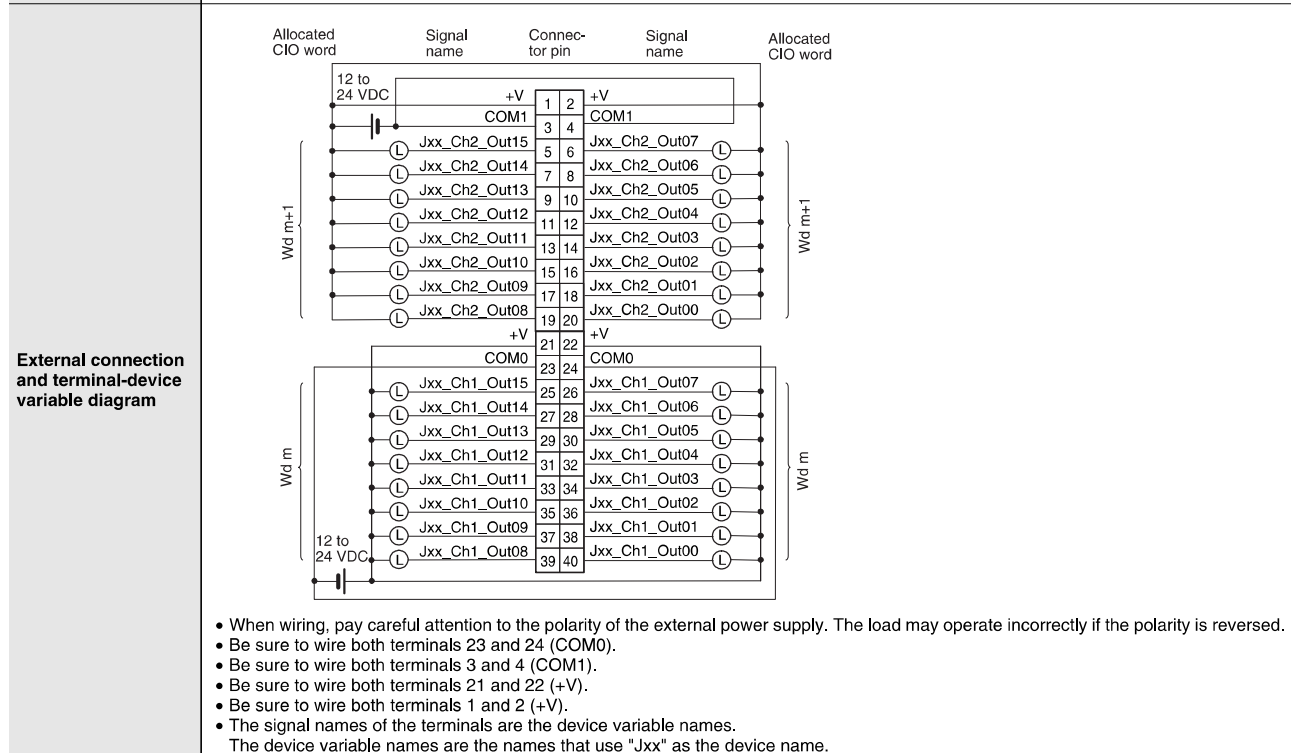
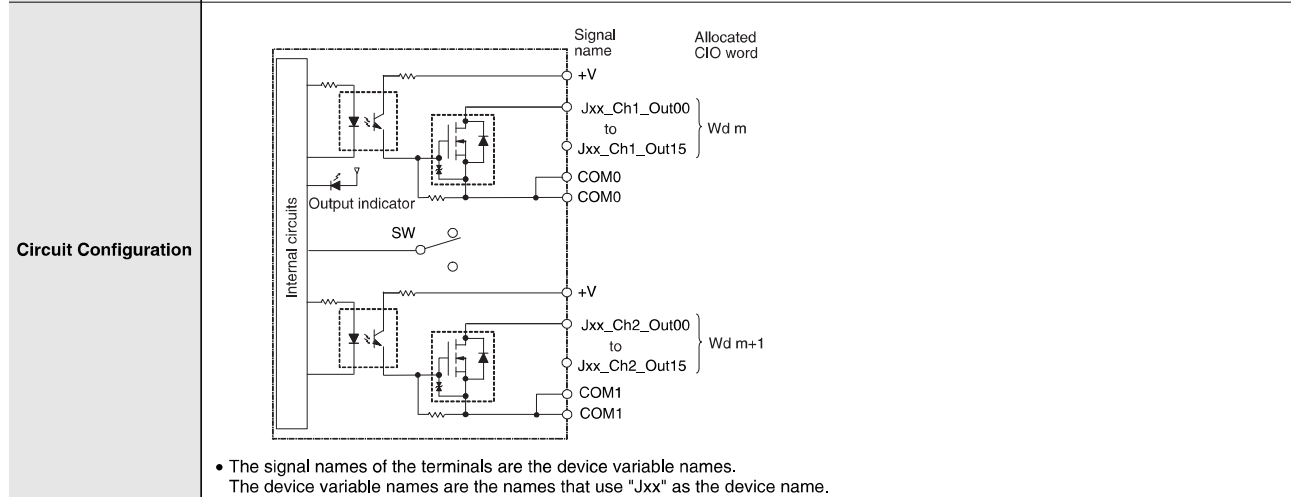

CJ1W-OD234 Transistor Output Unit (32 Points)

Name	32-point Transistor Output Unit with MIL Connector (Sinking Outputs)
Model	CJ1W-OD234
Rated Voltage	24 VDC
Operating Load Voltage Range	20.4 to 26.4 VDC
Maximum Load Current	0.5 A/point, 2 A/common, 4 A/Unit
Maximum Inrush Current	4.0 A/point, 10 ms max.
Leakage Current	0.1 mA max.
Residual Voltage	1.5 V max.
ON Response Time	15 μs max.
OFF Response Time	80 μs max.
Insulation Resistance	20 MΩ between the external terminals and the GR terminal (100 VDC)
Dielectric Strength	1,000 VAC between the external terminals and the GR terminal for 1 minute at a leakage current of 10 mA max.
Number of Circuits	32 (16 points/common, 2 circuits)
Internal Current Consumption	220 mA max.
Fuse	None
External Power Supply	20.4 to 26.4 VDC, 110 mA min.
Weight	70 g max.

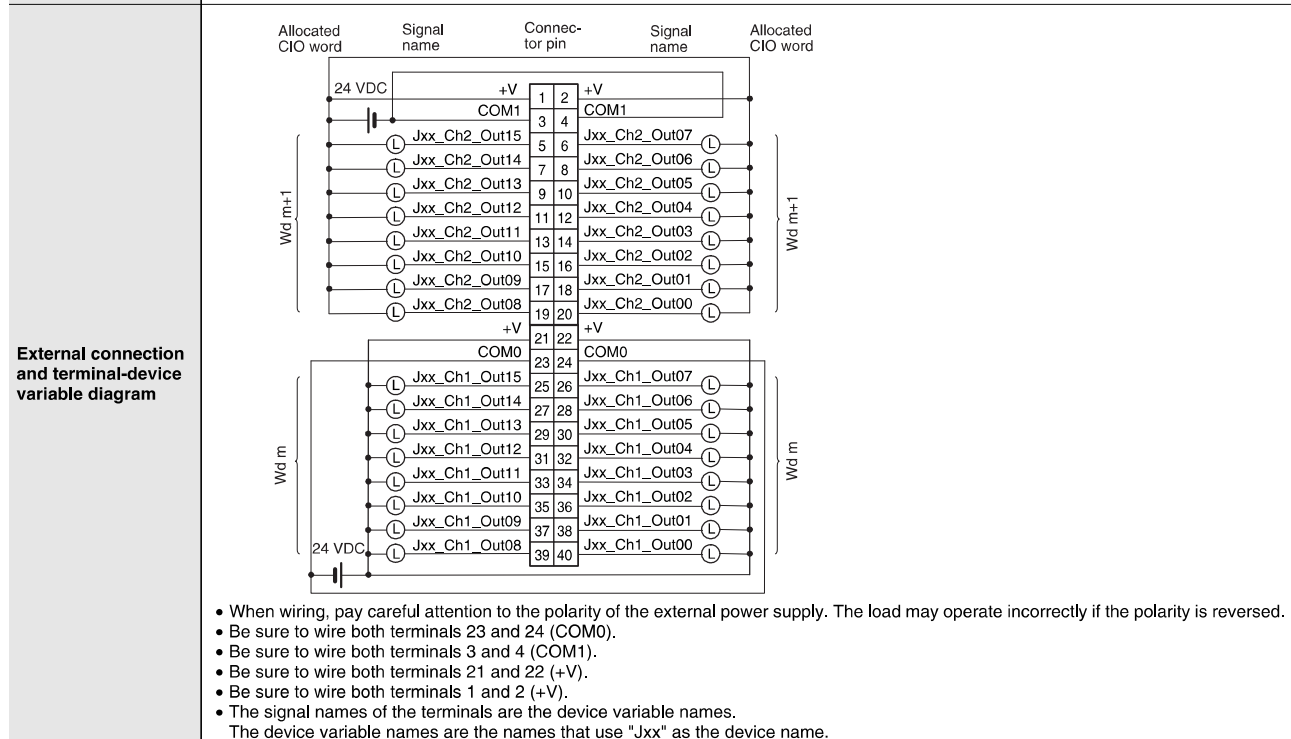
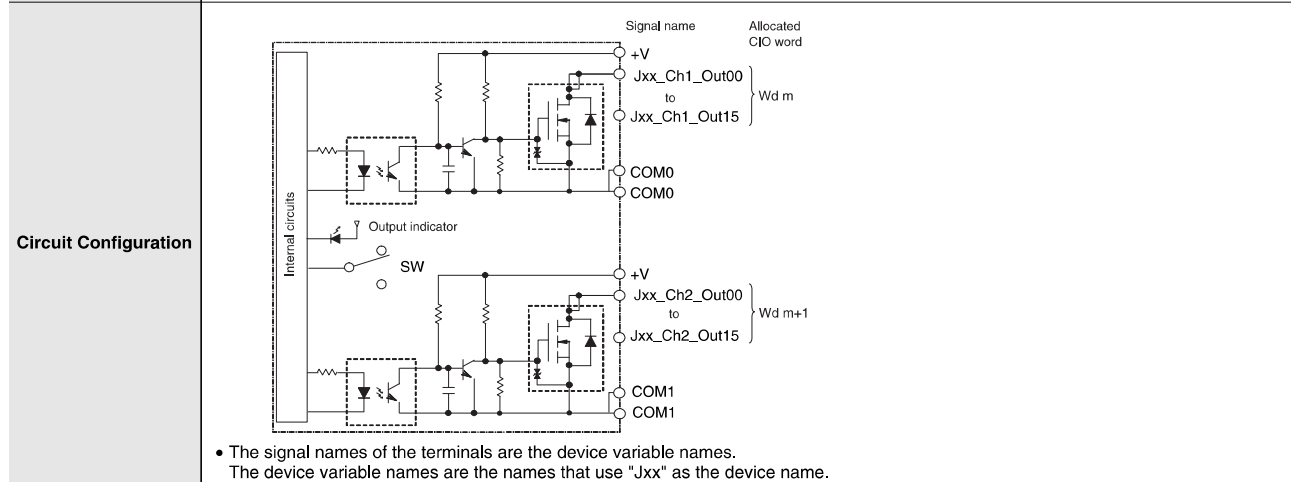

CJ1W-OD261 Transistor Output Unit (64 Points)

Name	64-point Transistor Output Unit with Fujitsu Connectors (Sinking Outputs)
Model	CJ1W-OD261
Rated Voltage	12 to 24 VDC
Operating Load Voltage Range	10.2 to 26.4 VDC
Maximum Load Current	0.3 A/point, 1.6 A/common, 6.4 A/Unit
Maximum Inrush Current	3.0 A/point, 10 ms max.
Leakage Current	0.1 mA max.
Residual Voltage	1.5 V max.
ON Response Time	0.5 ms max.
OFF Response Time	1.0 ms max.
Insulation Resistance	20 MΩ between the external terminals and the GR terminal (100 VDC)
Dielectric Strength	1,000 VAC between the external terminals and the GR terminal for 1 minute at a leakage current of 10 mA max.
Number of Circuits	64 (16 points/common, 4 circuits)
Internal Current Consumption	5 VDC, 170 mA max.
Fuse	None
External Power Supply	10.2 to 26.4 VDC, 50 mA min.
Weight	110 g max.
Accessories	None

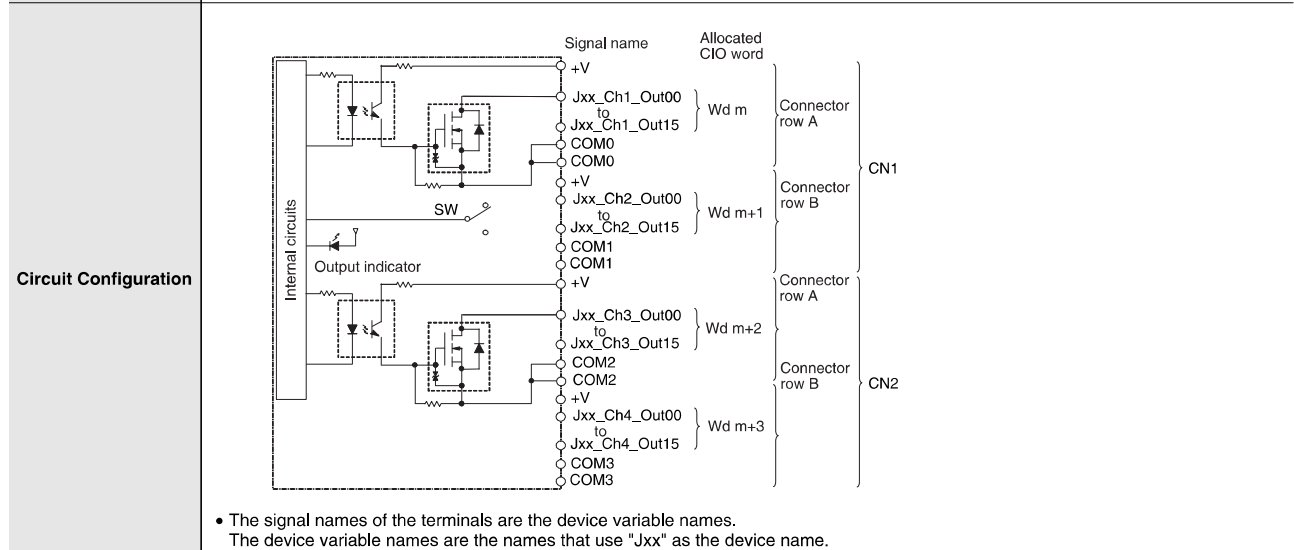

External connection and terminal-device variable diagram

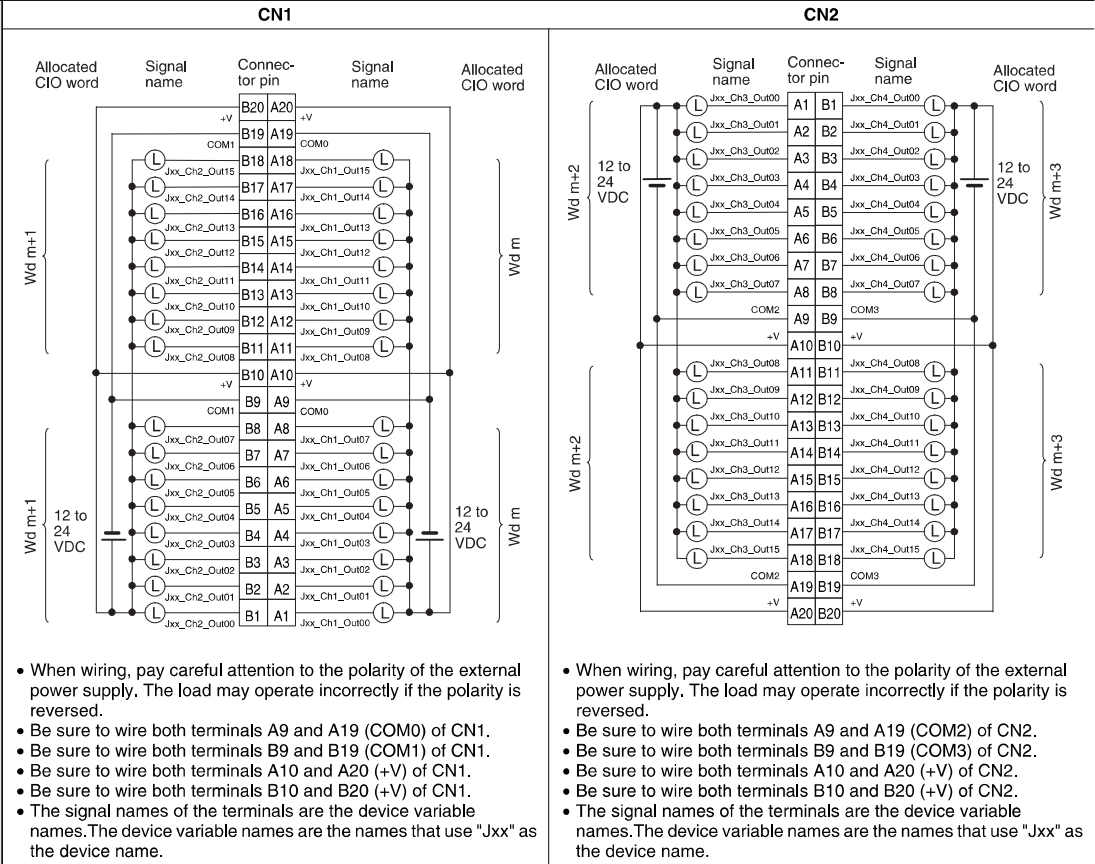

CJ1W-OD263 Transistor Output Unit (64 Points)

Name	64-point Transistor Output Unit with MIL Connectors (Sinking Outputs)
Model	CJ1W-OD263
Rated Voltage	12 to 24 VDC
Operating Load Voltage Range	10.2 to 26.4 VDC
Maximum Load Current	0.3 A/point, 1.6 A/common, 6.4 A/Unit
Maximum Inrush Current	3.0 A/point, 10 ms max.
Leakage Current	0.1 mA max.
Residual Voltage	1.5 V max.
ON Response Time	0.5 ms max.
OFF Response Time	1.0 ms max.
Insulation Resistance	20 MΩ between the external terminals and the GR terminal (100 VDC)
Dielectric Strength	1,000 VAC between the external terminals and the GR terminal for 1 minute at a leakage current of 10 mA max.
Number of Circuits	64 (16 points/common, 4 circuits)
Internal Current Consumption	170 mA max.
Fuse	None
External Power Supply	10.2 to 26.4 VDC, 50 mA min.
Weight	110 g max.

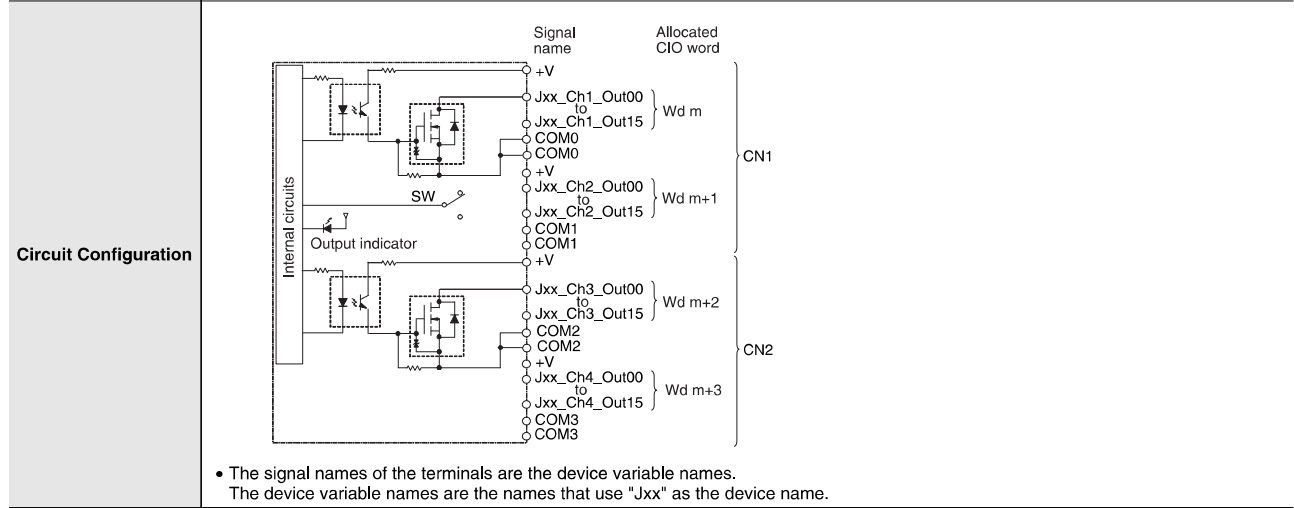

External connection and terminal-device variable diagram

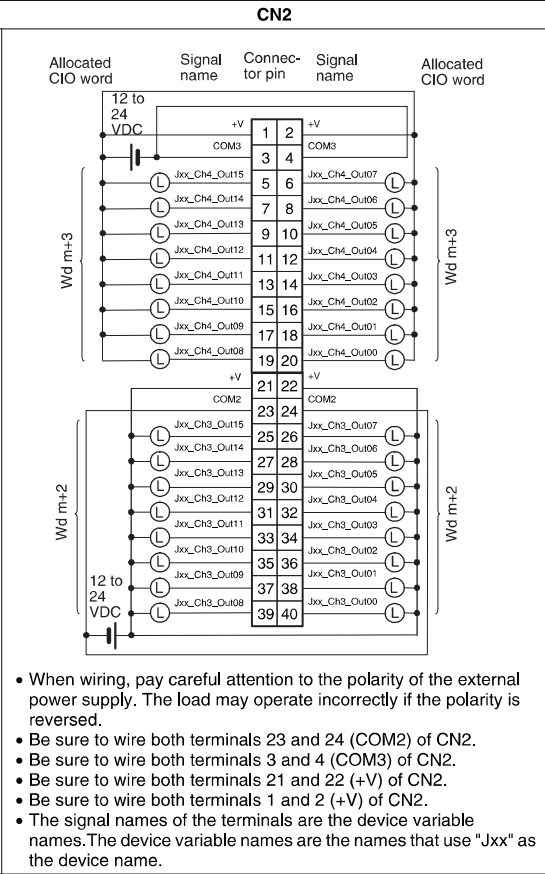
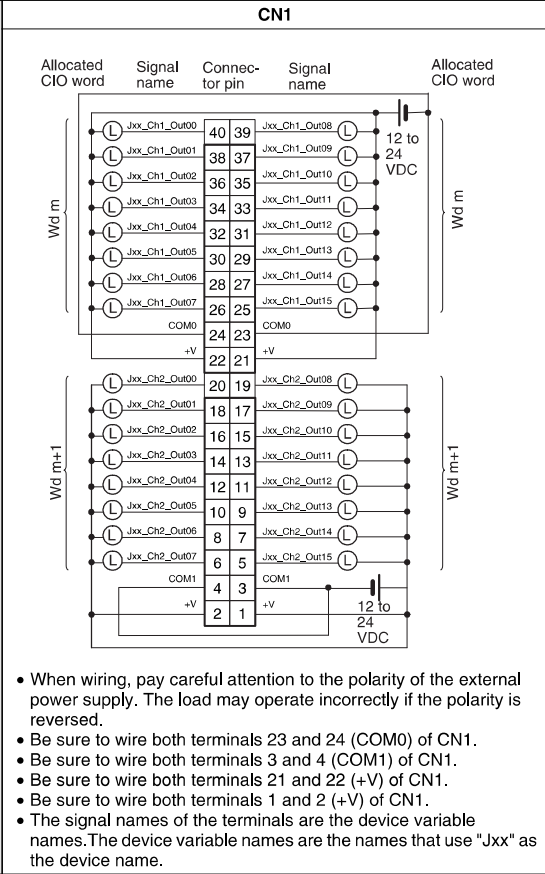

CJ1W-OD202 Transistor Output Unit (8 Points)

Name	8-point Transistor Output Unit with Terminal Block (Sourcing Outputs)
Model	CJ1W-OD202
Rated Voltage	24 VDC
Operating Load Voltage Range	20.4 to 26.4 VDC
Maximum Load Current	2 A/point, 8 A/Unit
Leakage Current	0.1 mA max.
Residual Voltage	1.5 V max.
ON Response Time	0.5 ms max.
OFF Response Time	1.0 ms max.
Load Short-circuit Protection	Detection current: 6 A min. Automatic restart after error clearance.
Line Disconnection Detection	Detection current: 200 mA
Insulation Resistance	20 MΩ between the external terminals and the GR terminal (100 VDC)
Dielectric Strength	1,000 VAC between the external terminals and the GR terminal for 1 minute at a leakage current of 10 mA max.
Number of Circuits	8 (4 points/common, 2 circuits)
Internal Current Consumption	110 mA max.
Fuse	None
External Power Supply	20.4 to 26.4 VDC, 50 mA min.
Weight	120 g max.

Circuit Configuration

- When overcurrent or line disconnection is detected, the ERR indicator will light, and the corresponding bit (two points per bit) in the Basic I/O Unit Information Area (A050 to A069) will change to TRUE.
- The signal names of the terminals are the device variable names. The device variable names are the names that use "Jxx" as the device name.

External connection and terminal-device variable diagram

- When wiring, pay careful attention to the polarity of the external power supply. The load may operate incorrectly if the polarity is reversed.
- The signal names of the terminals are the device variable names. The device variable names are the names that use "Jxx" as the device name.

* Terminal numbers A0 to A8 and B0 to B8 are used in the external connection and terminal-device variable diagrams. They are not printed on the Units.

Note: Although 16 I/O bits (1 word) are allocated, only 8 of these can be used for external I/O.

CJ1W-OD204 Transistor Output Unit (8 Points)

Name	8-point Transistor Output Unit with Terminal Block (Sourcing Outputs)
Model	CJ1W-OD204
Rated Voltage	24 VDC
Operating Load Voltage Range	20.4 to 26.4 VDC
Maximum Load Current	0.5 A/point, 4.0 A/Unit
Leakage Current	0.1 mA max.
Residual Voltage	1.5 V max.
ON Response Time	0.5 ms max.
OFF Response Time	1.0 ms max.
Load Short-circuit Protection	Detection current: 0.7 to 2.5 A Automatic restart after error clearance.
Insulation Resistance	20 MΩ between the external terminals and the GR terminal (100 VDC)
Dielectric Strength	1,000 VAC between the external terminals and the GR terminal for 1 minute at a leakage current of 10 mA max.
Number of Circuits	8 (8 points/common, 1 circuit)
Internal Current Consumption	5 VDC, 100 mA max.
Fuse	None
External Power Supply	20.4 to 26.4 VDC, 40 mA min.
Weight	120 g max.

Circuit Configuration

- When overcurrent is detected, the ERR indicator will light, and the corresponding bit in the Basic I/O Unit Information Area (A050 to A069) will change to TRUE.
- The signal names of the terminals are the device variable names. The device variable names are the names that use "Jxx" as the device name.

External connection and terminal-device variable diagram

- When wiring, pay careful attention to the polarity of the external power supply. The load may operate incorrectly if the polarity is reversed.
- The signal names of the terminals are the device variable names. The device variable names are the names that use "Jxx" as the device name.

* Terminal numbers A0 to A8 and B0 to B8 are used in the external connection and terminal-device variable diagrams. They are not printed on the Units.

Note: Although 16 I/O bits (1 word) are allocated, only 8 of these can be used for external I/O.

CJ1W-OD212 Transistor Output Unit (16 Points)

Name	16-point Transistor Output Unit with Terminal Block (Sourcing Outputs)
Model	CJ1W-OD212
Rated Voltage	24 VDC
Operating Load Voltage Range	20.4 to 26.4 VDC
Maximum Load Current	0.5 A/point, 5.0 A/Unit
Maximum Inrush Current	0.1 mA max.
Leakage Current	1.5 V max.
ON Response Time	0.5 ms max.
OFF Response Time	1.0 ms max.
Load Short-circuit Protection	Detection current: 0.7 to 2.5 A Automatic restart after error clearance.
Insulation Resistance	20 MΩ between the external terminals and the GR terminal (100 VDC)
Dielectric Strength	1,000 VAC between the external terminals and the GR terminal for 1 minute at a leakage current of 10 mA max.
Number of Circuits	16 (16 points/common, 1 circuit)
Internal Current Consumption	5 VDC, 100 mA max.
External Power Supply	20.4 to 26.4 VDC, 40 mA min.
Weight	120 g max.

Circuit Configuration

- When overcurrent is detected, the ERR indicator will light, and the corresponding bit in the Basic I/O Unit Information Area (A050 to A069) will change to TRUE.
- The signal names of the terminals are the device variable names. The device variable names are the names that use "Jxx" as the device name.

External connection and terminal-device variable diagram

- When wiring, pay careful attention to the polarity of the external power supply. The load may operate incorrectly if the polarity is reversed.
- The signal names of the terminals are the device variable names. The device variable names are the names that use "Jxx" as the device name.

* Terminal numbers A0 to A8 and B0 to B8 are used in the external connection and terminal-device variable diagrams. They are not printed on the Units.

CJ1W-OD232 Transistor Output Unit (32 Points)

Name	32-point Transistor Output Unit with MIL Connector (Sourcing Outputs)
Model	CJ1W-OD232
Rated Voltage	24 VDC
Operating Load Voltage Range	20.4 to 26.4 VDC
Maximum Load Current	0.5 A/point, 2.0 A/common, 4.0 A/Unit
Leakage Current	0.1 mA max.
Residual Voltage	1.5 V max.
ON Response Time	0.5 ms max.
OFF Response Time	1.0 ms max.
Load Short-circuit Protection	Detection current: 0.7 to 2.5 A Automatic restart after error clearance.
Insulation Resistance	20 MΩ between the external terminals and the GR terminal (100 VDC)
Dielectric Strength	1,000 VAC between the external terminals and the GR terminal for 1 minute at a leakage current of 10 mA max.
Number of Circuits	32 (16 points/common, 2 circuits)
Internal Current Consumption	5 VDC 150 mA max.
External Power Supply	20.4 to 26.4 VDC, 70 mA min.
Weight	80 g max.
Accessories	None

Circuit Configuration

- When overcurrent is detected, the ERR indicator will light, and the corresponding bit (bit allocated for each common) in the Basic I/O Unit Information Area (A050 to A069) will change to TRUE.
- The signal names of the terminals are the device variable names. The device variable names are the names that use "Jxx" as the device name.

External connection and terminal-device variable diagram

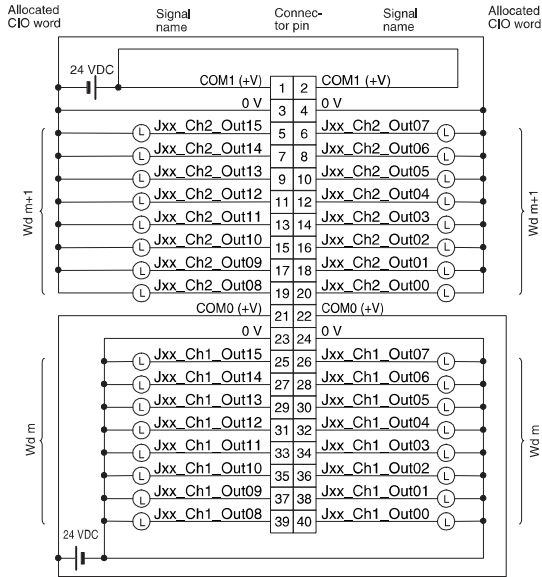

- When wiring, pay careful attention to the polarity of the external power supply. The load may operate incorrectly if the polarity is reversed.
- Be sure to wire both terminals 21 and 22 (COM0 (+V)).
- Be sure to wire both terminals 1 and 2 (COM1 (+V)).
- Be sure to wire both terminals 3 and 4 (0 V).
- Be sure to wire both terminals 23 and 24 (0 V).
- The signal names of the terminals are the device variable names.
The device variable names are the names that use "Jxx" as the device name.

CJ1W-OD262 Transistor Output Unit (64 Points)

Name	64-point Transistor Output Unit with MIL Connectors (Sourcing Outputs)
Model	CJ1W-OD262
Rated Voltage	12 to 24 VDC
Operating Load Voltage Range	10.2 to 26.4 VDC
Maximum Load Current	0.3 A/point, 1.6 A/common, 6.4 A/Unit
Maximum Inrush Current	3.0 A/point, 10 ms max.
Leakage Current	0.1 mA max.
Residual Voltage	1.5 V max.
ON Response Time	0.5 ms max.
OFF Response Time	1.0 ms max.
Insulation Resistance	20 MΩ between the external terminals and the GR terminal (100 VDC)
Dielectric Strength	1,000 VAC between the external terminals and the GR terminal for 1 minute at a leakage current of 10 mA max.
Number of Circuits	64 (16 points/common, 4 circuits)
Internal Current Consumption	170 mA max. (5 VDC)
Fuse	None
External Power Supply	10.2 to 26.4 VDC, 50 mA min.
Weight	110 g max.
Accessories	None

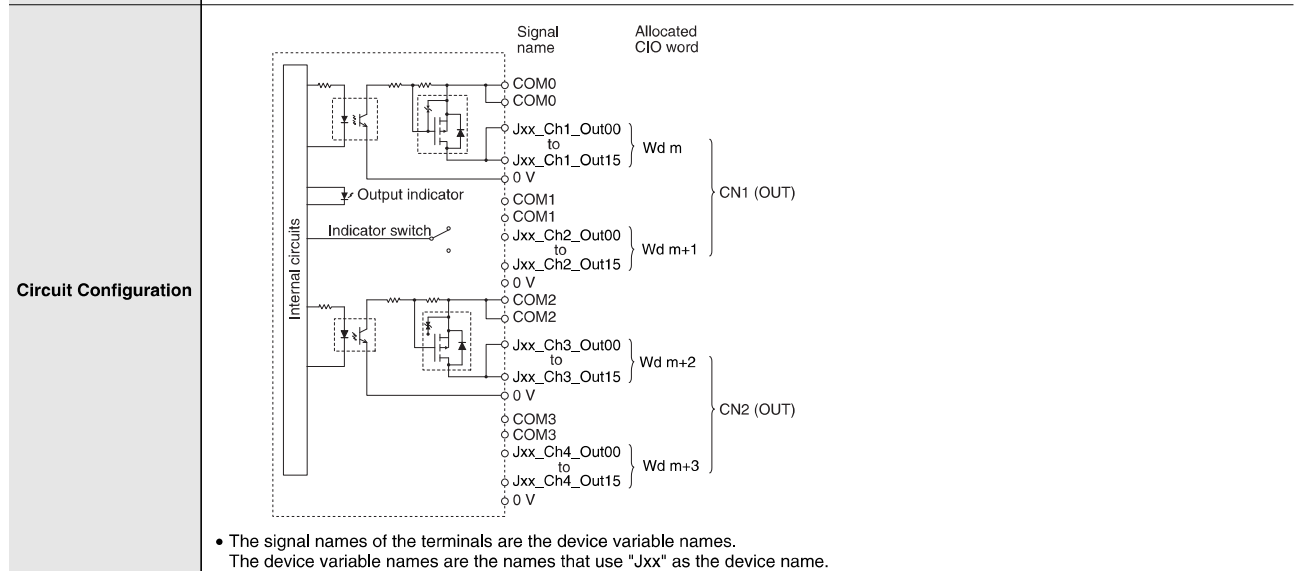

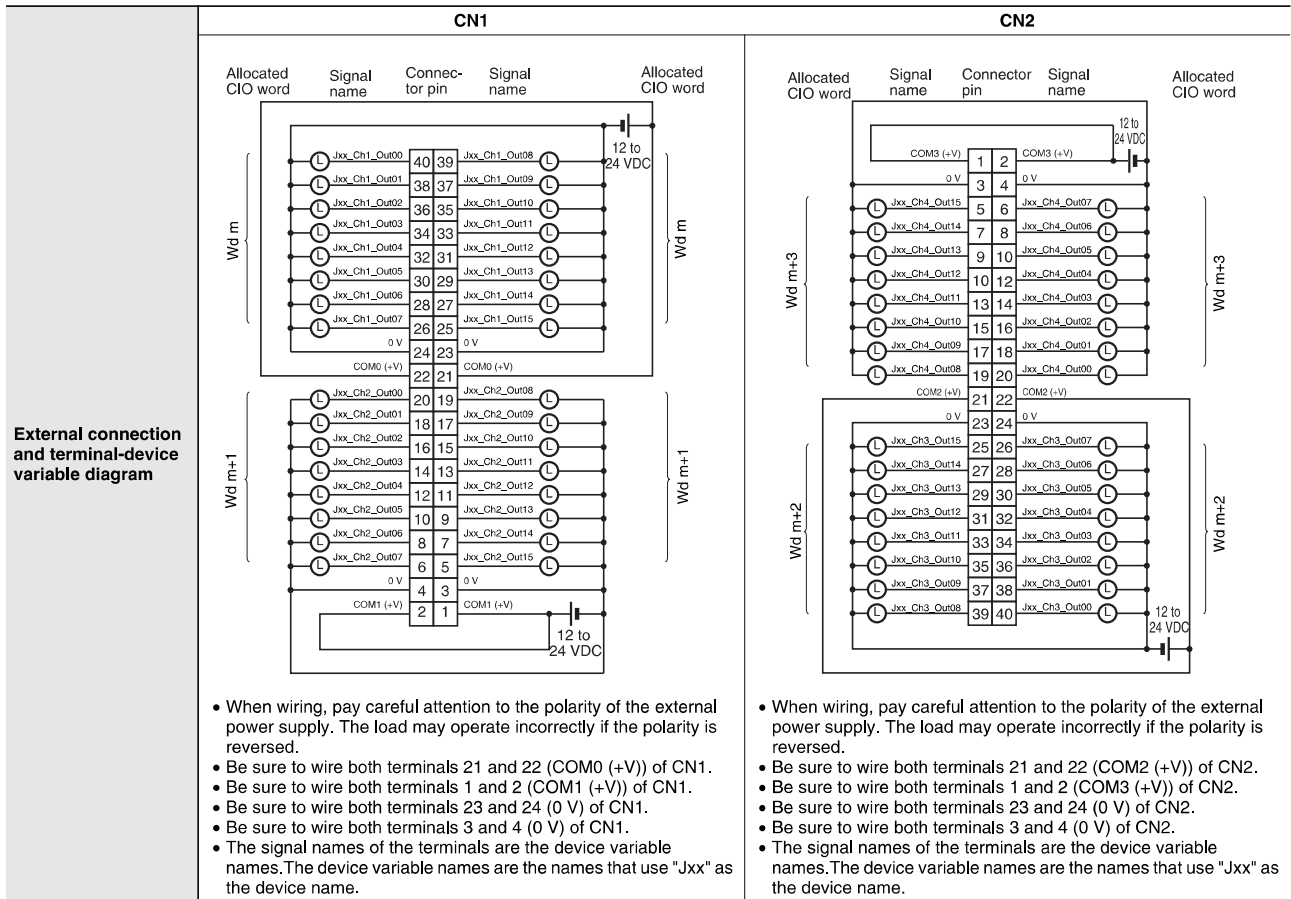

External connection and terminal-device variable diagram

- When wiring, pay careful attention to the polarity of the external power supply. The load may operate incorrectly if the polarity is reversed.
- Be sure to wire both terminals 21 and 22 (COM0 (+V)) of CN1.
- Be sure to wire both terminals 1 and 2 (COM1 (+V)) of CN1.
- Be sure to wire both terminals 23 and 24 (0 V) of CN1.
- Be sure to wire both terminals 3 and 4 (0 V) of CN1.
- The signal names of the terminals are the device variable names. The device variable names are the names that use "Jxx" as the device name.

- When wiring, pay careful attention to the polarity of the external power supply. The load may operate incorrectly if the polarity is reversed.
- Be sure to wire both terminals 21 and 22 (COM2 (+V)) of CN2.
- Be sure to wire both terminals 1 and 2 (COM3 (+V)) of CN2.
- Be sure to wire both terminals 23 and 24 (0 V) of CN2.
- Be sure to wire both terminals 3 and 4 (0 V) of CN2.
- The signal names of the terminals are the device variable names. The device variable names are the names that use "Jxx" as the device name.

Bit Allocations for Output Unit

8-point Output Unit

Allocated CIO word		Signal name (CJ/NJ)
CIO	Bit	
Wd m (Output)	00	OUT0/Jxx_Ch1_Out00
	01	OUT1/Jxx_Ch1_Out01
	:	:
	06	OUT6/Jxx_Ch1_Out06
	07	OUT7/Jxx_Ch1_Out07
	08	—
	09	—
	:	:
	14	—
	15	—

32-point Output Unit

Allocated CIO word		Signal name (CJ/NJ)
CIO	Bit	
Wd m (Output)	00	OUT0/Jxx_Ch1_Out00
	01	OUT1/Jxx_Ch1_Out01
	:	:
	14	OUT14/Jxx_Ch1_Out14
	15	OUT15/Jxx_Ch1_Out15
Wd m+1 (Output)	00	OUT0/Jxx_Ch2_Out00
	01	OUT1/Jxx_Ch2_Out01
	:	:
	14	OUT14/Jxx_Ch2_Out14
	15	OUT15/Jxx_Ch2_Out15

16-point Output Unit

Allocated CIO word		Signal name (CJ/NJ)
CIO	Bit	
Wd m (Output)	00	OUT0/Jxx_Ch1_Out00
	01	OUT1/Jxx_Ch1_Out01
	:	:
	14	OUT14/Jxx_Ch1_Out14
	15	OUT15/Jxx_Ch1_Out15

64-point Output Unit

Allocated CIO word		Signal name (CJ/NJ)
CIO	Bit	
Wd m (Output)	00	OUT0/Jxx_Ch1_Out00
	01	OUT1/Jxx_Ch1_Out01
	:	:
	14	OUT14/Jxx_Ch1_Out14
	15	OUT15/Jxx_Ch1_Out15
Wd m+1 (Output)	00	OUT0/Jxx_Ch2_Out00
	01	OUT1/Jxx_Ch2_Out01
	:	:
	14	OUT14/Jxx_Ch2_Out14
	15	OUT15/Jxx_Ch2_Out15
Wd m+2 (Output)	00	OUT0/Jxx_Ch3_Out00
	01	OUT1/Jxx_Ch3_Out01
	:	:
	14	OUT14/Jxx_Ch3_Out14
	15	OUT15/Jxx_Ch3_Out15
Wd m+3 (Output)	00	OUT0/Jxx_Ch4_Out00
	01	OUT1/Jxx_Ch4_Out01
	:	:
	14	OUT14/Jxx_Ch4_Out14
	15	OUT15/Jxx_Ch4_Out15

External Interface

8-point/16-point Units (18-point Terminal Blocks)

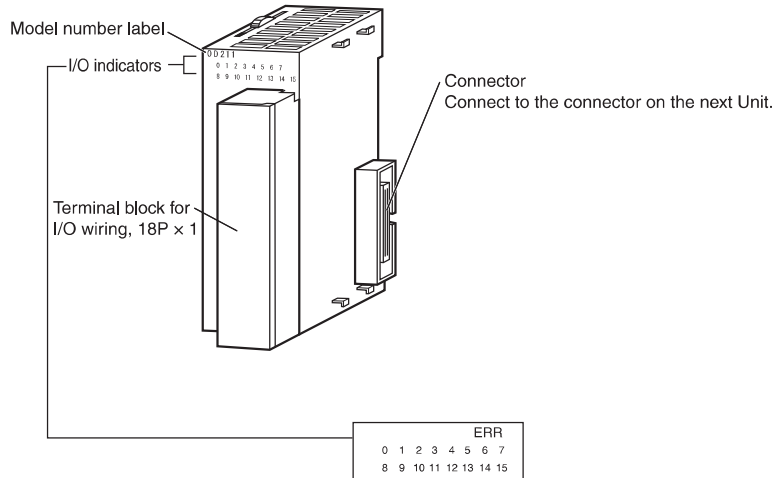

Note: The CJ1W-OD202, CJ1W-OD204, and CJ1W-OD212 also have an ERR indicator for the load short-circuit alarm.

32-point Units (Models with 40-point Fujitsu Connector or MIL Connector)

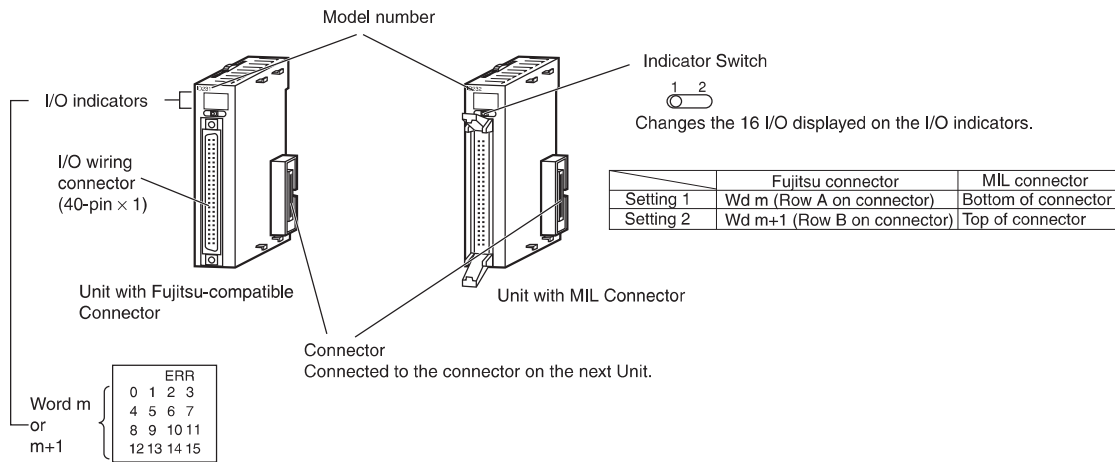

Note: Only the CJ1W-OD232 has an ERR indicator for the load short-circuit alarm.

64-point Units (Models with Two 40-point Fujitsu Connectors or MIL Connector)

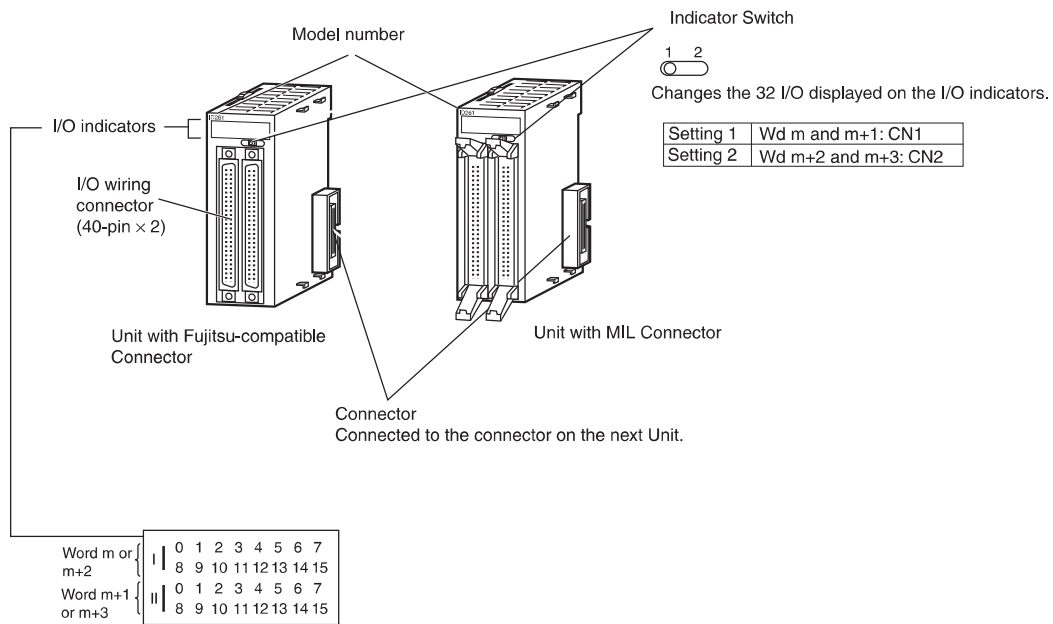

Wiring Basic I/O Units with Terminal Blocks

Electric Wires

The following wire gauges are recommended.

Terminal Block Connector	Wire Size
18-terminal	AWG 22 to 18 (0.32 to 0.82 mm ²)

Crimp terminals

Use crimp terminals (M3) having the dimensions shown below.



I/O Unit Wiring Methods

An I/O Unit can be connected to an external device by any of the following three methods.

1. User-provided Cable

An I/O Unit can be directly connected to an external device by using a connector.

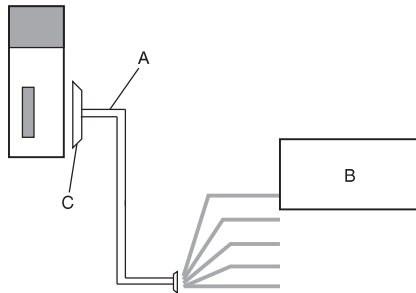

A	User-provided cable
B	External device
C	Connector

2. Connector-Terminal Block Conversion Unit

Use a Connecting Cable to connect to a Connector-Terminal Block Conversion Unit.

Converting the I/O Unit connector to a screw terminal block or push-in terminal block makes it easy to connect external devices.

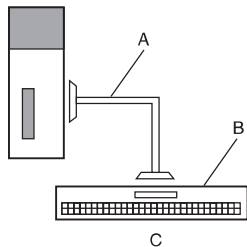

A	Connecting Cable for Connector-Terminal Block Conversion Unit XW2Z
B	Connector-Terminal Block Conversion Unit XW2R
C	Conversion to a screw terminal block

3. I/O Relay Terminal

Use a Connecting Cable to connect to an I/O Relay Terminal.

The I/O specifications can be converted to relay outputs and AC inputs by connecting the I/O Relay Terminal to an I/O Unit.

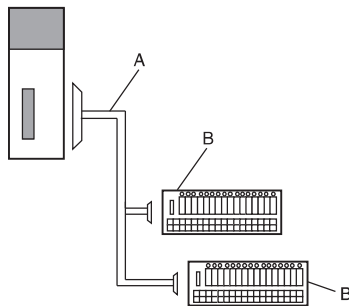

A	Connecting Cable for I/O Relay Terminals XW2Z-R
B	I/O Relay Terminals G70V, G7TC Relay Terminals G70D, G70R I/O Terminal Socket G70A Or, conversion to relay outputs and AC inputs.

1. Using User-made Cables with Connector

Available Connectors

Use the following connectors when assembling a connector and cable.

32- and 64-point Basic I/O Units with Fujitsu-compatible Connectors

Applicable Units

Model	Specifications	Pins
CJ1W-OD231	Transistor Output Unit with Sinking Outputs, 32 outputs	40
CJ1W-OD261	Transistor Output Unit with Sinking Outputs, 64 outputs	

Applicable Cable-side Connectors

Connection	Pins	OMRON set	Fujitsu parts
Solder-type	40	C500-CE404	Socket: FCN-361J040-AU Connector cover: FCN-360C040-J2
Crimped	40	C500-CE405	Socket: FCN-363J040 Connector cover: FCN-360C040-J2 Contacts: FCN-363J-AU
Pressure-welded	40	C500-CE403	FCN-367J040-AU/F

32- and 64-point Basic I/O Units with MIL Connectors

Applicable Units

Model	Specifications	Pins
CJ1W-OD232	Transistor Output Unit with sourcing outputs, 32 outputs	40
CJ1W-OD262	Transistor Output Unit with sourcing outputs, 64 outputs	
CJ1W-OD233 CJ1W-OD234	Transistor Output Unit with sinking outputs, 32 outputs	
CJ1W-OD263	Transistor Output Unit with sinking outputs, 64 outputs	

Applicable Cable-side Connectors

Connection	Pins	OMRON set	DDK parts
Pressure-welded	40	XG4M-4030-T *1	FRC5-A040-3T0S
	40	XG5N-401 *2	HU-40OS2-001
Crimped	–	Crimp Contacts for XG5N *3 XG5W-0232 (loose contacts: 100 pieces) XG5W-0232-R (reel contacts: 10,000 pieces)	HU-111S

*1. Socket and Stain Relief set.

*2. Crimp Contacts (XG5W-0232) are sold separately.

*3. Applicable wire size is AWG 28 to 24. For applicable conductor construction and more information, visit the OMRON website at www.ia.omron.com.

Wire Size

We recommend using cable with wire gauges of AWG 28 to 24 (0.08 to 0.2 mm²). Use cable with external wire diameters of 1.61 mm max.

Crimping Tools

The following models are recommended for crimping tools and pressure-welding tools for Fujitsu connectors.

Tools for Crimped Connectors (Fujitsu Component)

Product Name	Model
Hand Crimping Tool	FCN-363T-T005/H
Contact Withdrawal Tool	FCN-360T-T001/H

Tools for Pressure-welded Connectors (Fujitsu Component)

Product Name	Model
Hand Press	FCN-707T-T101/H
Cable Cutter	FCN-707T-T001/H
Locator Plate	FCN-367T-T012/H

The following models are recommended for tools for OMRON MIL connectors.

Tools for Pressure-welded Connectors (OMRON)

Product Name	Model
Pressure-welding Tool	XY2B-0002
Attachment	XY2B-1007

Tools for Crimped Connectors (OMRON)

Product Name	Model
Manual Crimping Tool	XY2B-7007

2. Connecting Connector-Terminal Block Conversion Units

Connection Patterns for Connector-Terminal Block Conversion Units

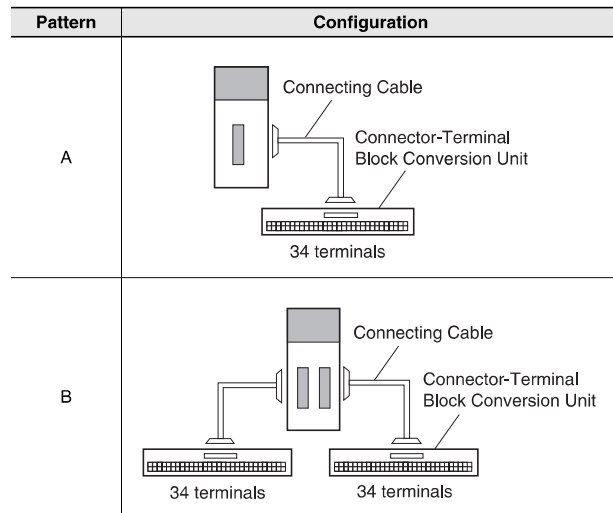

Combination of I/O Units with Connector-Terminal Block Conversion Units

Unit	I/O capacity	Number of connectors	Polarity	Connection pattern	Connecting Cable *	Connector-Terminal Block Conversion Unit	Wiring method	Common terminals
CJ1W-OD231	32 outputs	1 Fujitsu connector	NPN	A	XW2Z-□□□B	XW2R-J34G-C3	Phillips screw	No
						XW2R-E34G-C3	Slotted screw (rise up)	
						XW2R-P34G-C3	Push-in spring	
CJ1W-OD232	32 outputs	1 MIL connector	PNP	A	XW2Z-□□□K	XW2R-J34G-C4	Phillips screw	No
						XW2R-E34G-C4	Slotted screw (rise up)	
						XW2R-P34G-C4	Push-in spring	
CJ1W-OD233	32 outputs	1 MIL connector	NPN	A	XW2Z-□□□K	XW2R-J34G-C4	Phillips screw	No
						XW2R-E34G-C4	Slotted screw (rise up)	
						XW2R-P34G-C4	Push-in spring	
CJ1W-OD234	32 outputs	1 MIL connector	NPN	A	XW2Z-□□□K	XW2R-J34G-C4	Phillips screw	No
						XW2R-E34G-C4	Slotted screw (rise up)	
						XW2R-P34G-C4	Push-in spring	
CJ1W-OD261	64 outputs	2 Fujitsu connectors	NPN	B	XW2Z-□□□B (2 pcs)	XW2R-J34G-C3 (2 Units)	Phillips screw	No
						XW2R-E34G-C3 (2 Units)	Slotted screw (rise up)	
						XW2R-P34G-C3 (2 Units)	Push-in spring	
CJ1W-OD262	64 outputs	2 MIL connectors	PNP	B	XW2Z-□□□K (2 pcs)	XW2R-J34G-C4 (2 Units)	Phillips screw	No
						XW2R-E34G-C4 (2 Units)	Slotted screw (rise up)	
						XW2R-P34G-C4 (2 Units)	Push-in spring	
CJ1W-OD263	64 outputs	2 MIL connectors	NPN	B	XW2Z-□□□K (2 pcs)	XW2R-J34G-C4 (2 Units)	Phillips screw	No
						XW2R-E34G-C4 (2 Units)	Slotted screw (rise up)	
						XW2R-P34G-C4 (2 Units)	Push-in spring	

* The box □ is replaced by the cable length.

Note: For details, refer to the XW2R series catalog (Cat. No. G077).

3. Connecting I/O Relay Terminals

Connection Patterns for I/O Relay Terminals

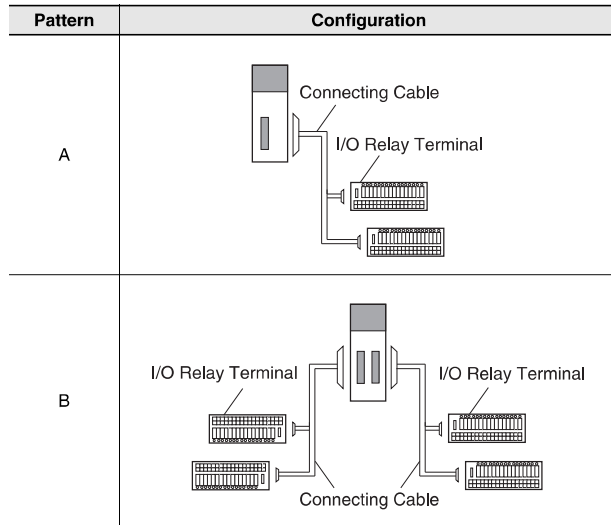

Combination of I/O Units with I/O Relay Terminals and Connecting Cables

Model	I/O Units			Connection pattern	Connecting Cables		I/O Relay Terminals			
	I/O capacity	External connectors	Polarity		Model *1	Quantity required	Model	I/O points	Quantity required	Wiring method
CJ1W-OD231	32 outputs	1 Fujitsu connector (40 p)	Sinking (NPN)	A	XW2Z-RO□C-□	1	G70V-SOC16P(-C4)	16	2	Screw terminal
							G7TC-OC16	16		
							G70D-SOC/FOM16	16		
							G70D-VSOC16/VFOM16	16		
							G70A-ZOC16-3 *3	16		
G70R-SOC08 *2	8									
CJ1W-OD232	32 outputs	1 MIL connector (40 p)	Sourcing (PNP)	A	XW2Z-RO□-□-D1	1	G70A-ZOC16-4 *3	16	2	Screw terminal
							G70D-SOC/FOM16-1	16		
							G7TC-OC16-1	16		
CJ1W-OD233	32 outputs	1 MIL connector (40 p)	Sinking (NPN)	A	XW2Z-RO□-□-D1	1	G70V-SOC16P(-C4)	16	2	Screw terminal
							G7TC-OC16	16		
CJ1W-OD234	32 outputs	1 MIL connector (40 p)	Sinking (NPN)	A	XW2Z-RO□C-□	1	G70V-SOC16P(-C4)	16	2	Screw terminal
							G7TC-OC16	16		
							G70D-SOC/FOM16	16		
							G70D-VSOC16/VFOM16	16		
							G70A-ZOC16-3 *3	16		
G70R-SOC08 *2	8									
CJ1W-OD261	64 outputs	2 Fujitsu connectors (40 p)	Sinking (NPN)	B	XW2Z-RO□C-□	2	G70V-SOC16P(-C4)	16	4	Screw terminal
							G7TC-OC16	16		
							G70D-SOC/FOM16	16		
							G70D-VSOC16/VFOM16	16		
							G70A-ZOC16-3 *3	16		
G70R-SOC08 *2	8									
CJ1W-OD262	64 outputs	2 MIL connectors (40 p)	Sourcing (PNP)	B	XW2Z-RO□-□-D1	2	G70V-SOC16P-1(-C4)	16	4	Screw terminal
							G70A-ZOC16-4 *3	16		
							G70D-SOC/FOM16-1	16		
CJ1W-OD263	64 outputs	2 MIL connectors (40 p)	Sinking (NPN)	B	XW2Z-RI□-□-D1	2	G7TC-OC16-1	16	4	Screw terminal
							G70V-SOC16P(-C4)	16		
CJ1W-OD263	64 outputs	2 MIL connectors (40 p)	Sinking (NPN)	B	XW2Z-RO□-□-D1	2	G7TC-OC16	16	4	Screw terminal
							G70D-SOC/FOM16	16		
							G70D-VSOC16/VFOM16	16		
							G70A-ZOC16-3 *3	16		
							G70R-SOC08 *2	8		

*1. The box □ is replaced by the cable length.

*2. In addition to the G70R-SOC08, 8-point output G7TC-OC08 and G70D-SOC08 models are available.

*3. The G70A-ZOC16-3/4 has I/O terminal sockets. Mounted relays are sold separately. In addition, an G70A-ZOC16-3/4 will be SPDT × 16 points with G2R relays.

Dimensions

(Unit: mm)

8-point/16-point Units (18-point Terminal Blocks)

CJ1W-OC201/ OC211/ OA201/ OD201 / OD202/ OD203/ OD204/ OD211/ OD213 / OD212

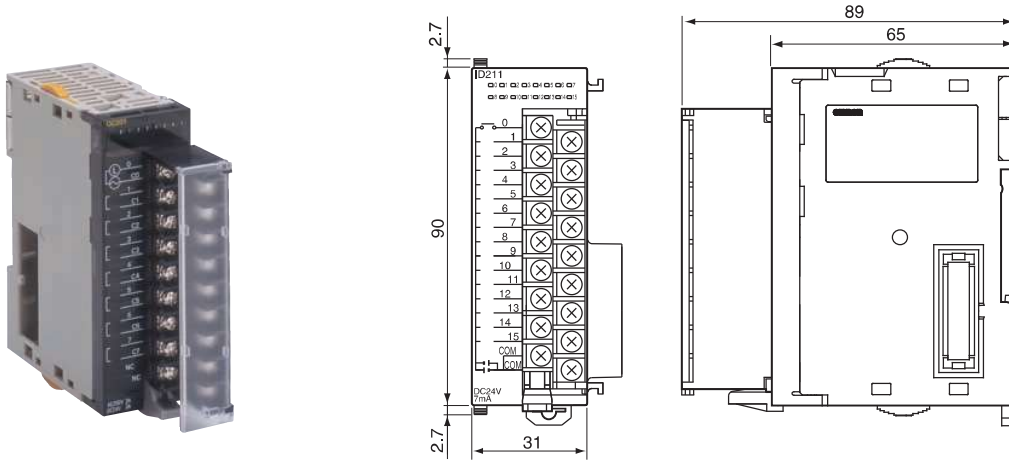

32-point Unit (Output Units)

With Fujitsu-Compatible Connector (40-pin × 1)

CJ1W-OD231

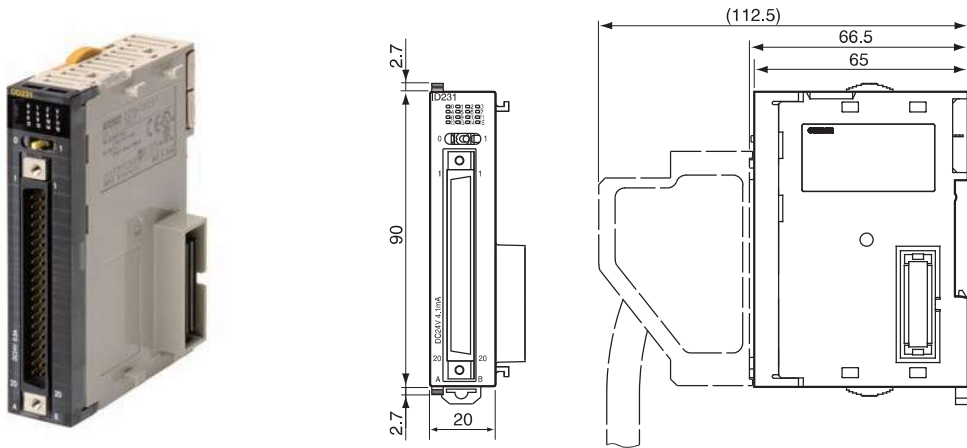

With MIL Connector (40-pin × 1)

CJ1W-OD232 / OD233 / OD234

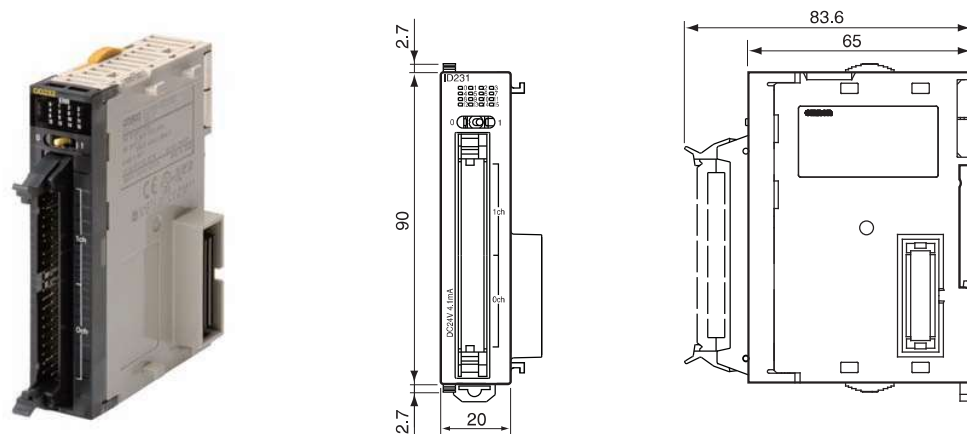

64-point Units (Output Units)

With Fujitsu-Compatible Connector (40-pin × 2)
CJ1W-OD261

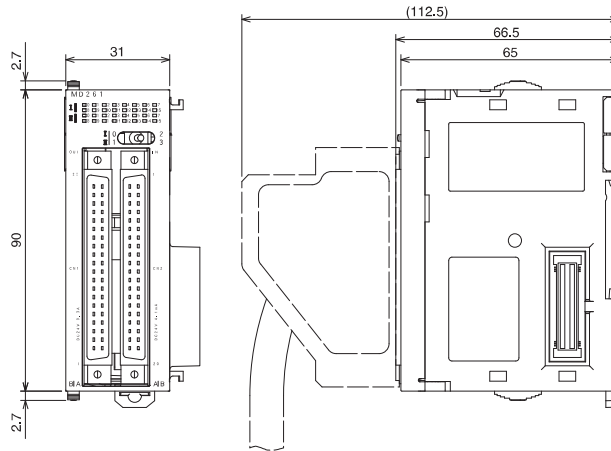

With MIL Connector (40-pin × 2)
CJ1W-OD262 / OD263

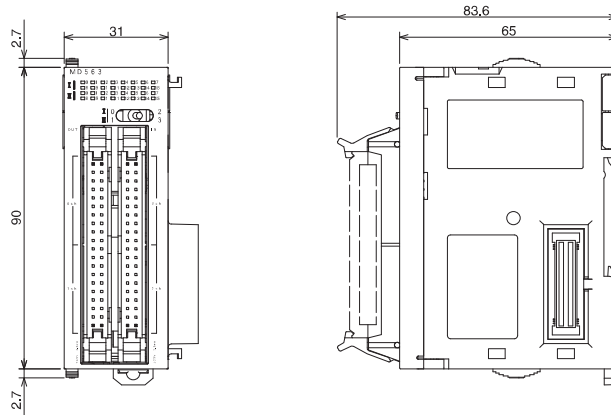

Related Manuals

Name	Cat. No.	Contents
CJ-series CJ2 CPU Unit Hardware User's Manual CJ2H-CPU6□-EIP CJ2H-CPU6□ CJ2M-CPU□□	W472	Describes the following for CJ2 CPU Units: <ul style="list-style-type: none"> • Overview and features • Basic system configuration • Part nomenclature and functions • Mounting and setting procedure • Remedies for errors • Also refer to the <i>Software User's Manual (W473)</i>.
CJ Series CJ1H-CPU□□H-R, CJ1G/H-CPU□□H, CJ1G-CPU□□P, CJ1G-CPU□□, CJ1M-CPU□□ Programmable Controllers Operation Manual	W393	Provides an outlines of and describes the design, installation, maintenance, and other basic operations for the CJ-series PLCs.
NJ-series CPU Unit Hardware User's Manual NJ501-□□□□	W500	An introduction to the entire NJ-series system is provided along with the following information on a Controller built with an NJ501 CPU Unit. <ul style="list-style-type: none"> • Features and system configuration • Introduction • Part names and functions • General specifications • Installation and wiring • Maintenance and inspection Use this manual together with the NJ-series CPU Unit Software User's Manual (Cat. No. W501).

Terms and Conditions Agreement

Read and understand this catalog.

Please read and understand this catalog before purchasing the products. Please consult your OMRON representative if you have any questions or comments.

Warranties.

(a) Exclusive Warranty. Omron's exclusive warranty is that the Products will be free from defects in materials and workmanship for a period of twelve months from the date of sale by Omron (or such other period expressed in writing by Omron). Omron disclaims all other warranties, express or implied.

(b) Limitations. OMRON MAKES NO WARRANTY OR REPRESENTATION, EXPRESS OR IMPLIED, ABOUT NON-INFRINGEMENT, MERCHANTABILITY OR FITNESS FOR A PARTICULAR PURPOSE OF THE PRODUCTS. BUYER ACKNOWLEDGES THAT IT ALONE HAS DETERMINED THAT THE PRODUCTS WILL SUITABLY MEET THE REQUIREMENTS OF THEIR INTENDED USE.

Omron further disclaims all warranties and responsibility of any type for claims or expenses based on infringement by the Products or otherwise of any intellectual property right. (c) Buyer Remedy. Omron's sole obligation hereunder shall be, at Omron's election, to (i) replace (in the form originally shipped with Buyer Product, or (ii) repair the non-complying Product, or (iii) repay or credit Buyer an amount equal to the purchase price of the non-complying Product; provided that in no event shall Omron be responsible for warranty, repair, indemnity or any other claims or expenses regarding the Products unless Omron's analysis confirms that the Products were properly handled, stored, installed and maintained and not subject to contamination, abuse, misuse or inappropriate modification. Return of any Products by Buyer must be approved in writing by Omron before shipment. Omron Companies shall not be liable for the suitability or unsuitability or the results from the use of Products in combination with any electrical or electronic components, circuits, system assemblies or any other materials or substances or environments. Any advice, recommendations or information given orally or in writing, are not to be construed as an amendment or addition to the above warranty.

See <http://www.omron.com/global/> or contact your Omron representative for published information.

Limitation on Liability; Etc.

OMRON COMPANIES SHALL NOT BE LIABLE FOR SPECIAL, INDIRECT, INCIDENTAL, OR CONSEQUENTIAL DAMAGES, LOSS OF PROFITS OR PRODUCTION OR COMMERCIAL LOSS IN ANY WAY CONNECTED WITH THE PRODUCTS, WHETHER SUCH CLAIM IS BASED IN CONTRACT, WARRANTY, NEGLIGENCE OR STRICT LIABILITY.

Further, in no event shall liability of Omron Companies exceed the individual price of the Product on which liability is asserted.

Suitability of Use.

Omron Companies shall not be responsible for conformity with any standards, codes or regulations which apply to the combination of the Product in the Buyer's application or use of the Product. At Buyer's request, Omron will provide applicable third party certification documents identifying ratings and limitations of use which apply to the Product. This information by itself is not sufficient for a complete determination of the suitability of the Product in combination with the end product, machine, system, or other application or use. Buyer shall be solely responsible for determining appropriateness of the particular Product with respect to Buyer's application, product or system. Buyer shall take application responsibility in all cases.

NEVER USE THE PRODUCT FOR AN APPLICATION INVOLVING SERIOUS RISK TO LIFE OR PROPERTY OR IN LARGE QUANTITIES WITHOUT ENSURING THAT THE SYSTEM AS A WHOLE HAS BEEN DESIGNED TO ADDRESS THE RISKS, AND THAT THE OMRON PRODUCT(S) IS PROPERLY RATED AND INSTALLED FOR THE INTENDED USE WITHIN THE OVERALL EQUIPMENT OR SYSTEM.

Programmable Products.

Omron Companies shall not be responsible for the user's programming of a programmable Product, or any consequence thereof.

Performance Data.

Data presented in Omron Company websites, catalogs and other materials is provided as a guide for the user in determining suitability and does not constitute a warranty. It may represent the result of Omron's test conditions, and the user must correlate it to actual application requirements. Actual performance is subject to the Omron's Warranty and Limitations of Liability.

Change in Specifications.

Product specifications and accessories may be changed at any time based on improvements and other reasons. It is our practice to change part numbers when published ratings or features are changed, or when significant construction changes are made. However, some specifications of the Product may be changed without any notice. When in doubt, special part numbers may be assigned to fix or establish key specifications for your application. Please consult with your Omron's representative at any time to confirm actual specifications of purchased Product.

Errors and Omissions.

Information presented by Omron Companies has been checked and is believed to be accurate; however, no responsibility is assumed for clerical, typographical or proofreading errors or omissions.