

Safety Standard ISO 13849-1 Certified^{*2} (Corresponding to Categories 2 to 4)

3-Port Solenoid Valve/ Residual Pressure Release Valve with Detection of Main Valve Position



RoHS

*2 Refer to page 2 for certified products.

With main valve position detection function

Category 2

The main valve position detection function is used to detect inconsistencies between input signals and valve operations.

Residual pressure release valve

Safety limit switch



Body ported
VP542-X536

New



Base mounted
VP544-X536

With easy-to-construct redundant system

Categories 3 and 4

When the dual residual pressure release valve is used, if one of the valves fails to operate, the other one releases the residual pressure.

Dual Residual Pressure Release Valve VP544-X538

Residual pressure release valve ②

Residual pressure release valve ①

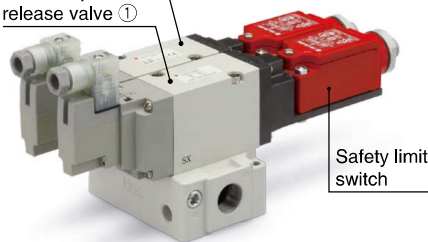

Safety limit switch

With Soft Start-up Function VP544-X555

Residual pressure release valve ②

Residual pressure release valve ①

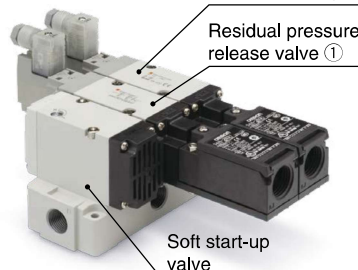

Soft start-up valve

Dual Residual Pressure Release Valve VG342-X87



Redundant System

A system in which even if one part fails, the system as a whole will still fulfill its required function. This is usually achieved through the incorporation of dual channels of operation such as dual valves, dual wiring, dual guard switches, etc.

VP/VG Series

CAT.ES11-111B

3-Port Solenoid Valve/ Residual Pressure Release Valve with Detection of Main Valve Position *VP/VG Series*

With main valve position detection function (Category 2)

Category 2 The safety function only requires the use of a single channel and is automatically checked.

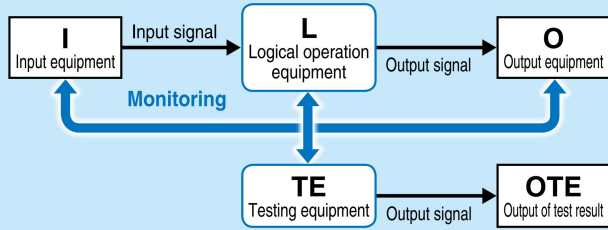

The main valve position detection function is used to detect inconsistencies between input signals and valve operations.

Input equipment (I): Detection equipment (sensor) of starting event
 Logical operation equipment (L): Relay sequence circuit, PLC control program
 Output equipment (O): Solenoid valve, Electromagnetic switch, Output relay
 Recommended valve: VP54□/74□-X536



VP542-X536

* This product is to be used as a component of a safety system; the safety of the equipment as a whole cannot be guaranteed by this single unit alone.

With easy-to-construct redundant system (Categories 3 and 4)

Category 3 The redundancy prevents the loss of the safety function when a single failure occurs. The safety function must be checked before each use. An accumulation of undetected faults can cause the loss of the safety function.

Category 4 The redundancy prevents the loss of the safety function when a single failure occurs. The safety function must be checked before each use. An accumulation of undetected faults does not affect the safety function. (Features a higher DC and MTTFd than Category 3)

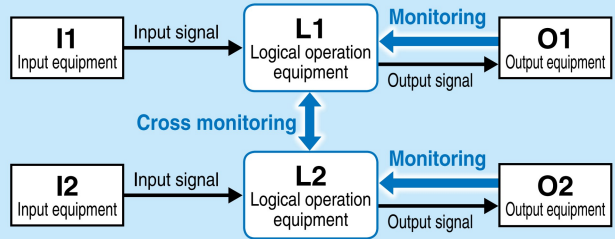

When the dual residual pressure release valve is used, if one of the valves fails to operate, the other one releases the residual pressure.

Input equipment (I1, I2): Detection equipment (sensor) of starting event
 Logical operation equipment (L1, L2): Relay sequence circuit, PLC control program
 Output equipment (O1, O2): Solenoid valve, Electromagnetic switch, Output relay
 Recommended valve: VP544/744-X538, VG342-X87

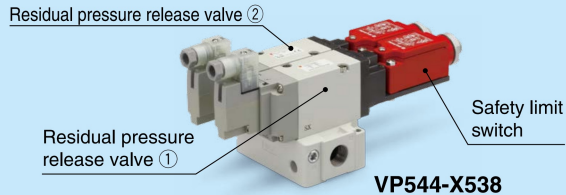

VP544-X538

Highly reliable construction

① The main valve position is detected by relaying the main valve's movements directly to the reed safety limit switch via the rod.

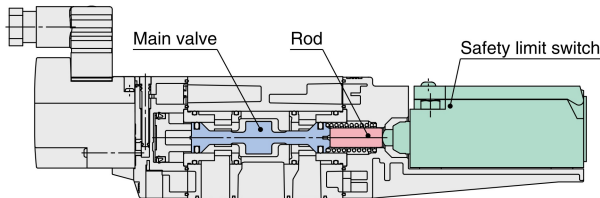

- ② Long service life: B_{10D}: 10 million cycles*1
- ③ The return spring ensures the release of residual pressure regardless of the pressure level.

*1 For the VP500/700, the safety limit switch made by OMRON

A variety of safety limit switches can be selected.



Made by OMRON



Made by Rockwell Automation

Conduit (VP series only) and M12 connector (4 pin) types are available. An M12 connector type with 6 pins is available.

With soft start-up function (-X555)

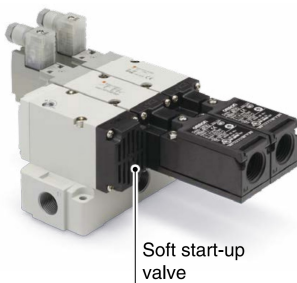

VP544-X555

- A function to gradually increase the initial pressure of the pneumatic system has been added to the dual residual pressure release valve.
- Fixed orifice and variable throttle are available as throttle options for adjusting the pressure increase. (ø1, ø1.5, ø2)

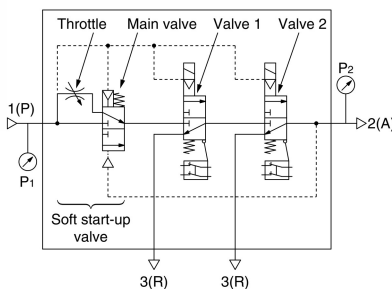

Output Pressure (P₂) vs Time Graph

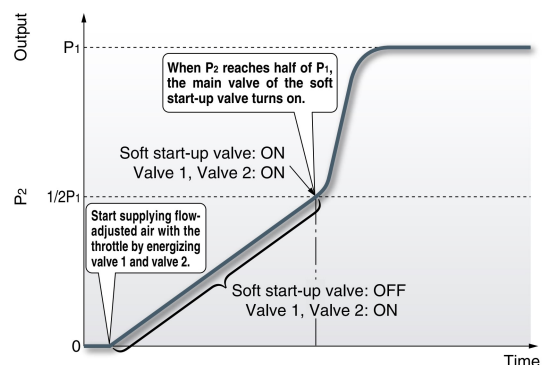

Standards and Enclosure

Model	Category	Safety limit switch manufacturer	Standards						
			Machinery directive	2006/42/EC		CE	cUL		RoHS
			Harmonized standards	EN ISO 13849-1:2015 EN ISO 13849-2:2012	EN ISO 4414:2010		Body ported	Base mounted	
Residual Pressure Release Valve VP54□/74□-X536 IP65 Page 3	2	OMRON Corporation		●	●	●	●	●	●
		Rockwell Automation, Inc.		●	●	●	●	●	●
Dual Residual Pressure Release Valve VP544/744-X538 IP65 Page 3	3, 4	OMRON Corporation		●	●	●	●	●	●
		Rockwell Automation, Inc.		●	●	●	●	●	●
Dual Residual Pressure Release Valve with Soft Start-up Function VP544/744-X555 IP65 Page 4	3, 4	OMRON Corporation		●	●	●	●	●	●
		Rockwell Automation, Inc.		●	●	●	●	●	●
Dual Residual Pressure Release Valve VG342-X87 IP40 Page 23	3, 4	OMRON Corporation		●	●	●	●	●	●
		Rockwell Automation, Inc.		●	●	●	●	●	●

Series Variations

Model	Category	Port size	Thread	Flow-rate characteristics C [dm ³ /(s·bar)] 1→2 (P→A)				
				5	10	15	20	25
Residual Pressure Release Valve VP54□-X536	2	3/8	Rc, G, NPT	8.9*1				
Residual Pressure Release Valve VP74□-X536		1/2	Rc, G, NPT	15.1*1				
Dual Residual Pressure Release Valve VP544-X538	3, 4	3/8	Rc, G, NPT	6.5				
Dual Residual Pressure Release Valve VP744-X538		1/2	Rc, G, NPT	10.3				
Dual Residual Pressure Release Valve with Soft Start-up Function VP544-X555	3, 4	3/8	Rc, G, NPT	5.2				
Dual Residual Pressure Release Valve with Soft Start-up Function VP744-X555		1/2	Rc, G, NPT	9.8				
Dual Residual Pressure Release Valve VG342-X87	3, 4	3/4	Rc, G, NPT	26.6				

*1 For the body-ported type

For details on Safety Standard ISO 13849-1, refer to Guide to Products Conforming to International Standards on the SMC website.

Can be connected to modular type F.R.L. units Page 20

Applicable models*1

- VP544/744-X536
- VP544/744-X538
- VP544/744-X555

*1 Please contact SMC for the VP542/742-X536.

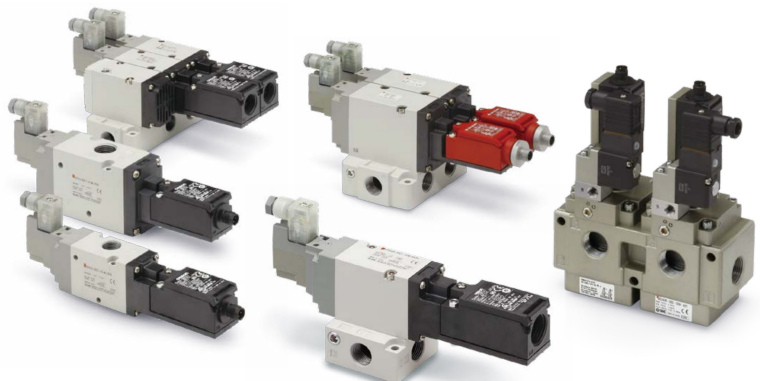
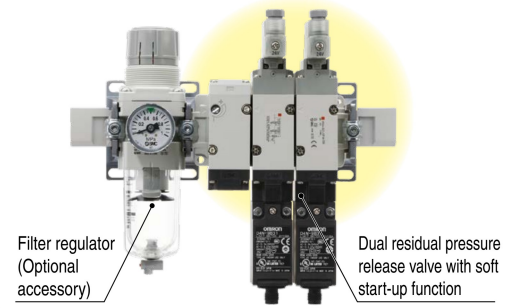

3-Port Solenoid Valve/ Residual Pressure Release Valve with Detection of Main Valve Position

VP500/700-X536, X538, X555



How to Order

Residual Pressure Release Valve

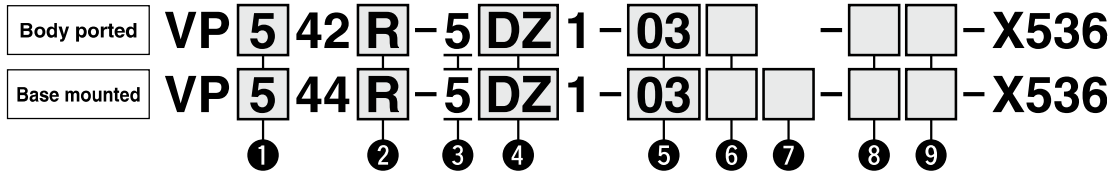

① Series

5	VP500
7	VP700

② Pilot

Nil	Internal pilot
R	External pilot

③ Voltage

5	24 VDC
---	--------

④ Electrical entry

DZ	DIN terminal, With light/surge voltage suppressor
YZ	DIN (EN 175301-803) terminal, With light/surge voltage suppressor

* Refer to Installation on page 22 before selecting the internal pilot type.

* Refer to page 22 for details on Y type.

⑤ Port size

Symbol	Port size	VP500	VP700
03	3/8	●	—
04	1/2	—	●

⑦ Bracket for modular connection (Modular adapter)

		VP544	VP744
Nil	None		
M	Yes		
M1	Yes	●	—

⑧ Safety limit switch/ Wiring

Nil	G1/2 (Made by OMRON)
M	M12 connector (Made by OMRON)
S1	M12 connector (Made by Rockwell Automation)

⑨ With check valve (Only external pilot)

Symbol	Check valve	Applicable tube O.D.	Thread		
			Rc	G	NPT
Nil	None	—	●	●	●
A	Yes	ø6	—	—	—
B		ø1/4"	—	—	●

* For the internal pilot, the symbol is nil.
* Refer to Piping for External Pilot Type on page 5 for selection of the check valve.

⑥ Thread

Nil	Rc
F	G
N	NPT

Part Nos./With Modular Adapter

Applicable model	Ordering symbol	Combinable modular adapter part no.	Applicable spacer
VP544□-5□1-03	M	E310-U03	Y300-A, Y300T-A
VP544□-5□1-03	M1	E410-U03	Y400-A, Y400T-A
VP744□-5□1-04	M	E410-U04	Y400-A, Y400T-A

Dual Residual Pressure Release Valve

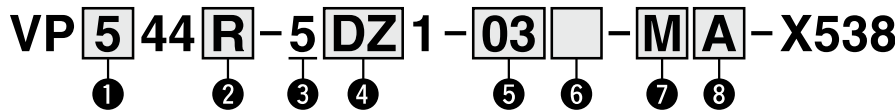

① Series

5	VP500
7	VP700

② Pilot

Nil	Internal pilot
R	External pilot

③ Voltage

5	24 VDC
---	--------

④ Electrical entry

DZ	DIN terminal, With light/surge voltage suppressor
YZ	DIN (EN 175301-803) terminal, With light/surge voltage suppressor

* Refer to Installation on page 22 before selecting the internal pilot type.

* Refer to page 22 for details on Y type.

⑤ Port size

Symbol	Port size	VP500	VP700
03	3/8	●	—
04	1/2	—	●

⑥ Thread

Nil	Rc
F	G
N	NPT

⑦ Safety limit switch/ Wiring

Nil	G1/2 (Made by OMRON)
M	M12 connector (Made by OMRON)
S1	M12 connector (Made by Rockwell Automation)

⑧ With check valve (Only external pilot)

Symbol	Check valve	Applicable tube O.D.	Thread		
			Rc	G	NPT
Nil	None	—	●	●	●
A	Yes	ø6	—	—	—
B		ø1/4"	—	—	●

* For the internal pilot, the symbol is nil.
* Refer to Piping for External Pilot Type on page 5 for selection of the check valve.

How to Order

Dual Residual Pressure Release Valve with Soft Start-up Function



VP **5** **44** **□** - **5** **DZ** **1** - **03** **□** - **M** **□** **□** - X555

①
②
③
④
⑤
⑥
⑦
⑧
⑨

① Series

5	VP500
7	VP700

② Pilot

Nil	Internal pilot
R	External pilot

* Refer to Installation on page 22 before selecting the internal pilot type.

③ Voltage

5	24 VDC
---	--------

④ Electrical entry

DZ	DIN terminal, With light/surge voltage suppressor
YZ	DIN (EN 175301-803) terminal, With light/surge voltage suppressor

* Refer to page 22 for details on Y type.

⑤ Port size

Symbol	Port size	VP500	VP700
03	3/8	●	—
04	1/2	—	●

⑥ Thread

Nil	Rc
F	G
N	NPT

⑦ Safety limit switch/Wiring

Nil	G1/2 (Made by OMRON)
M	M12 connector (Made by OMRON)
S1	M12 connector (Made by Rockwell Automation)

⑧ With check valve (Only external pilot)

Symbol	Check valve	Applicable tube O.D.	Thread		
			Rc	G	NPT
Nil	None	—	●	●	●
A	Yes	ø6	●	—	—
B		ø1/4"	—	—	●

* For the internal pilot, the symbol is nil.

* Refer to Piping for External Pilot Type on page 5 for selection of the check valve.

⑨ Throttle

Nil	Variable throttle
10	ø1 fixed orifice
15	ø1.5 fixed orifice
20*1	ø2 fixed orifice

*1 VP700 only

Made to Order

1 Series Compatible with Secondary Batteries

For details on 25A-, refer to the **Web Catalog** "Series Compatible with Secondary Batteries/25A- Series."

How to Order

25A-VP **□** **4** **□** **□** - **5** **DZ** **1** - **□** **□** **□** - **□** **□** **□** - X536
 X538
 X555

● Fill in according to How to Order above.
 ● Secondary battery compatible

* Electrical entry can be selected only for D type. Check valve type is available only when the thread type is Rc.

* There are no settings for the bracket for modular connection for the 25A-VP500/700-X536.

VP500/700

Symbols

X536

X538

X555

Optional Accessories

Specific Product Precautions

VG342

Symbols

X87

Specific Product Precautions

VP500/700-X536, X538, X555

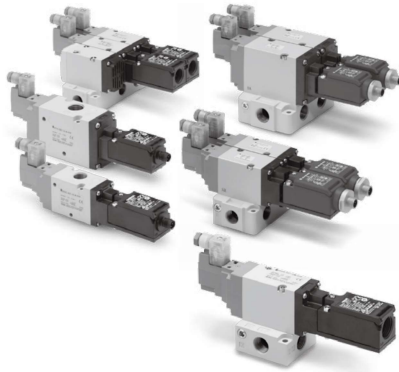

Valve Specifications

Fluid	Air	
Type of actuation	N.C. (Spring return)	
Operation	Internal pilot	External pilot
Operating pressure range	0.25 to 0.7 MPa	0.25 to 0.7 MPa
External pilot pressure	—	0.25 to 0.7 MPa (Same as operating pressure)
Maximum operating frequency	30 cycles/minute	
Minimum operating frequency	1 cycle/week	
Operating and ambient temperatures	-10 to 50°C (No freezing)	
Ambient humidity	20 to 90% RH (No condensation)	
Manual override	None	
Pilot exhaust	Individual exhaust	
Lubrication	Not required	
Mounting orientation	Unrestricted	
Impact/Vibration resistance	150/30 m/s ²	
Enclosure	IP65	
Operating environment	Indoors	
B _{10D} (MTTFd calculation)	10,000,000 cycles	

Internal Pilot Type

⚠ Caution

Even when the inlet pressure is within the operating pressure range, restricted piping, etc., may cause reduced flow on the inlet side, leading to the valve not operating properly. Refer to Installation in the Specific Product Precautions for details.

Piping for External Pilot Type

⚠ Caution

The product may not operate when the external pilot pressure is insufficient due to simultaneous operation or restricted air piping. In this case, use the check valve (AKH series) with the external pilot port, change the piping size or adjust the set pressure to provide a constant pressure of 0.25 MPa or more.

Flow-rate Characteristics / Weight

Model	Flow-rate characteristics						Weight [g]	
	1→2 (P→A)			2→3 (A→R)			M	S1
	C [dm ³ /(s·bar)]	b	Cv	C [dm ³ /(s·bar)]	b	Cv		
VP542-X536	8.9	0.16	2.2	8.9	0.20	2.1	330	350
VP544-X536	8.8	0.07	2.0	8.8	0.13	2.0	460	480
VP742-X536	15.1	0.21	3.6	15.3	0.22	3.7	570	590
VP744-X536	14.7	0.05	3.3	15.0	0.17	3.4	790	810
VP544-X538	6.5	0.08	1.3	6.7	0.10	1.3	920	960
VP744-X538	10.3	0.08	2.3	9.7	0.08	2.1	1520	1560
VP544-X555	5.2	0.06	1.1	6.7	0.10	1.3	1300	1340
VP744-X555	9.8	0.08	2.1	9.7	0.08	2.1	2180	2220

Needle Valve / Flow-rate Characteristics (VP544/744-X555)

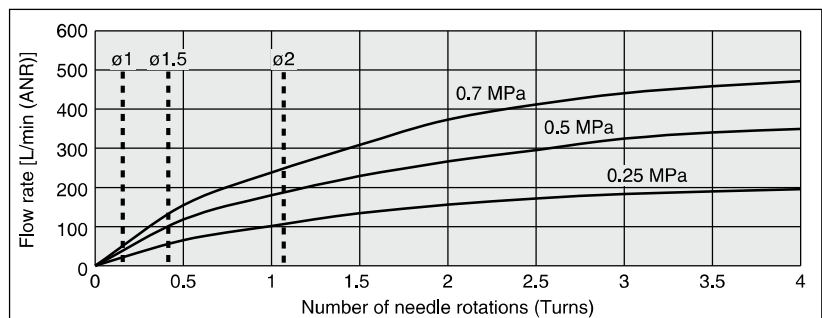

Solenoid Specifications

Electrical entry	DIN terminal
Rated voltage	24 VDC
Allowable voltage fluctuation	±10%
Power consumption	0.45 W
Surge voltage suppressor	Varistor
Indicator	LED

Safety Limit Switch Specifications

Manufacturer	OMRON	Rockwell Automation
Electrical wiring	G1/2, M12 connector	M12 connector
Contact resistance	25 mΩ or less	50 mΩ or less
Min. applicable load	5 VDC, 1 mA (Load resistance)	5 VDC, 5 mA (Load resistance)
Max. voltage	24 VDC	
Max. load current	50 mA	
Max. load inductance	0.5 H	
Insulation voltage	300 V	600 V
Protection against electric shock	Class II (EN 60947-5-1:2004)	

Symbols

Safety limit switch
Made by OMRON

Symbol

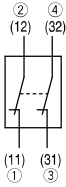

Terminal/Pin Numbers (Built-in switch 2 N.C.)

M12 connector pin number	Wiring specification
①	
②	
③	
④	

G1/2 terminal number	Wiring specification
(11)	
(12)	
(31)	
(32)	

Recommended Crimped Terminals

Manufacturer	Type	Wiring size
J.S.T. Mfg. Co., Ltd.	FV0.5-3.7 (F type) V0.5-3.7 (Straight type)	AWG20 (0.5 mm ²)

J.S.T. Mfg. Co., Ltd. is a Japanese manufacturer.

VP54□(R)/74□(R)-X536

Internal pilot

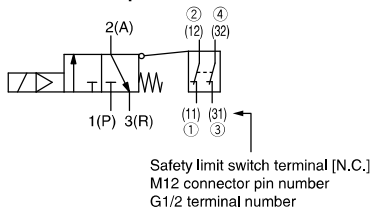

External pilot

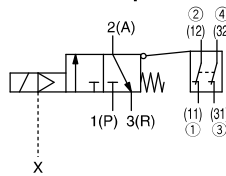

External pilot/With check valve

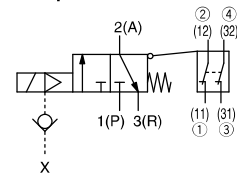

VP544(R)/744(R)-X538

Internal pilot

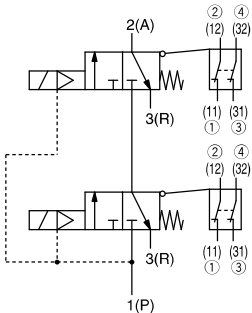

External pilot

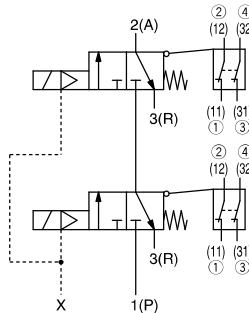

External pilot/With check valve

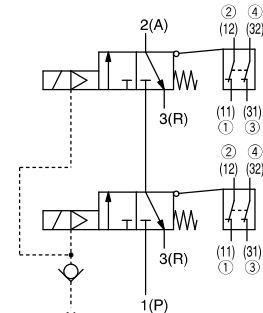

VP544(R)/744(R)-X555

Internal pilot

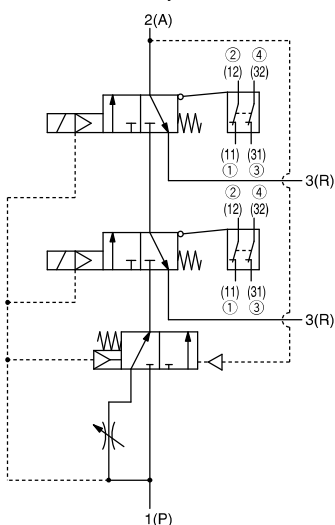

External pilot

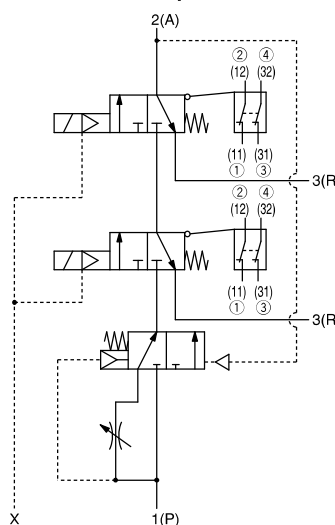

External pilot/With check valve

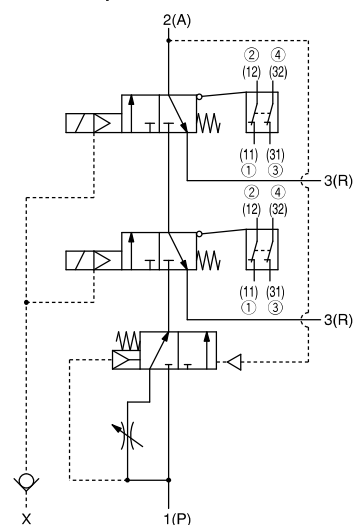

VP500/700
Symbols
X536
X538
X555
Optional Accessories
Specific Product Precautions
VG342
Symbols
X87
Specific Product Precautions

VP500/700-X536, X538, X555

Symbols

Safety limit switch
Made by
Rockwell Automation

Symbol

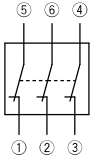

Pin Numbers (Built-in switch 3 N.C.)

M12 connector pin number	Wiring specification
①	
⑤	
②	
⑥	
③	
④	

VP54□(R)/74□(R)-X536

Internal pilot

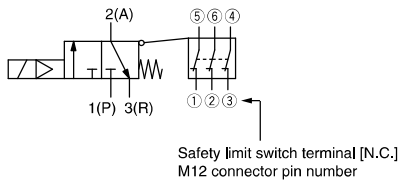

External pilot

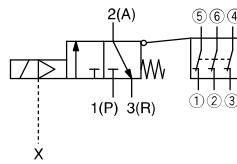

External pilot/With check valve

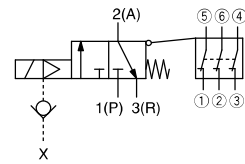

VP544(R)/744(R)-X538

Internal pilot

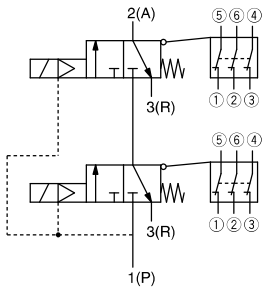

External pilot

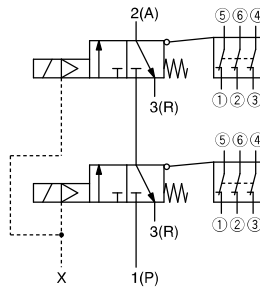

External pilot/With check valve

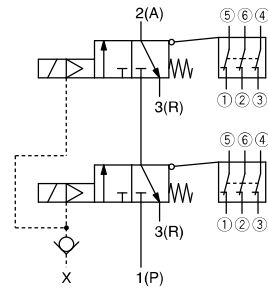

VP544(R)/744(R)-X555

Internal pilot

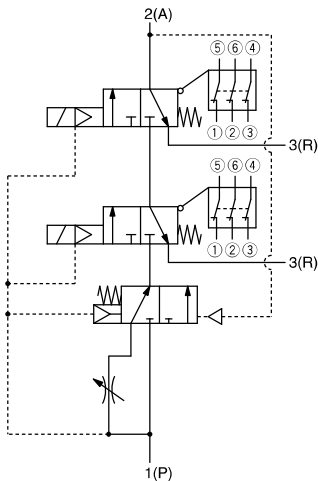

External pilot

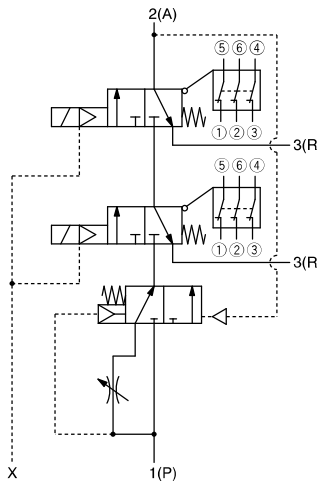

External pilot/With check valve

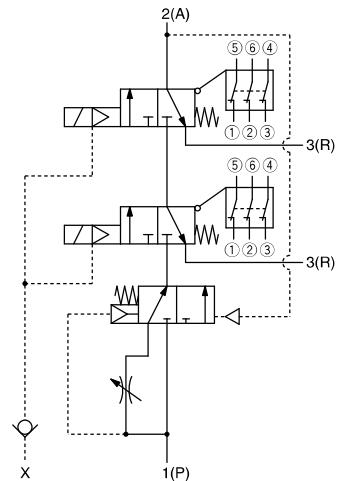

Dimensions

Residual Pressure Release Valve (-X536)

VP542(R)-5^D_VZ1-03□-□-X536

VP542(R)-5^D_VZ1-03□-M□-X536

Safety limit switch
Made by OMRON

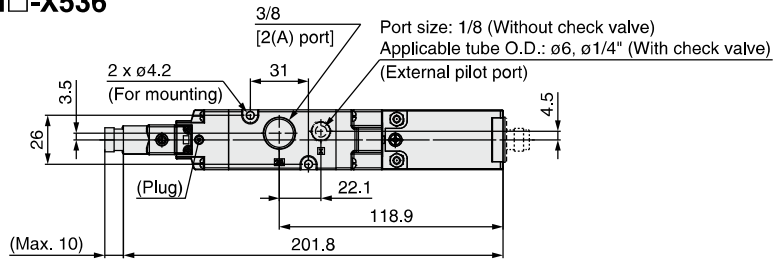

Applicable cable O.D.
ø3.5 to ø7

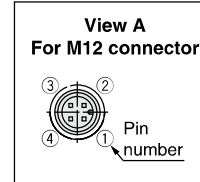
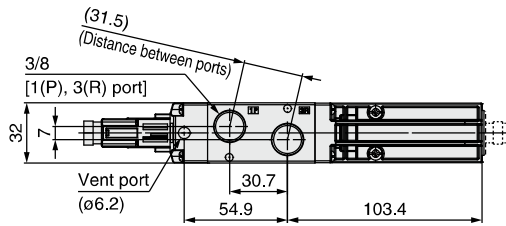
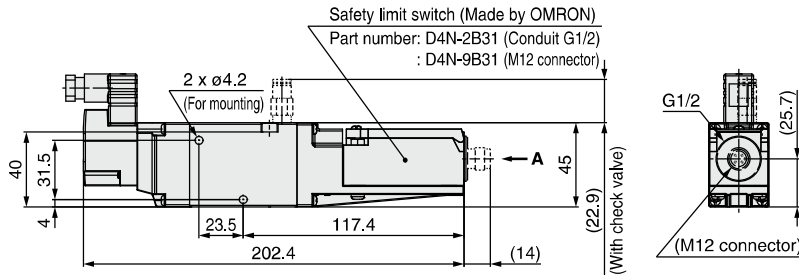
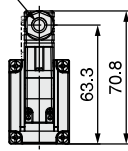

VP544(R)-5^D_VZ1-03□□-□□-X536

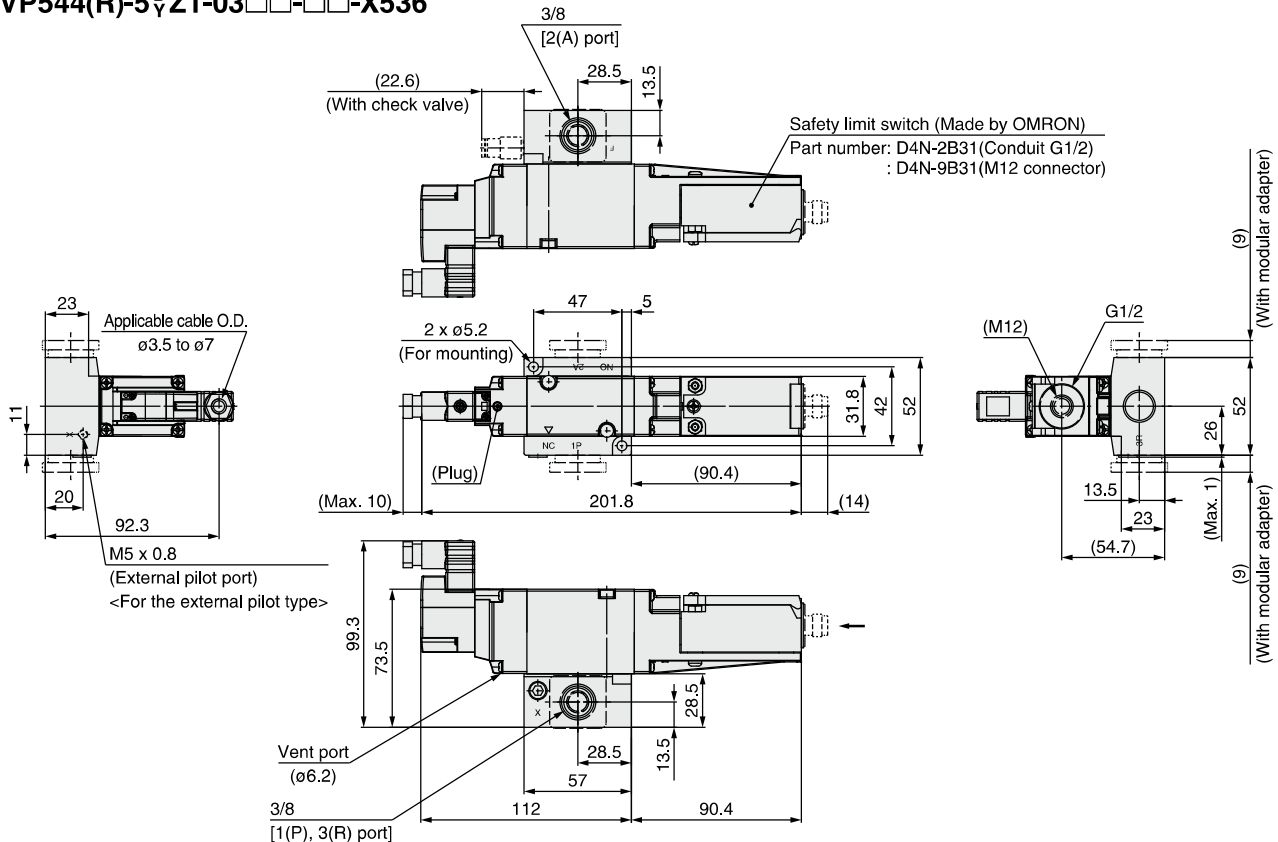

VP500/700

Symbols

X536

X538

X555

Optional Accessories

Specific Product Precautions

VG342

Symbols

X87

Specific Product Precautions

VP500/700-X536

Dimensions

Residual Pressure Release Valve (-X536)

VP542(R)-5^D_VZ1-03□-S1□-X536

Safety limit switch
Made by
Rockwell Automation

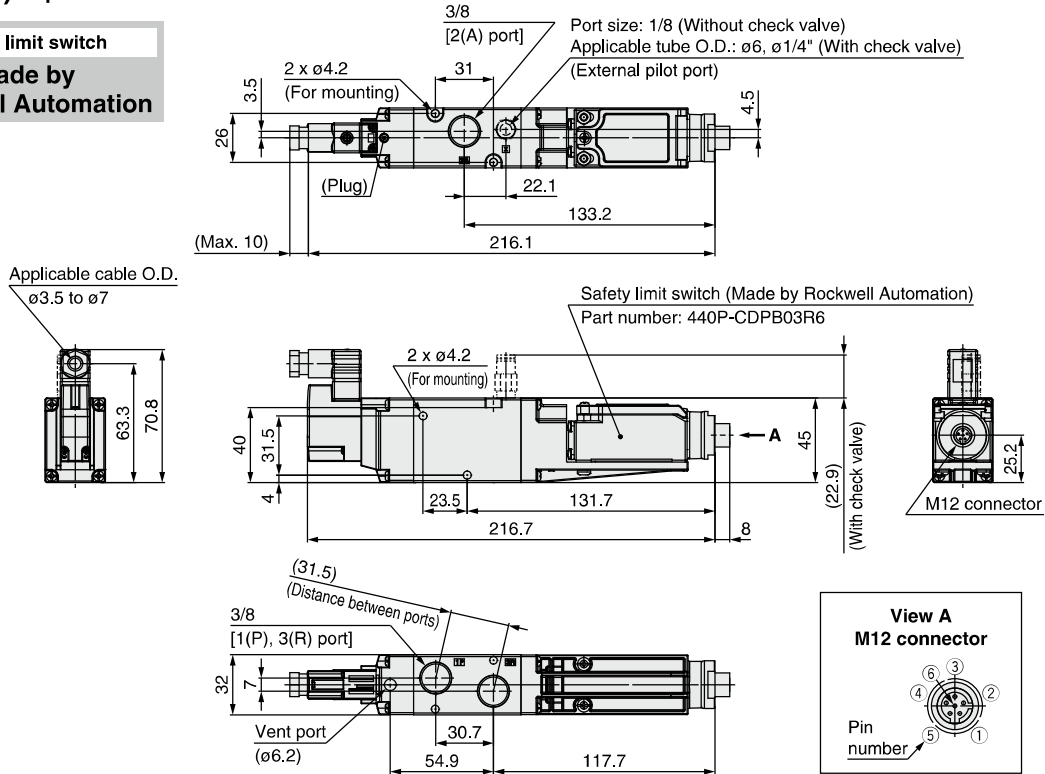

VP544(R)-5^D_VZ1-03□□-S1□-X536

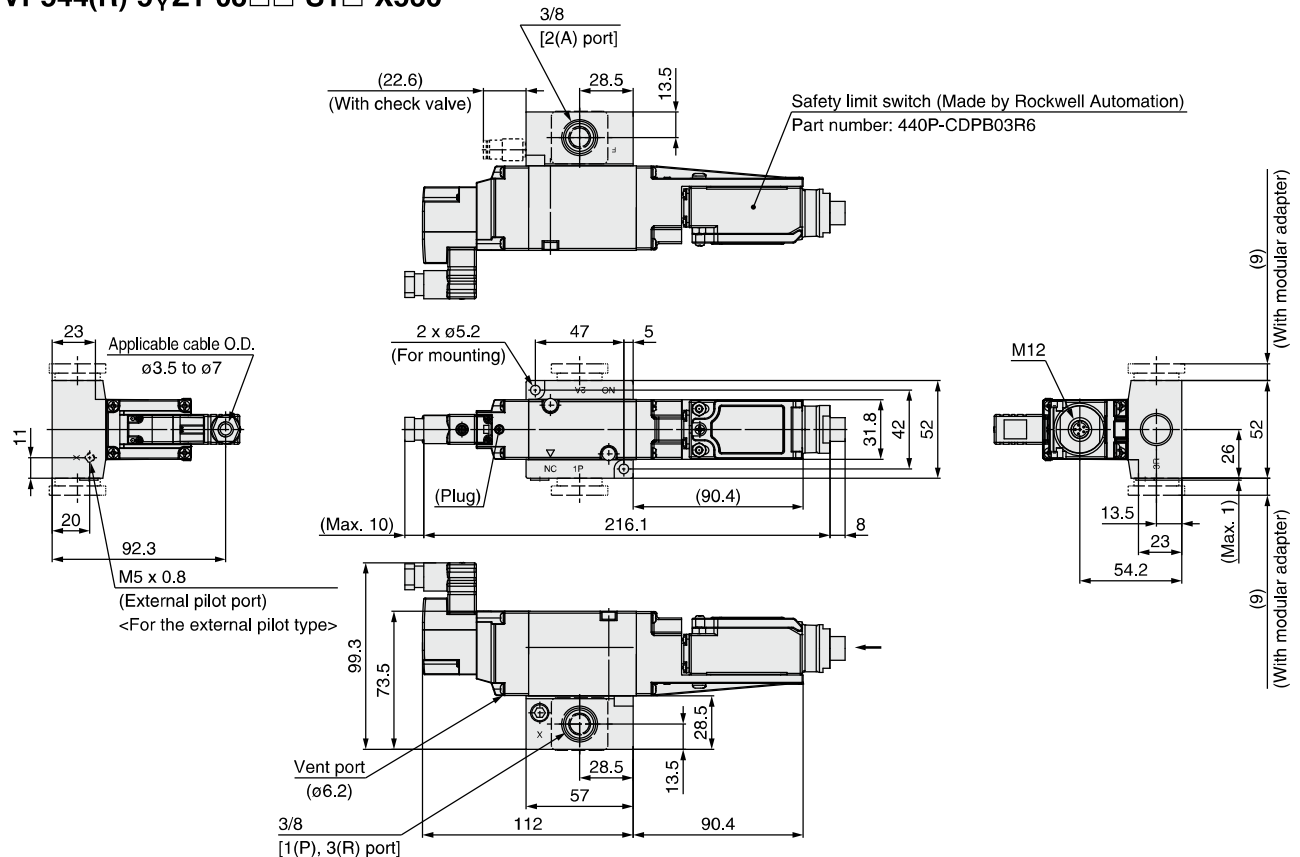

Dimensions

Residual Pressure Release Valve (-X536)

VP742(R)-5_YZ1-04□-□-X536
VP742(R)-5_YZ1-04□-M□-X536

Safety limit switch
Made by OMRON

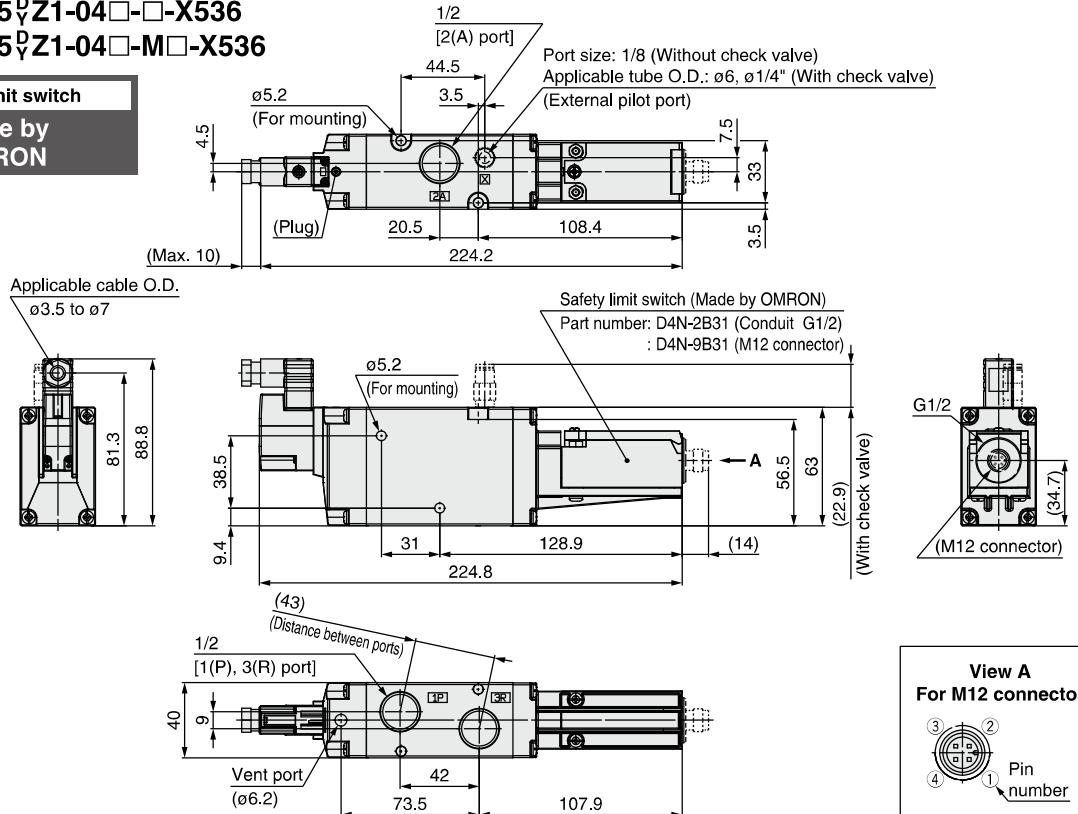

VP744(R)-5_YZ1-04□□-□□-X536

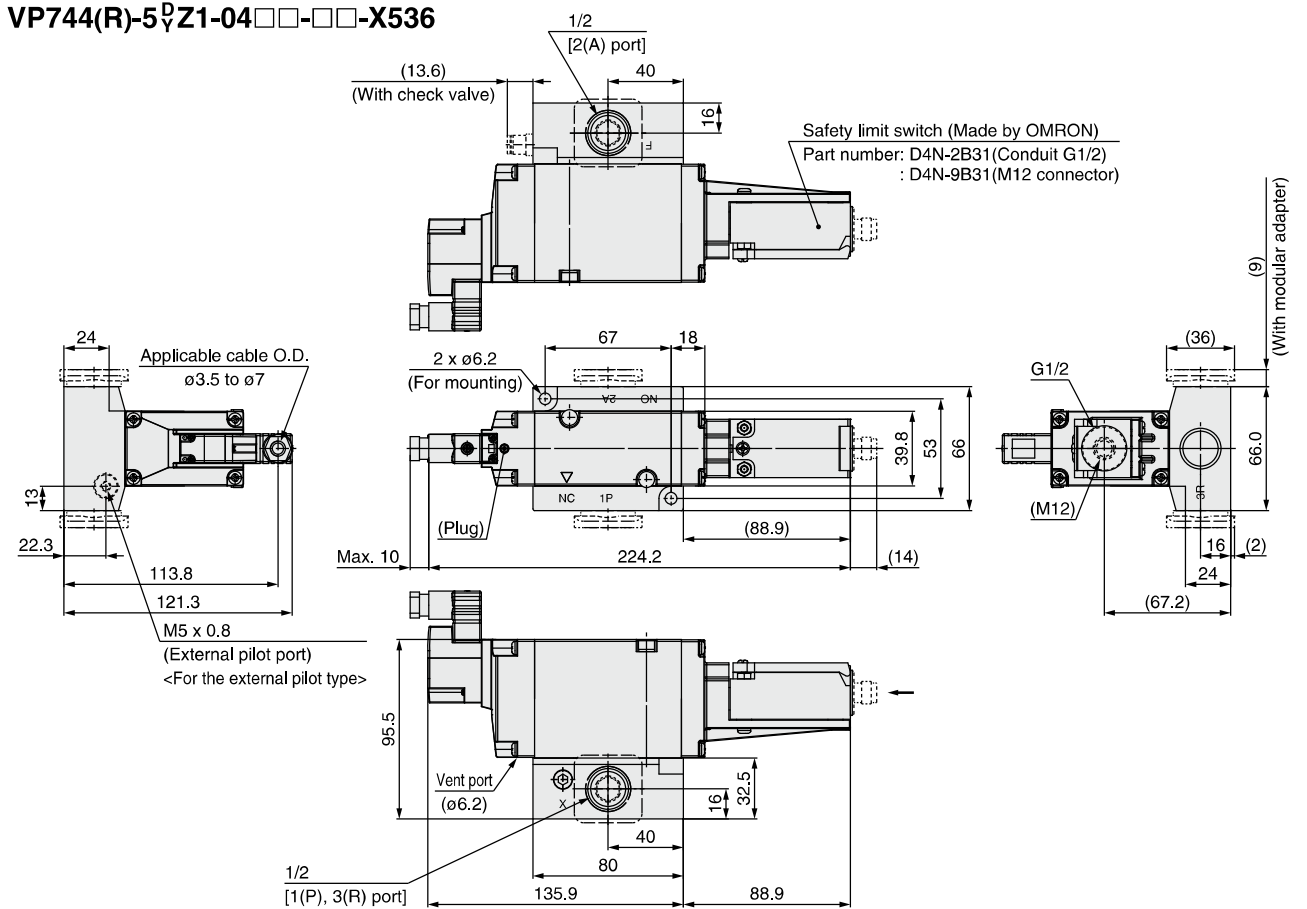

VP500/700

Symbols

X536

X538

X555

Optional Accessories

Specific Product Precautions

VG342

Symbols

X87

Specific Product Precautions

VP500/700-X536

Dimensions

Residual Pressure Release Valve (-X536)

VP742(R)-5 \overline{D} Z1-04□-S1□-X536

Safety limit switch
Made by
Rockwell Automation

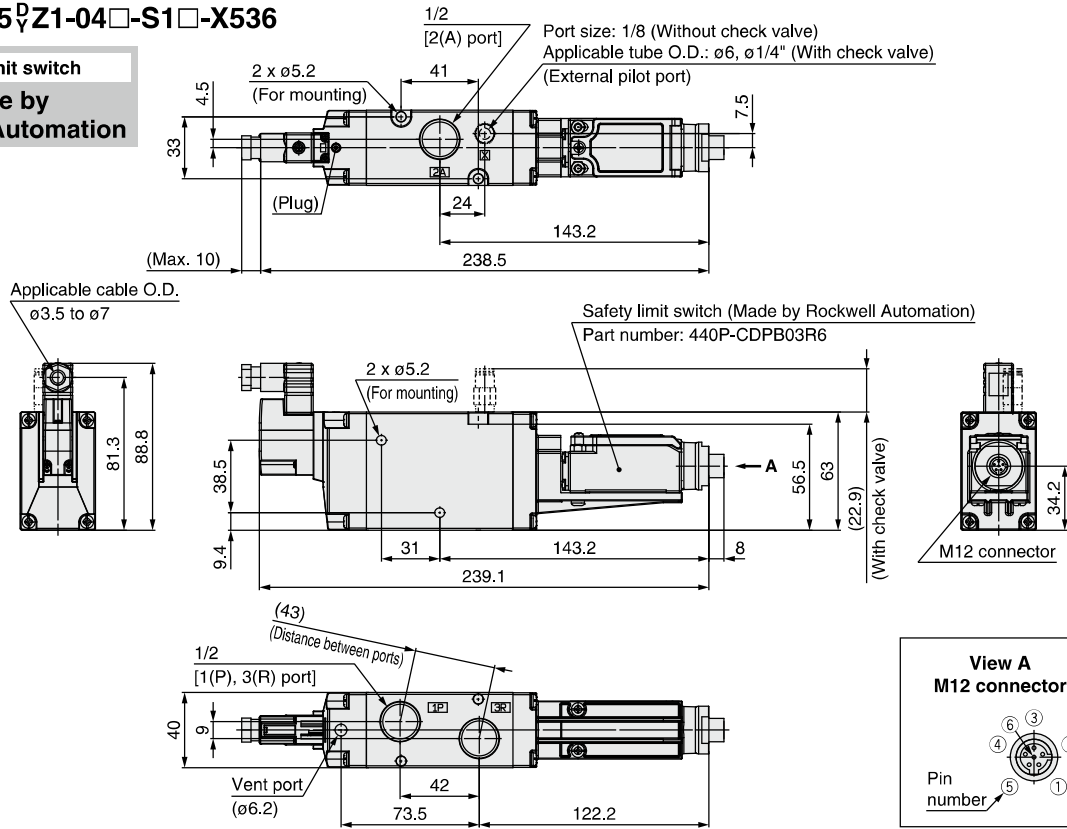

VP744(R)-5 \overline{D} Z1-04□□-S1□-X536

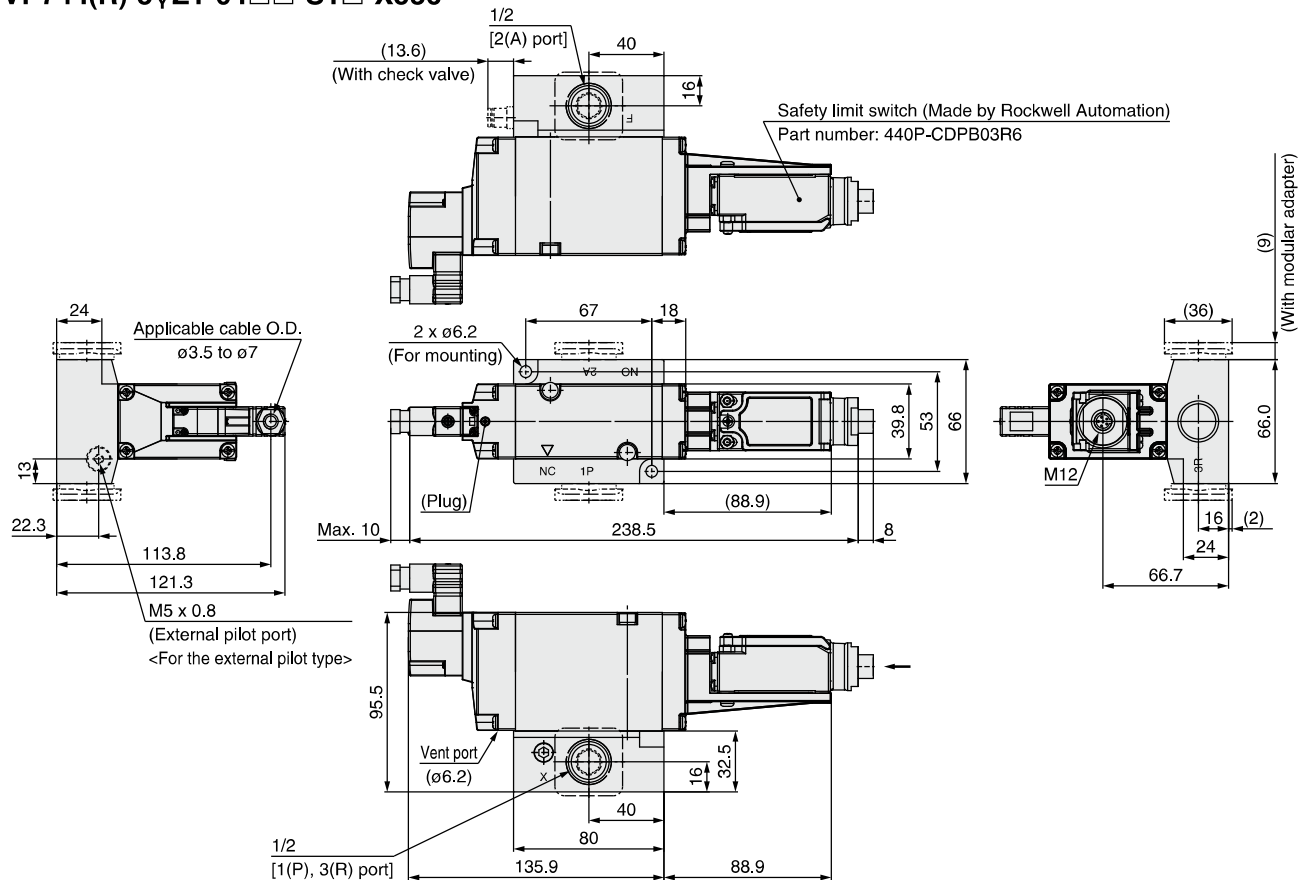

Dimensions

Dual Residual Pressure Release Valve (-X538)

VP544(R)-5^DZ1-03□-□-X538

VP544(R)-5^DZ1-03□-M□-X538

Safety limit switch
Made by OMRON

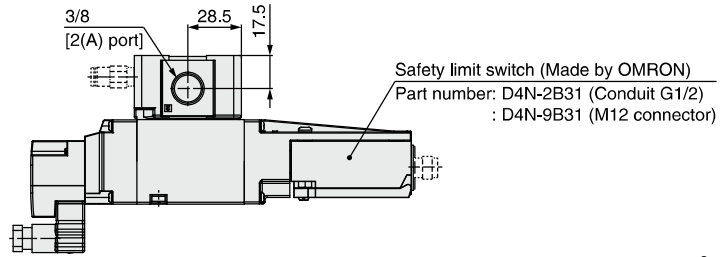

Port size: 1/8 (Without check valve)
Applicable tube O.D.: $\phi 6$, $\phi 1/4$ " (With check valve)
(External pilot port)

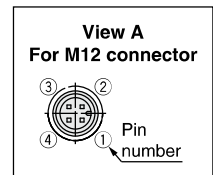
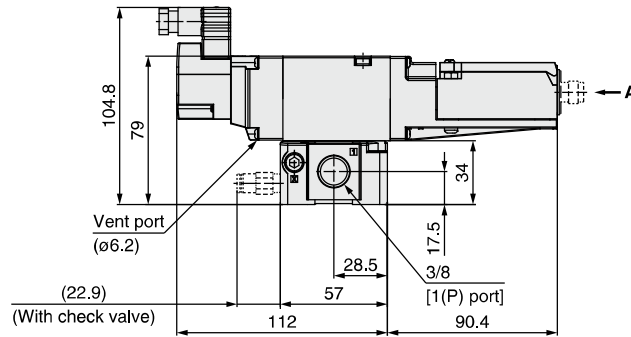
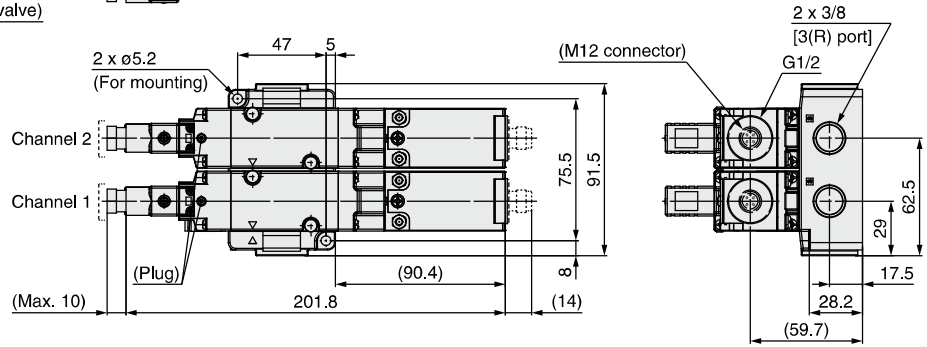
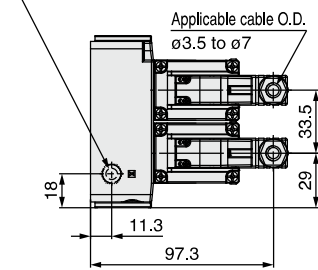

VP500/700

Symbols

X536

X538

X555

Optional Accessories

Specific Product Precautions

VG342

Symbols

X87

Specific Product Precautions

VP500/700-X538

Dimensions

Dual Residual Pressure Release Valve (-X538)

VP544(R)-5^DZ1-03□-S1□-X538

Safety limit switch
**Made by
 Rockwell Automation**

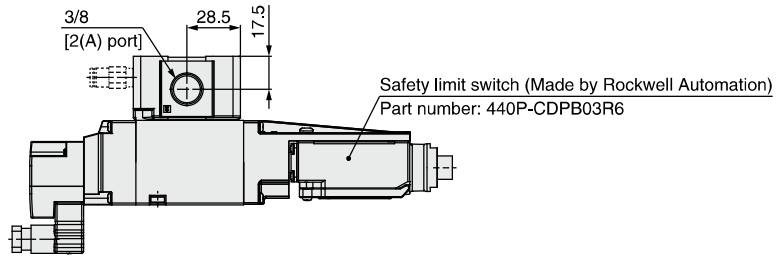

Port size: 1/8 (Without check valve)
 Applicable tube O.D.: $\phi 6$, $\phi 1/4$ " (With check valve)
 (External pilot port)

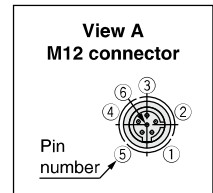
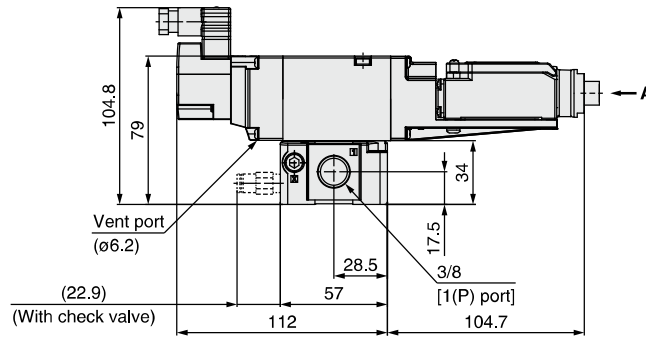
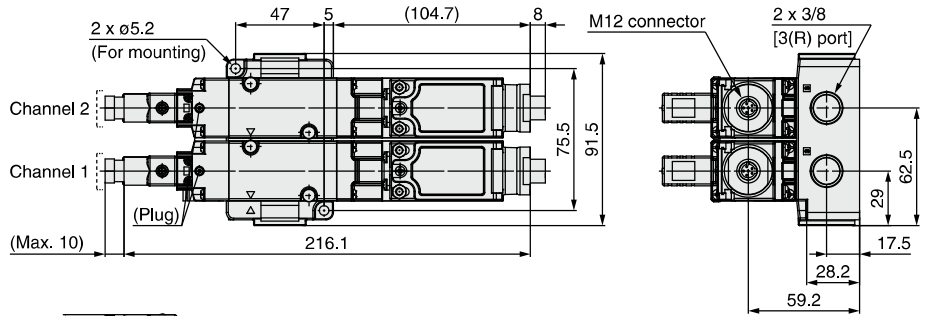
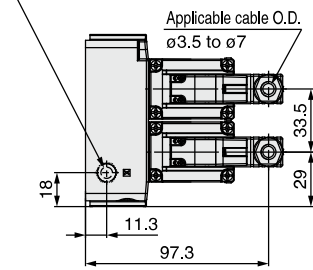

Dimensions

Dual Residual Pressure Release Valve (-X538)

VP744(R)-5^D_VZ1-04□-□-X538

VP744(R)-5^D_VZ1-04□-M□-X538

Safety limit switch
Made by
OMRON

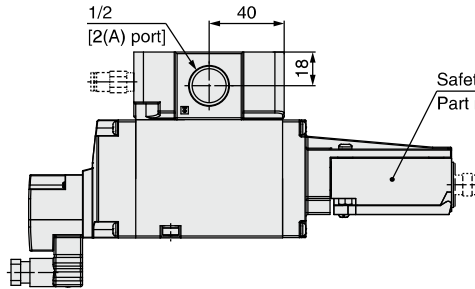

Safety limit switch (Made by OMRON)
Part number: D4N-2B31 (Conduit G1/2)
: D4N-9B31 (M12 connector)

Port size: 1/8 (Without check valve)
Applicable tube O.D.: ø6, ø1/4" (With check valve)
(External pilot port)

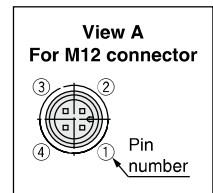
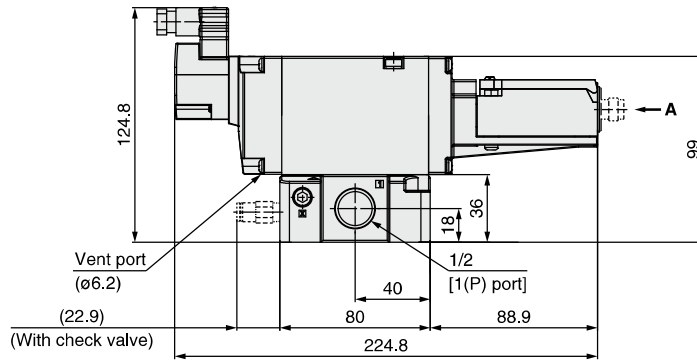
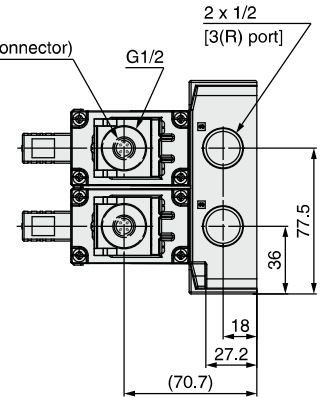
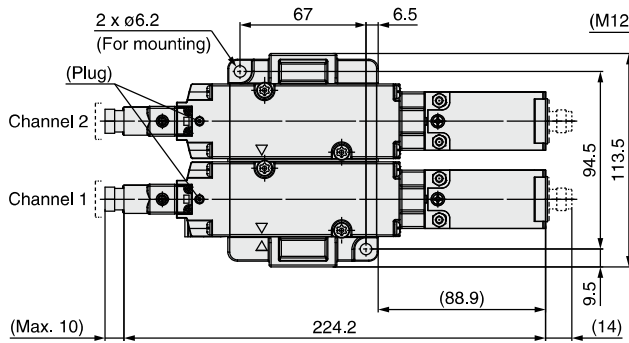
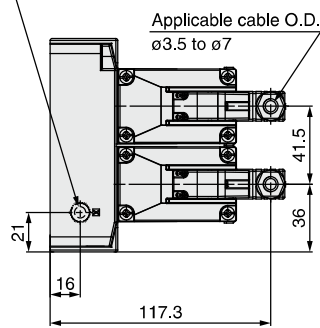

VP500/700

Symbols

X536

X538

X555

Optional Accessories

Specific Product Precautions

VG342

Symbols

X87

Specific Product Precautions

VP500/700-X538

Dimensions

Dual Residual Pressure Release Valve (-X538)

VP744(R)-5^DZ1-04□-S1□-X538

Safety limit switch
**Made by
 Rockwell Automation**

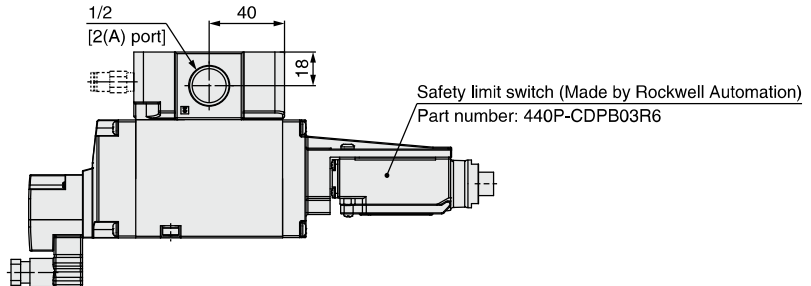

Port size: 1/8 (Without check valve)
 Applicable tube O.D.: $\phi 6$, $\phi 1/4$ " (With check valve)
 (External pilot port)

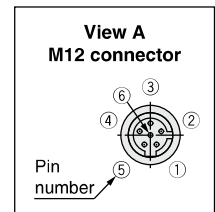
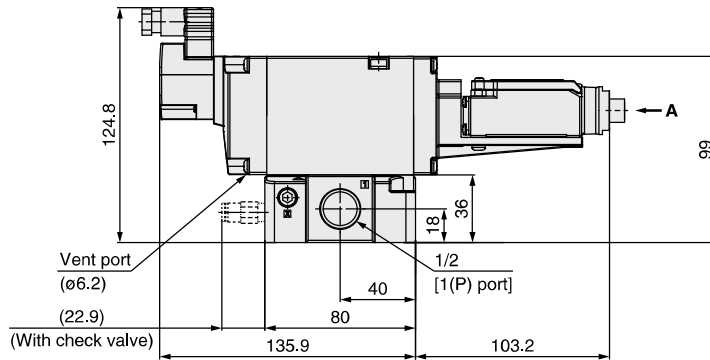
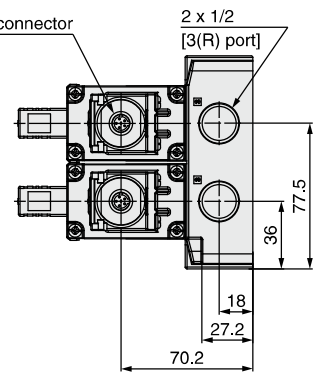
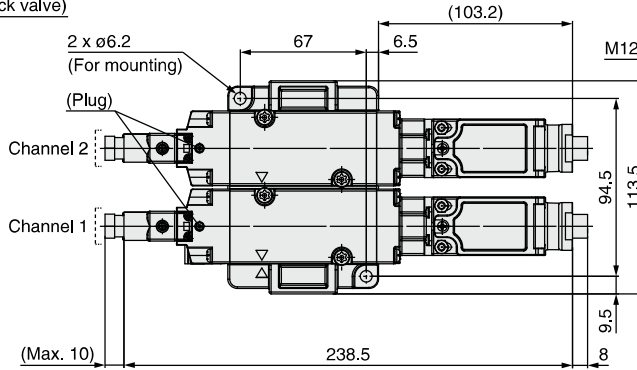
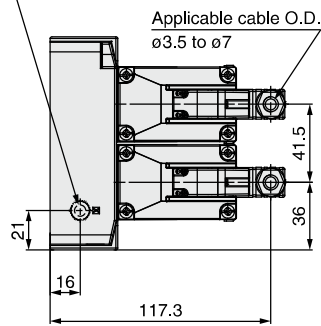

Dimensions

Dual Residual Pressure Release Valve with Soft Start-up Function (-X555)

VP544(R)-5^DZ1-03□-□□-X555

VP544(R)-5^DZ1-03□-M□□-X555

Safety limit switch
Made by OMRON

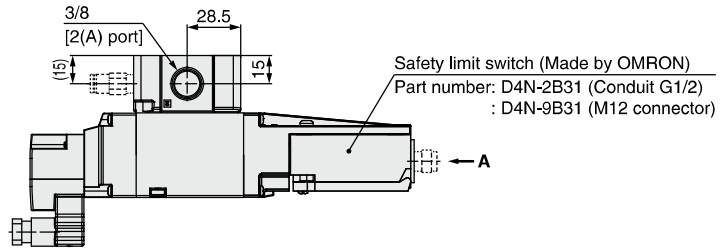

Port size: 1/8 (Without check valve)
Applicable tube O.D.: $\phi 6$, $\phi 1/4$ " (With check valve)
(External pilot port)

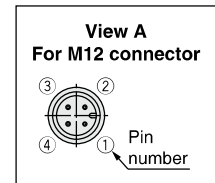
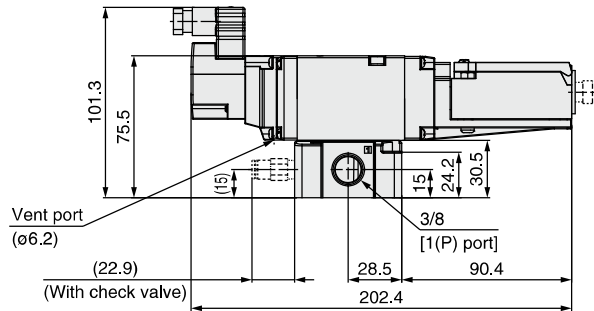
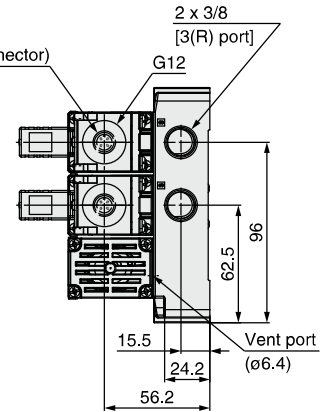
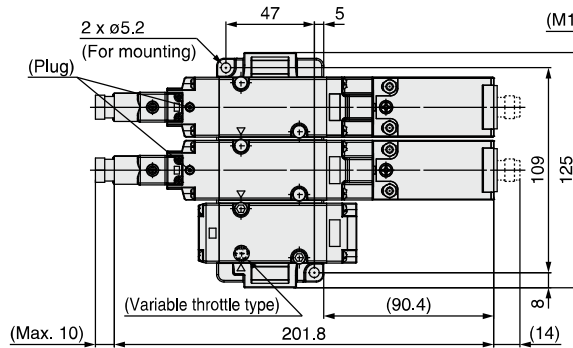
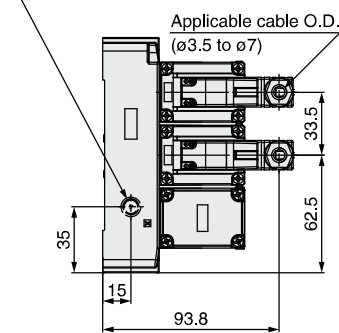

VP500/700

Symbols

X536

X538

X555

Optional Accessories

Specific Product Precautions

VG342

Symbols

X87

Specific Product Precautions

VP500/700-X555

Dimensions

Dual Residual Pressure Release Valve with Soft Start-up Function (-X555)

VP544(R)-5^DZ1-03□-S1□□-X555

Safety limit switch
Made by
Rockwell Automation

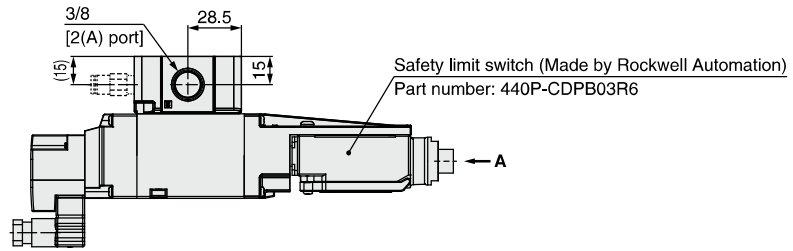

Port size: 1/8 (Without check valve)
 Applicable tube O.D.: $\phi 6$, $\phi 1/4"$ (With check valve)
 (External pilot port)

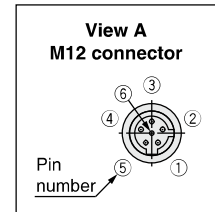
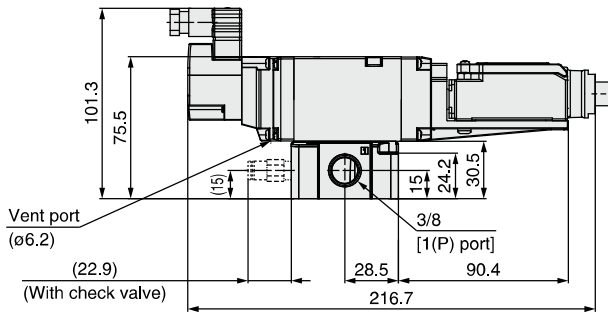
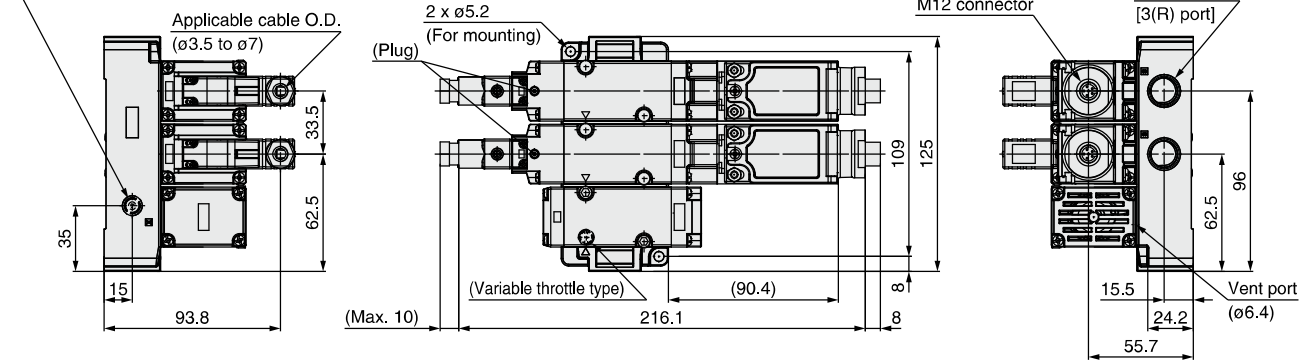

Dimensions

Dual Residual Pressure Release Valve with Soft Start-up Function (-X555)

VP744(R)-5^DZ1-04□-□□-X555

VP744(R)-5^DZ1-04□-M□□-X555

Safety limit switch
Made by OMRON

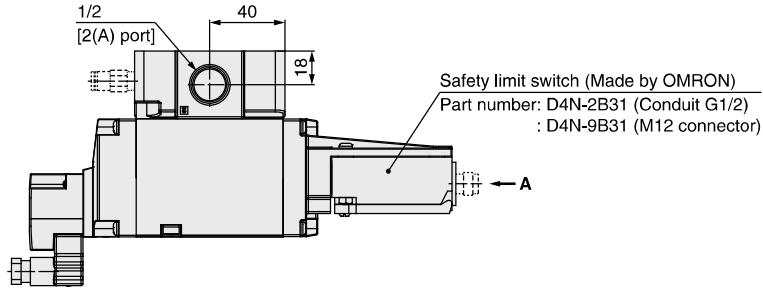

Port size: 1/8 (Without check valve)
Applicable tube O.D.: ø6, ø1/4" (With check valve)
(External pilot port)

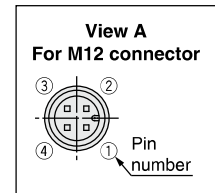
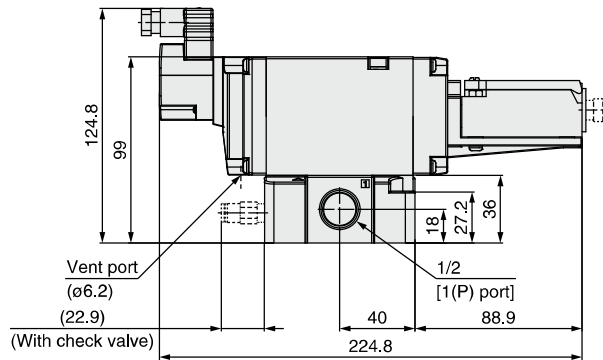
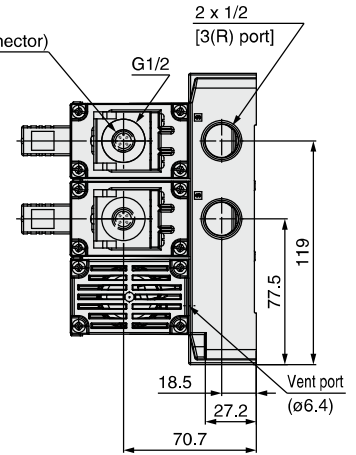
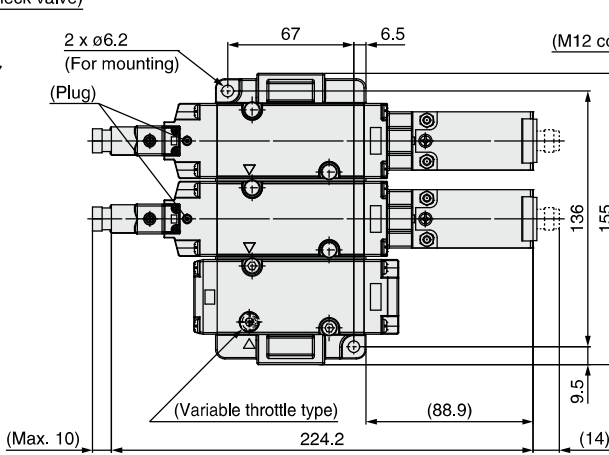
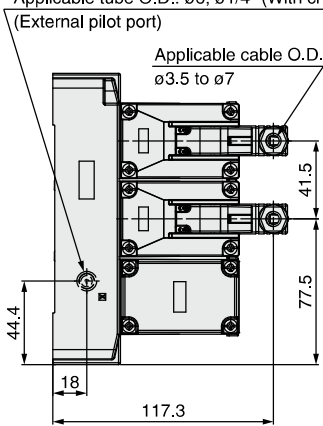

VP500/700

Symbols

X536

X538

X555

Optional Accessories

Specific Product Precautions

VG342

Symbols

X87

Specific Product Precautions

VP500/700-X555

Dimensions

Dual Residual Pressure Release Valve with Soft Start-up Function (-X555)

VP744(R)-5^DZ1-04□-S1□□-X555

Safety limit switch
 Made by
 Rockwell Automation

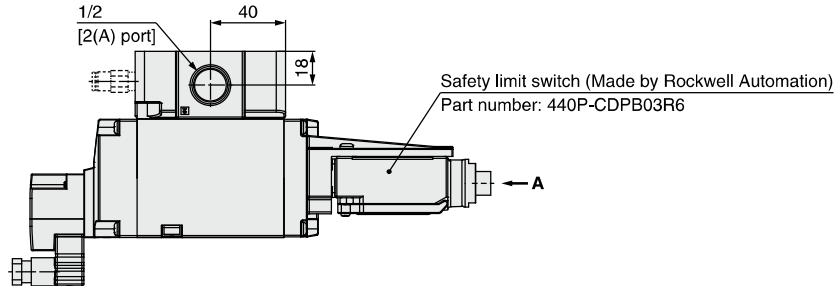

Port size: 1/8 (Without check valve)
 Applicable tube O.D.: $\phi 6$, $\phi 1/4$ " (With check valve)
 (External pilot port)

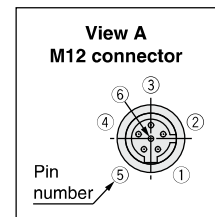
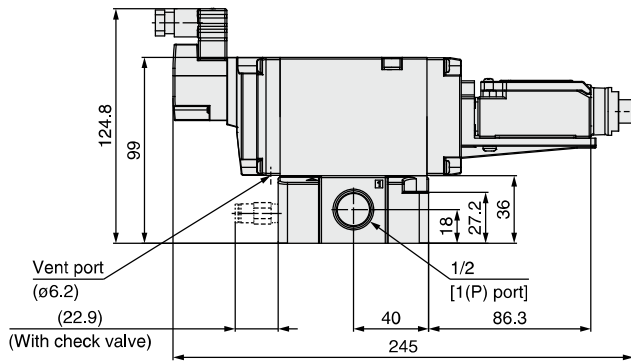
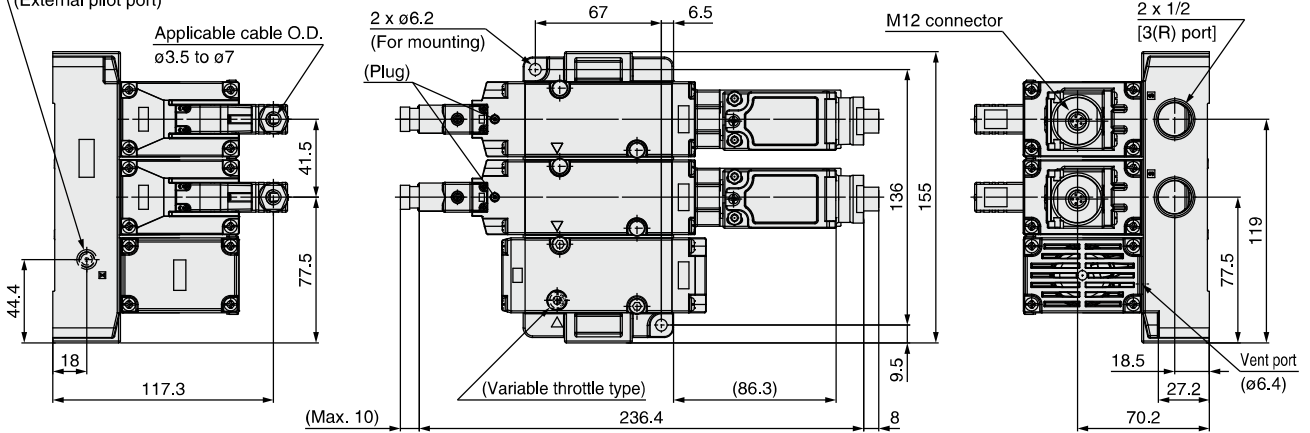

VP500/700-X536, X538, X555

Optional Accessories

For details on optional accessories, refer to the [Web Catalog](#).

Piping Adapter: 3/8, 1/2

A piping adapter allows installation/removal of the component without removing the piping and thus makes maintenance easier.

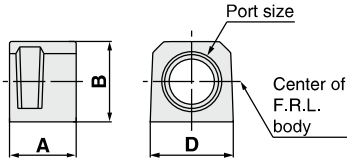

Part no. *1	Port size	A	B	D
E300-□03-A	3/8	31.8	30	30
E400-□04-A	1/2	31.8	36	36

*1 □ in part numbers indicates a pipe thread type. No indication is necessary for Rc; however, indicate N for NPT, and F for G.

* Separate interfaces are required for modular unit.

Ordering Example 1 *1

- Dual residual pressure release valve
VP544-5DZ1-03-X555 1 pc.
- Filter regulator
AW30-03G-A 1 pc.
- Spacer with bracket
Y300T-A 3 pcs.
- Piping adapter
E300-03-A 2 pcs.

*1 Products do not come assembled.

Dual residual pressure release valve
with soft start-up function

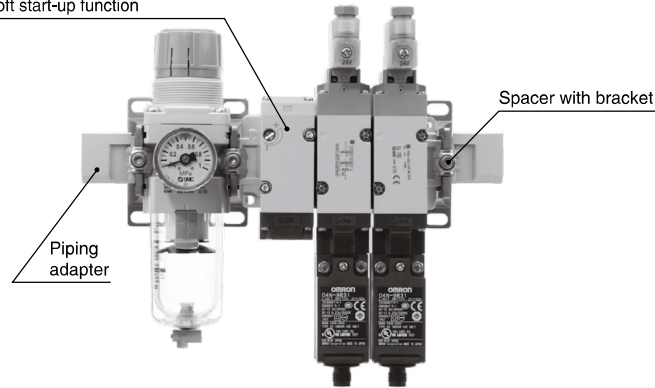

Ordering Example 2 *1

- Residual pressure release valve/
Base mounted
VP544R-5DZ1-03M-X536 ... 1 pc.
- Filter regulator
AW30-03G-A 1 pc.
- Spacer with bracket
Y300T-A 3 pcs.
- Piping adapter
E300-03-A 2 pcs.

*1 Products do not come assembled.

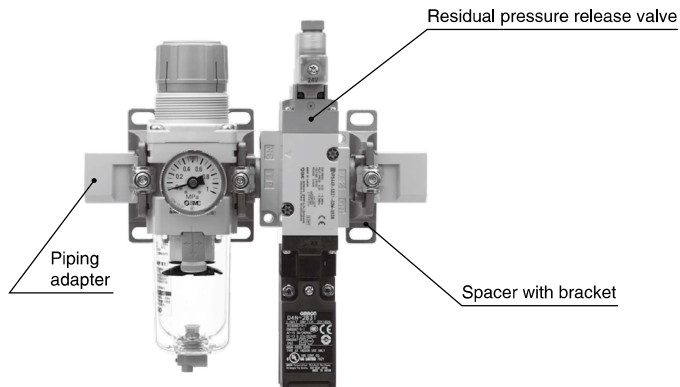

Spacer with Bracket

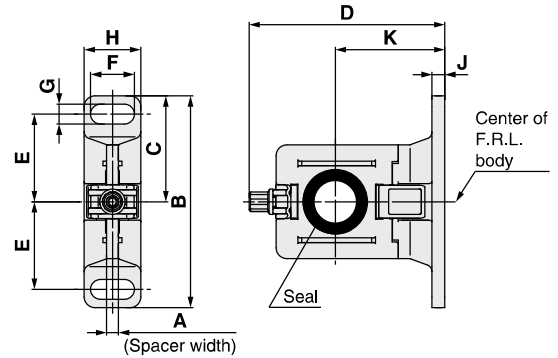

Part no.	A	B	C	D	E	F	G	H	J	K
Y300T-A	4.2	82	41	71.5	35	14	7	19	4	41
Y400T-A	5.2	96	48	86.1	40	18	9	26	5	50

VP500/700

Symbols

X536

X538

X555

Optional
Accessories

Specific Product
Precautions

VG342

Symbols

X87

Specific Product
Precautions

VP500/700-X536, X538, X555

Spacer with Bracket Mounting Position

Residual Pressure Release Valve (VP544/744-X536)

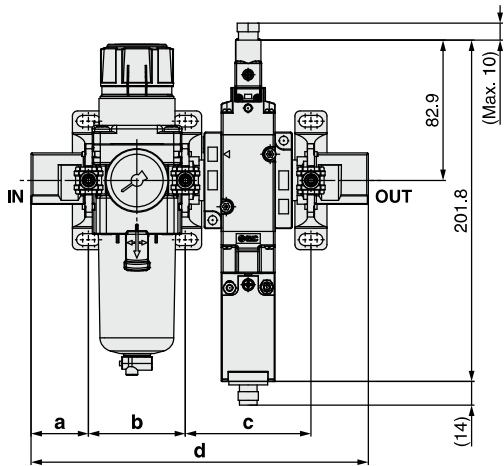

Model	a	b	c	d	Note
VP544R-5DZ1-03M□-X536	33.9	57.2	74.2	199.2	AW30-03G-A Y300T-A E300-03-A
VP744R-5DZ1-03M□-X536	34.4	75.2	89.2	233.2	AW40-04G-A Y400T-A E400-04-A

Dual Residual Pressure Release Valve (-X538)

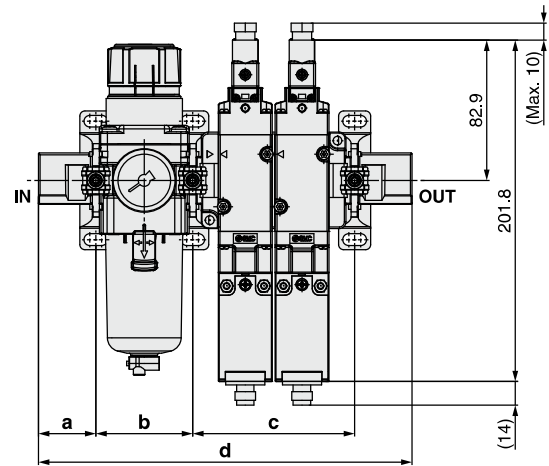

Model	a	b	c	d	Note
VP544R-5DZ1-03-X538	33.9	57.2	95.7	220.7	AW30-03G-A Y300T-A E300-03-A
VP744R-5DZ1-04-X538	34.4	75.2	118.7	262.7	AW40-04G-A Y400T-A E400-04-A

Dual Residual Pressure Release Valve with Soft Start-up Function (-X555)

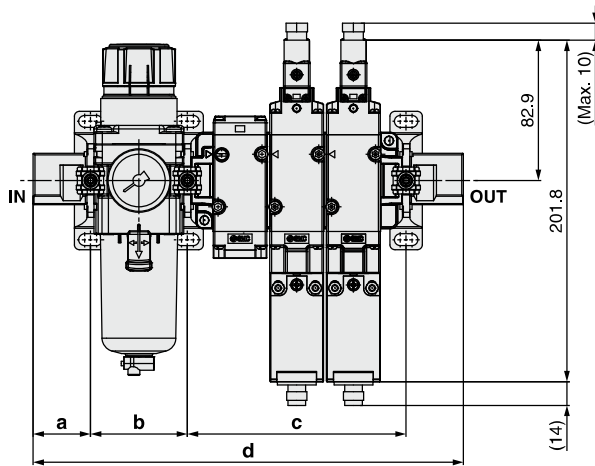

Model	a	b	c	d	Note
VP544-5DZ1-03-X555	33.9	57.2	129.2	254.2	AW30-03G-A Y300T-A E300-03-A
VP744-5DZ1-04-X555	34.4	75.2	160.2	304.2	AW40-04G-A Y400T-A E400-04-A



VP500/700-X536, X538, X555

Specific Product Precautions

Be sure to read this before handling the products. Refer to the back cover for safety instructions. For 3/4/5-port solenoid valve precautions, refer to the “Handling Precautions for SMC Products” and the “Operation Manual” on the SMC website: <http://www.smcworld.com>

How to Use DIN Terminal Connector

⚠ Caution Connection

1. Loosen the holding screw and pull the connector out of the solenoid valve terminal block.
2. After removing the holding screw, insert a flat blade screwdriver, etc., into the notch on the bottom of the terminal block and pry it open, separating the terminal block and the housing.
3. Loosen the terminal screws (slotted screws) in the terminal block. Insert the lead core wires into the terminals according to the connection method, and secure the wires by re-tightening the terminal screws.
4. Secure the cord by fastening the gland nut.

⚠ Caution

When making connections, please note that using a heavy-duty cord of a size outside of the range of supported sizes ($\phi 3.5$ to $\phi 7$) will not satisfy IP65 (enclosure) standards. Also, be sure to tighten the gland nut and holding screw within their specified torque ranges.

Changing the entry direction

After separating the terminal block and housing, the cord entry direction can be changed by rotating the housing in the desired direction (4 directions at 90° intervals).

* When equipped with a light, be careful not to damage the light with the cord's lead wires.

Precautions

Plug in and pull out the connector vertically without tilting it to one side.

Compatible cable

Cord O.D.: $\phi 3.5$ to $\phi 7$
(Reference) 0.5 mm², 2-core or 3-core, equivalent to JIS C 3306

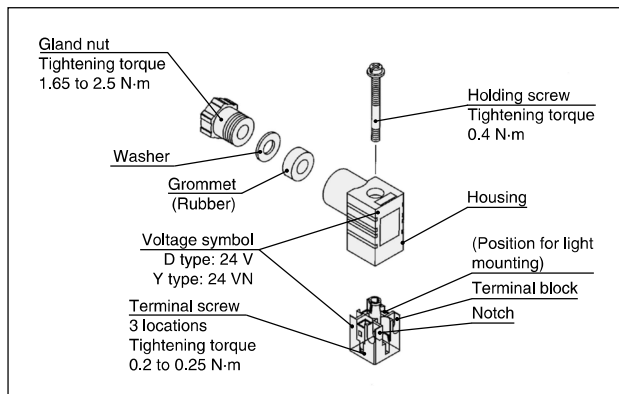

“Y” type

The Y type DIN connector is in compliance with the DIN standard of a 8 mm pitch between terminals.

- It is not interchangeable with the D type DIN connector with a 9.4 mm pitch between terminals.
- To distinguish it from the D type DIN connector, “N” is listed at the end of voltage symbol.
- The dimensions are the same as those of the D type DIN connector.

Light/Surge Voltage Suppressor

DIN Terminal

With light (DZ)
(YZ)

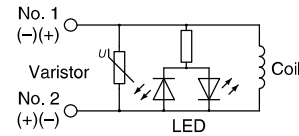

There is no polarity.

* The varistor surge voltage suppressor has residual voltage corresponding to the protective element and rated voltage; therefore, protect the controller side from the surge voltage.

Limit Switch Cable

An OMRON or Rockwell Automation M12 connector limit switch cable is available.

M12 Connector Cable (4 Pins) Made by OMRON

Part number	Cable length [mm]
ZS-37-L	300
ZS-37-M	500
ZS-37-N	1000
ZS-37-P	2000
ZS-37-C	5000

M12 Connector Cable (6 Pins) Made by Rockwell Automation

Part number	Cable length [mm]
VP500-231-1	2000

Rockwell Automation part number: 889R-F6ECA-2

* We recommend using one of the straight type M12 connector cables shown above. If the L type is used, the cable entry direction will not be fixed.

Installation

1. Use the external pilot type when using the VP500/700-X536 or X538 with the AV series. Install the AV series on the primary side.
2. For the VP500/700-X536 and X538 internal pilot type, even when the inlet pressure is within the operating pressure range, restricted piping, etc., may cause reduced flow on the inlet side, leading to the valve not operating properly.
 - The recommended piping size is 3/8" for the VP500 and 1/2" for the VP700. Also, use piping with an I.D. of 10 mm or larger for the VP500, and 13 mm or larger for the VP700.
 - When selecting a regulator or a filter regulator, use piping larger than the recommended size with sufficient flow rate characteristics.
 - For extended piping between the regulator and the valve (inlet piping), keep piping as short as possible (1 m or less).
 - For use under conditions other than those listed above, please use the external pilot type.
3. When using an external pilot for the VP500/700-X536 or X538, supply pressure to the external pilot via piping from a separate, stable line. Also, if the external pilot pressure is to be branched off from the same piping, in order to prevent the negative effects a pressure drop in the main piping can have on the pilot air piping, be sure to take measures such as installing a check valve on the pilot air piping after branching off, etc.

VP500/700

Symbols

X536

X538

X555

Optional Accessories

Specific Product Precautions

VG342

Symbols

X87

Specific Product Precautions

3-Port Solenoid Valve/ Residual Pressure Release Valve with Detection of Main Valve Position

VG342-X87



How to Order

Dual Residual Pressure Release Valve

VG342 **R** - **5** **DZ** - **06** **□** - **M** **□** - X87

①
②
③
④
⑤
⑥
⑦

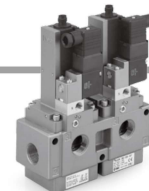

① Pilot

Nil	Internal pilot
R	External pilot

* Refer to Installation on page 30 before selecting the internal pilot type.

② Voltage

5	24 VDC
----------	--------

③ Electrical entry

DZ	DIN terminal. With light/surge voltage suppressor
-----------	---

④ Port size

06	3/4
10	1

⑤ Thread

Nil	Rc
F	G
N	NPT

⑥ Safety limit switch/Wiring

M	M12 connector (Made by OMRON)
S1	M12 connector (Made by Rockwell Automation)

⑦ With check valve (Only external pilot)

Symbol	Check valve	Applicable tube O.D.	Thread		
			Rc	G	NPT
Nil	None	—	●	●	●
A	Yes	ø8	●	—	—
B		ø5/16"	—	—	●

* For the internal pilot, the symbol is nil.

* Refer to Piping for External Pilot Type on page 24 for selection of the check valve.

Made to Order

1 Series Compatible with Secondary Batteries

For details on 25A-, refer to the **Web Catalog** "Series Compatible with Secondary Batteries/25A- Series."

How to Order

25A-VG342 **□** - **5DZ** - **□□** - **M** **□** - X87

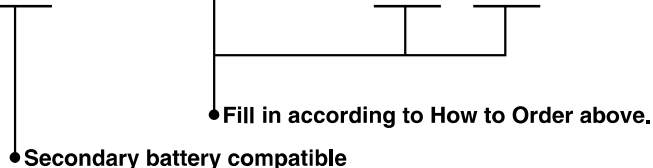

* Electrical entry can be selected only for D type. Check valve type is available only when the thread type is Rc.

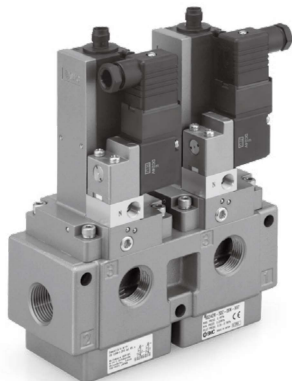

Valve Specifications

Fluid	Air	
Type of actuation	N.C. (Spring return)	
Operation	Internal pilot	External pilot
Operating pressure range	0.25 to 0.7 MPa	0.25 to 0.7 MPa
External pilot pressure	—	0.25 to 0.7 MPa (Same as operating pressure)
Maximum operating frequency	30 cycles/minute	
Minimum operating frequency	1 cycle/week	
Operating and ambient temperatures	-10 to 50°C (No freezing)	
Ambient humidity	95% RH or less (No condensation)	
Manual override	None	
Pilot exhaust	Individual exhaust	
Lubrication	Not required	
Mounting orientation	Unrestricted	
Impact/Vibration resistance	150/50 m/s ²	
Enclosure	IP40	
Operating environment	Indoors	
Weight	2.8 kg (1" type: 3.2 kg)	2.9 kg (1" type: 3.3 kg)
B10D (MTTFd calculation)	1,000,000 cycles	

Internal Pilot Type

⚠ Caution

Even when the inlet pressure is within the operating pressure range, restricted piping, etc., may cause reduced flow on the inlet side, leading to the valve not operating properly. Refer to Installation in the Specific Product Precautions for details.

Piping for External Pilot Type

⚠ Caution

The product may not operate when the external pilot pressure is insufficient due to simultaneous operation or restricted air piping. In this case, use the check valve (AKH series) with the external pilot port, change the piping size or adjust the set pressure to provide a constant pressure of 0.25 MPa or more.

Flow-rate Characteristics

Model	Flow-rate characteristics					
	1→2 (P→A)			2→3 (A→R)		
	C [dm ³ /(s·bar)]	b	Cv	C [dm ³ /(s·bar)]	b	Cv
VG342-06-X87	26.6	0.04	5.5	28.6	0.03	5.6
VG342-10-X87	25.5	0.03	5.4	27.4	0.01	5.3

Solenoid Specifications

Electrical entry	DIN terminal
Rated voltage	24 VDC
Allowable voltage fluctuation	-15% to +10% of the rated voltage
Power consumption	2.2 W
Suppressor	Diode
Indicator	LED

Safety Limit Switch Specifications

Manufacturer	OMRON	Rockwell Automation
Electrical wiring	M12 connector	
Contact resistance	25 mΩ or less	50 mΩ or less
Min. applicable load	5 VDC, 1 mA (Load resistance)	5 VDC, 5 mA (Load resistance)
Max. voltage	24 VDC	
Max. load current	50 mA	
Max. load inductance	0.5 H	
Insulation voltage	300 V	600 V
Protection against electric shock	Class II (EN 60947-5-1:2004)	

VP500/700

Symbols

X536

X538

X555

Optional Accessories

Specific Product Precautions

VG342

Symbols

X87

Specific Product Precautions

VG342-X87

Symbols

Safety limit switch
Made by
OMRON

Symbol

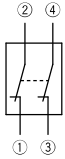

Pin Numbers (Built-in switch 2 N.C.)

M12 connector pin number	Wiring specification
①	
②	
③	
④	

VG342(R)-X87

Internal pilot

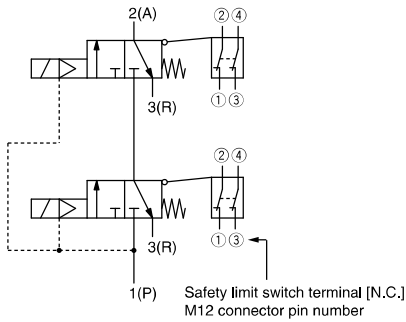

External pilot

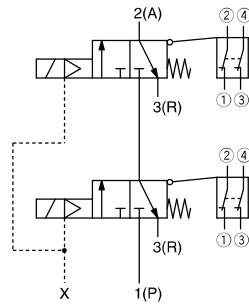

External pilot/With check valve

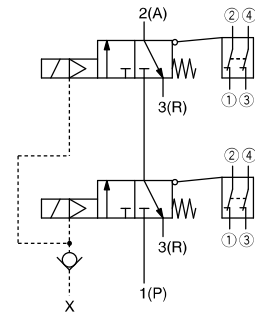

Safety limit switch
Made by
Rockwell Automation

Symbol

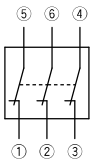

Pin Numbers (Built-in switch 3 N.C.)

M12 connector pin number	Wiring specification
①	
⑤	
②	
⑥	
③	
④	

VG342(R)-X87

Internal pilot

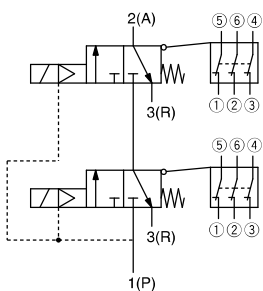

External pilot

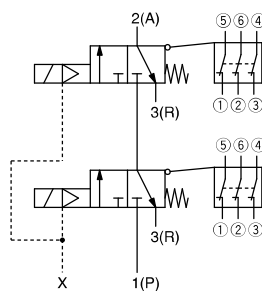

External pilot/With check valve

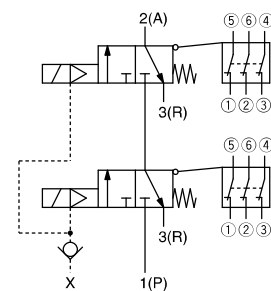

Dimensions

Dual Residual Pressure Release Valve (-X87)

VG342(R)-5DZ-06□-M□-X87

Safety limit switch
Made by OMRON

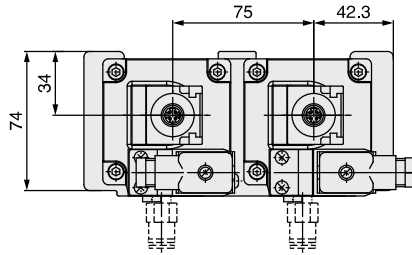

Port size: 1/8 (Without check valve)
Applicable tube O.D.: ø8, ø5/16" (With check valve)
(External pilot port)

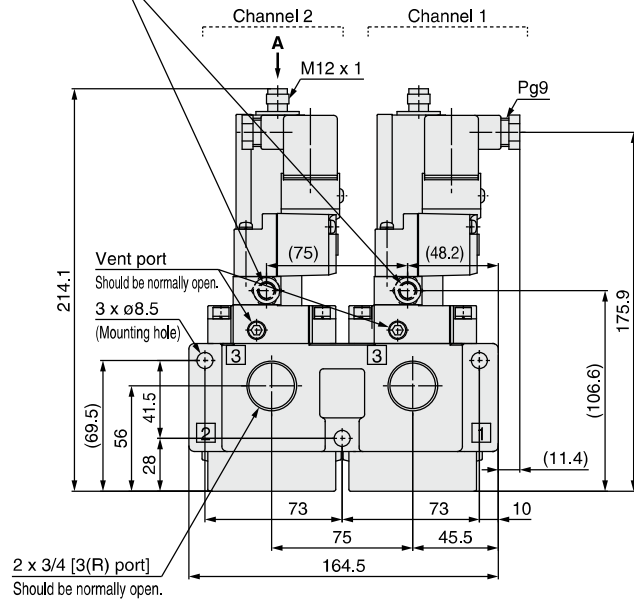
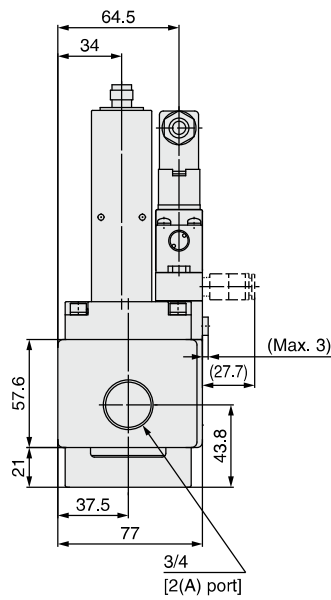

Safety limit switch (Made by OMRON)
Part number: D4N-9B31
Applicable cable O.D.
ø4.5 to ø7

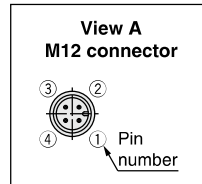
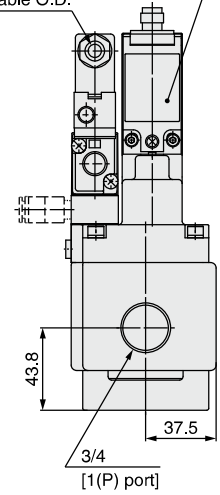

VP500/700

Symbols

X536

X538

X555

Optional Accessories

Specific Product Precautions

VG342

Symbols

X87

Specific Product Precautions

VG342-X87

Dimensions

Dual Residual Pressure Release Valve (-X87)

VG342(R)-5DZ-10□-M□-X87

Safety limit switch
Made by
OMRON

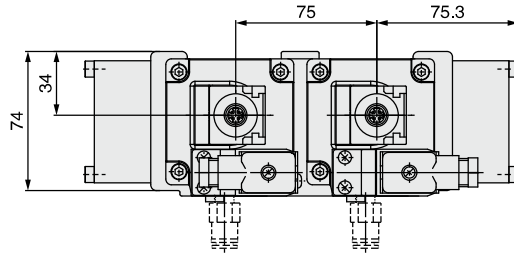

Port size: 1/8 (Without check valve)
Applicable tube O.D.: $\phi 8, \phi 5/16"$ (With check valve)
(External pilot port)

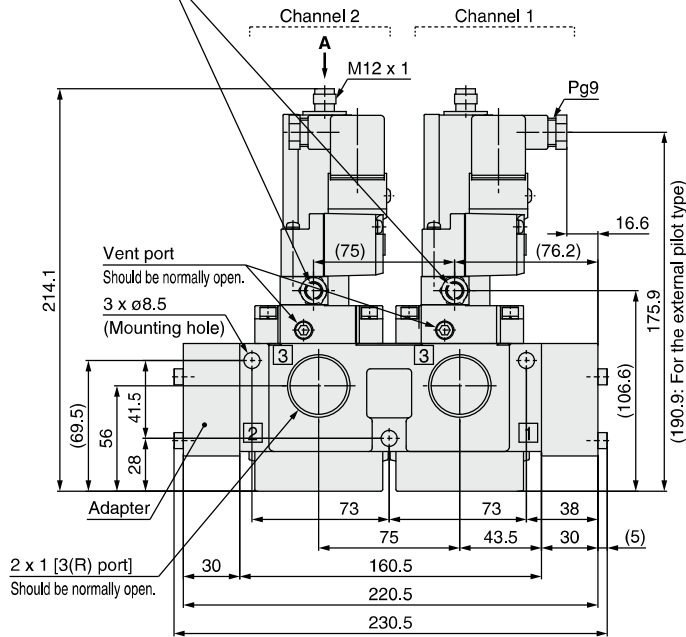
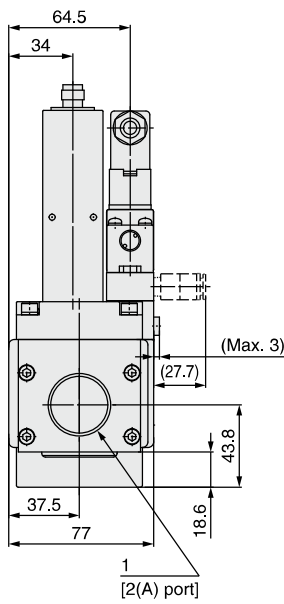

Safety limit switch (Made by OMRON)
Part number: D4N-9B31
Applicable cable O.D.
 $\phi 4.5$ to $\phi 7$

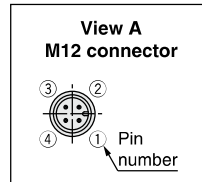
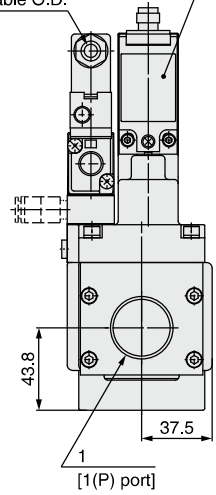

Dimensions

Dual Residual Pressure Release Valve (-X87)

VG342(R)-5DZ-06□-S1□-X87

Safety limit switch
Made by
Rockwell Automation

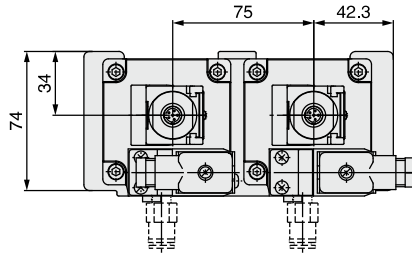

Port size: 1/8 (Without check valve)
Applicable tube O.D.: $\varnothing 8, \varnothing 5/16"$ (With check valve)
(External pilot port)

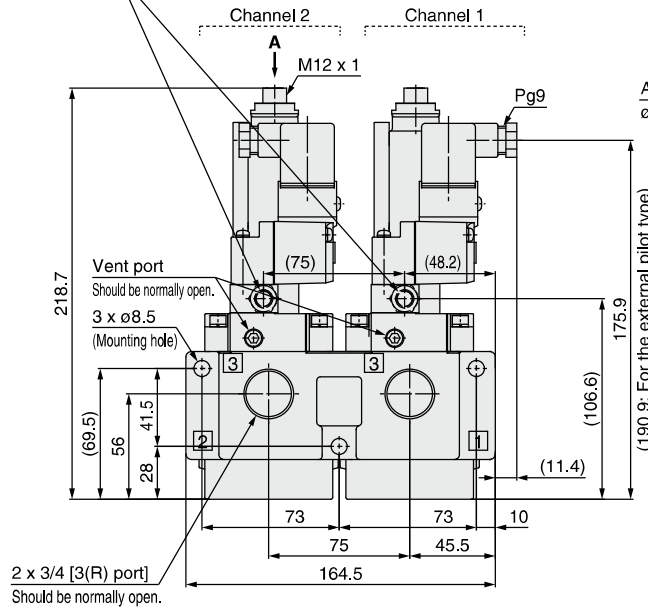
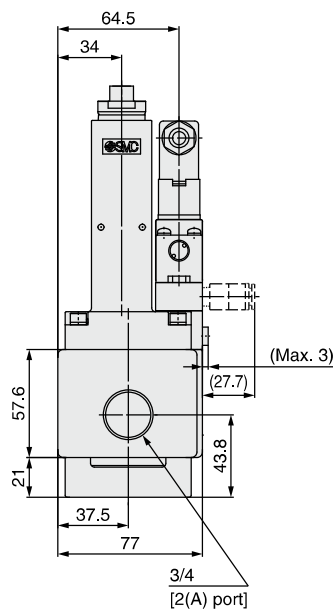

Safety limit switch
(Made by Rockwell Automation)
Part number: 440P-CDPB03R6

Applicable cable O.D.
 $\varnothing 4.5$ to $\varnothing 7$

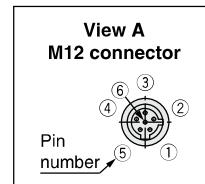
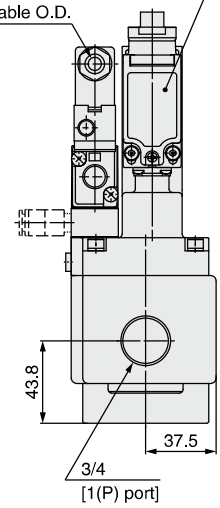

VP500/700

Symbols

X536

X538

X555

Optional
Accessories

Specific Product
Precautions

VG342

Symbols

X87

Specific Product
Precautions

VG342-X87

Dimensions

Dual Residual Pressure Release Valve (-X87)

VG342(R)-5DZ-10□-S1□-X87

Safety limit switch
**Made by
 Rockwell Automation**

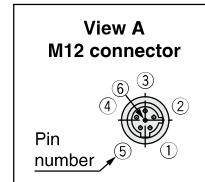
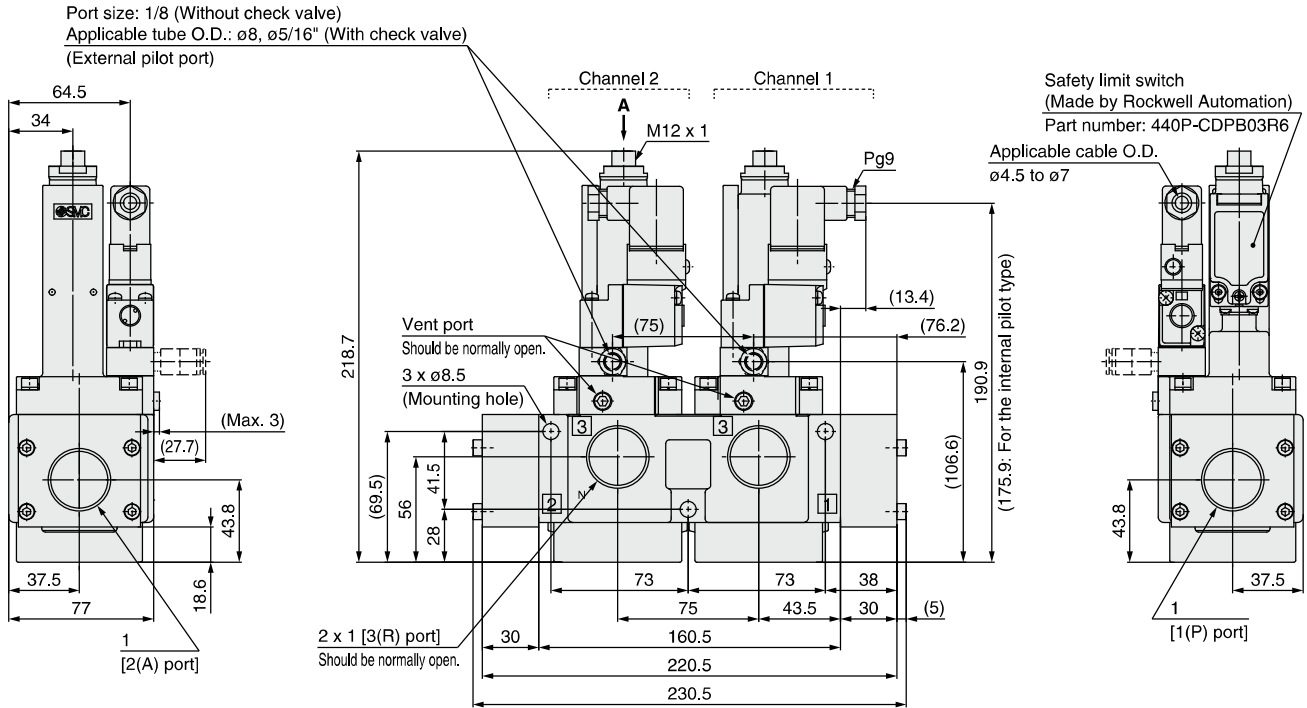
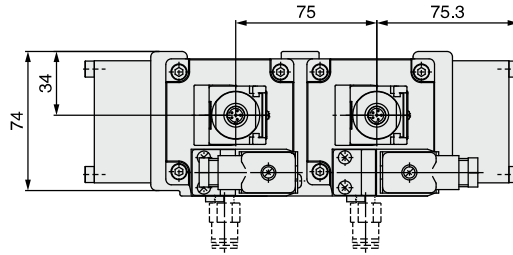



VG342-X87

Specific Product Precautions

Be sure to read this before handling the products. Refer to the back cover for safety instructions. For 3/4/5-port solenoid valve precautions, refer to the “Handling Precautions for SMC Products” and the “Operation Manual” on the SMC website: <http://www.smcworld.com>

How to Use DIN Terminal Connector

⚠ Caution

Connection

- Loosen the holding screw and pull the connector out of the solenoid valve terminal block.
- After removing the holding screw, insert a flat blade screwdriver, etc., into the notch on the bottom of the terminal block and pry it open, separating the terminal block and the housing.
- Loosen the terminal screws in the terminal block. Insert the lead core wires into the terminals, and secure the wires by re-tightening the terminal screws.
As the product has polarity, be sure to wire the product correctly in accordance with the terminal number symbols of the terminal block while referring to the electric circuit diagram.
- Secure the cord by fastening the gland nut.
Tighten the gland nut and holding screw within their specified torque ranges.

Changing the entry direction

After separating the terminal block and housing, the cord entry direction can be changed by rotating the housing in the opposite direction by 180°.

* Be careful not to damage the element, etc., with the cord's lead wires.

Precautions

Plug in and pull out the connector vertically without tilting it to one side.

Compatible cable

Cord O.D.: $\varnothing 4.5$ to $\varnothing 7$
(Reference) 0.5 to 1.5 mm², 2-core or 3-core, equivalent to JIS C 3306

Applicable crimped terminals

O-terminals: Equivalent to R1.25-4M defined in the JIS C 2805
Y-terminals: Equivalent to 1.25-3L made by J.S.T. Mfg. Co., Ltd.
Rod-terminals: Up to size 1.5

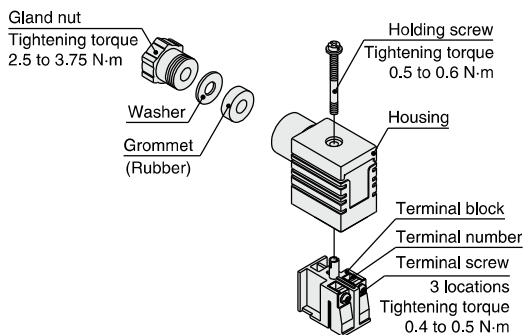

Light/Surge Voltage Suppressor

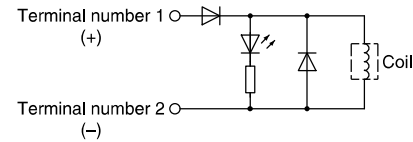

Limit Switch Cable

An OMRON or Rockwell Automation M12 connector limit switch cable is available.

M12 Connector Cable (4 Pins) Made by OMRON

Part number	Cable length [mm]
ZS-37-L	300
ZS-37-M	500
ZS-37-N	1000
ZS-37-P	2000
ZS-37-C	5000

M12 Connector Cable (6 Pins) Made by Rockwell Automation

Part number	Cable length [mm]
VP500-231-1	2000

Rockwell Automation part number: 889R-F6ECA-2

- We recommend using one of the straight type M12 connector cables shown above. If the L type is used, the cable entry direction will not be fixed.

Installation

For the VG342-X87 internal pilot type, even when the inlet pressure is within the operating pressure range, restricted piping, etc., may cause reduced flow on the inlet side, leading to the valve not operating properly.

- The recommended piping size is 3/4" or larger. Also, use piping with an I.D. of 19 mm or larger.
- When selecting a regulator or a filter regulator, use piping larger than the recommended size with sufficient flow rate characteristics.
- For extended piping between the regulator and the valve (inlet piping), keep piping as short as possible (2 m or less).
- For use under conditions other than those listed above, please use the external pilot type.

VP500/700

Symbols

X536

X538

X555

Optional Accessories

Specific Product Precautions

VG342

Symbols

X87

Specific Product Precautions

Safety Instructions

These safety instructions are intended to prevent hazardous situations and/or equipment damage. These instructions indicate the level of potential hazard with the labels of “Caution,” “Warning” or “Danger.” They are all important notes for safety and must be followed in addition to International Standards (ISO/IEC)*1), and other safety regulations.

 **Caution:** Caution indicates a hazard with a low level of risk which, if not avoided, could result in minor or moderate injury.

 **Warning:** Warning indicates a hazard with a medium level of risk which, if not avoided, could result in death or serious injury.

 **Danger:** Danger indicates a hazard with a high level of risk which, if not avoided, will result in death or serious injury.

*1) ISO 4414: Pneumatic fluid power – General rules relating to systems.
ISO 4413: Hydraulic fluid power – General rules relating to systems.
IEC 60204-1: Safety of machinery – Electrical equipment of machines.
(Part 1: General requirements)
ISO 10218-1: Manipulating industrial robots – Safety.
etc.

Warning

1. The compatibility of the product is the responsibility of the person who designs the equipment or decides its specifications.

Since the product specified here is used under various operating conditions, its compatibility with specific equipment must be decided by the person who designs the equipment or decides its specifications based on necessary analysis and test results. The expected performance and safety assurance of the equipment will be the responsibility of the person who has determined its compatibility with the product. This person should also continuously review all specifications of the product referring to its latest catalog information, with a view to giving due consideration to any possibility of equipment failure when configuring the equipment.

2. Only personnel with appropriate training should operate machinery and equipment.

The product specified here may become unsafe if handled incorrectly. The assembly, operation and maintenance of machines or equipment including our products must be performed by an operator who is appropriately trained and experienced.

3. Do not service or attempt to remove product and machinery/equipment until safety is confirmed.

1. The inspection and maintenance of machinery/equipment should only be performed after measures to prevent falling or runaway of the driven objects have been confirmed.
2. When the product is to be removed, confirm that the safety measures as mentioned above are implemented and the power from any appropriate source is cut, and read and understand the specific product precautions of all relevant products carefully.
3. Before machinery/equipment is restarted, take measures to prevent unexpected operation and malfunction.

4. Contact SMC beforehand and take special consideration of safety measures if the product is to be used in any of the following conditions.

1. Conditions and environments outside of the given specifications, or use outdoors or in a place exposed to direct sunlight.
2. Installation on equipment in conjunction with atomic energy, railways, air navigation, space, shipping, vehicles, military, medical treatment, combustion and recreation, or equipment in contact with food and beverages, emergency stop circuits, clutch and brake circuits in press applications, safety equipment or other applications unsuitable for the standard specifications described in the product catalog.
3. An application which could have negative effects on people, property, or animals requiring special safety analysis.
4. Use in an interlock circuit, which requires the provision of double interlock for possible failure by using a mechanical protective function, and periodical checks to confirm proper operation.

Caution

1. The product is provided for use in manufacturing industries.

The product herein described is basically provided for peaceful use in manufacturing industries.
If considering using the product in other industries, consult SMC beforehand and exchange specifications or a contract if necessary.
If anything is unclear, contact your nearest sales branch.

Limited warranty and Disclaimer/ Compliance Requirements

The product used is subject to the following “Limited warranty and Disclaimer” and “Compliance Requirements”.

Read and accept them before using the product.

Limited warranty and Disclaimer

1. The warranty period of the product is 1 year in service or 1.5 years after the product is delivered, whichever is first.*2)
Also, the product may have specified durability, running distance or replacement parts. Please consult your nearest sales branch.
2. For any failure or damage reported within the warranty period which is clearly our responsibility, a replacement product or necessary parts will be provided. This limited warranty applies only to our product independently, and not to any other damage incurred due to the failure of the product.
3. Prior to using SMC products, please read and understand the warranty terms and disclaimers noted in the specified catalog for the particular products.

*2) Vacuum pads are excluded from this 1 year warranty.

A vacuum pad is a consumable part, so it is warranted for a year after it is delivered. Also, even within the warranty period, the wear of a product due to the use of the vacuum pad or failure due to the deterioration of rubber material are not covered by the limited warranty.

Compliance Requirements

1. The use of SMC products with production equipment for the manufacture of weapons of mass destruction (WMD) or any other weapon is strictly prohibited.
2. The exports of SMC products or technology from one country to another are governed by the relevant security laws and regulations of the countries involved in the transaction. Prior to the shipment of a SMC product to another country, assure that all local rules governing that export are known and followed.

Caution

SMC products are not intended for use as instruments for legal metrology.

Measurement instruments that SMC manufactures or sells have not been qualified by type approval tests relevant to the metrology (measurement) laws of each country. Therefore, SMC products cannot be used for business or certification ordained by the metrology (measurement) laws of each country.

Revision History

- Edition B**
- * Base-mounted type (VP544-X536, VP744-X536) residual pressure release valves have been added.
 - * The service life of the safety limit switch made by Rockwell Automation has been changed.
 - * The VG-X87 with a safety limit switch made by Rockwell Automation has been added to safety certified products.
 - * A precaution regarding installation has been added to the specific product precautions.
 - * Number of pages has been increased from 28 to 32.

WX

Safety Instructions

Be sure to read the “Handling Precautions for SMC Products” (M-E03-3) and “Operation Manual” before use.