

REVISIONS					
REV	ECO	DESCRIPTION	DATE	BY	APPR
A1	-	TECHNICAL DATA SHEET RELEASE	12-MAY-14	KMM	RFC

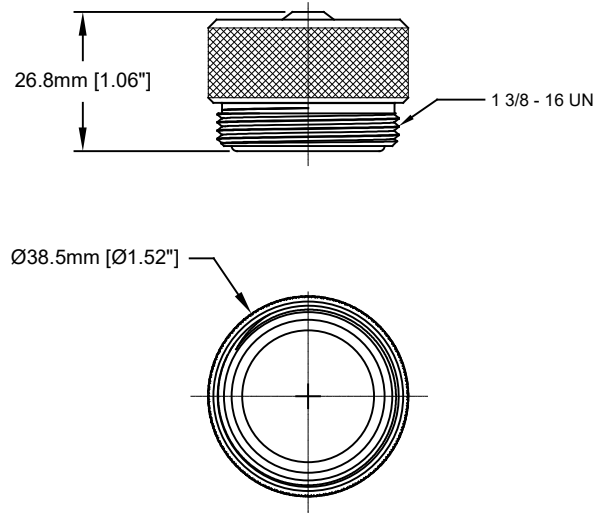

Risk of Electrical Shock
Do Not Disconnect Under Load.
Risque de chocs électriques
Ne pas débrancher sous tension.

WARNING

Amphenol P/N	ROCKWELL P/N	MOLEX	TURCK
P29043	889A-QMCAP	55-0198	GSDM-CC

TECHNICAL DATA:

- 1) MATERIALS:
HOUSING: MACHINED ALUMINUM, ANODIZED
- 2) RoHS COMPLIANT

QUANTITY	PART NUMBER	DESCRIPTION	ITEM										
MATERIALS LIST													
<small>UNLESS OTHERWISE SPECIFIED</small> 1) All dimensions are in metric (mm). 2) Tolerances are as follows: 1 PL DEC ±0.30 Fractions ±1/64 2 PL DEC ±0.15 Angles ±1° 3 PL DEC ±0.08 3) Note reference =		<table border="1"> <thead> <tr> <th>SIGNATURES</th> <th>DATE</th> </tr> </thead> <tbody> <tr> <td>DRAWN: KMM</td> <td>12-MAY-14</td> </tr> <tr> <td>CHECKED: MRF</td> <td>12-MAY-14</td> </tr> <tr> <td>ENGINEER: KMM</td> <td></td> </tr> <tr> <td>APPROVAL: RFC</td> <td>12-MAY-14</td> </tr> </tbody> </table>	SIGNATURES	DATE	DRAWN: KMM	12-MAY-14	CHECKED: MRF	12-MAY-14	ENGINEER: KMM		APPROVAL: RFC	12-MAY-14	<p style="text-align: center;">Amphenol</p> <p style="text-align: center;">Sine Systems - www.amphenol-sine.com 44724 Morley Drive Clinton Township, MI 48036</p>
SIGNATURES	DATE												
DRAWN: KMM	12-MAY-14												
CHECKED: MRF	12-MAY-14												
ENGINEER: KMM													
APPROVAL: RFC	12-MAY-14												
MATERIAL SPECIFICATIONS: PROCESS SPECIFICATIONS: NEXT ASSY:		CUSTOMER: THIS DRAWING IS SUPPLIED FOR INFORMATION ONLY. DESIGN FEATURES, SPECIFICATIONS AND PERFORMANCE DATA SHOWN HEREON ARE THE PROPERTY OF THE AMPHENOL CORPORATION. NO RIGHTS OF REPRODUCTION ARE IMPLIED. ALL DIMENSIONS ARE SUBJECT TO NORMAL MANUFACTURING VARIATIONS.	<p style="text-align: center;">M35 PB LITE, CLOSURE CAP FOR FEMALE CONNECTOR, TRUNK</p> <table border="1"> <thead> <tr> <th>SIZE</th> <th>TYPE</th> <th>DWG NO.</th> <th>REVISION</th> </tr> </thead> <tbody> <tr> <td>C-</td> <td></td> <td>P29043</td> <td>A1</td> </tr> </tbody> </table>	SIZE	TYPE	DWG NO.	REVISION	C-		P29043	A1		
SIZE	TYPE	DWG NO.	REVISION										
C-		P29043	A1										
		SCALE: FULL	C-P29043 SHEET 1 OF 1										

TITLE: M35 PB LITE, CLOSURE CAP, FEMALE, TRUNK
 DWG NO.: C-P29043
 REV: A1
 SH: 1
 OF: 1