

25249-FBA

1-Gang 15 Amp Duplex Receptacle Floor Box Assembly, Brass

1-Gang Floor Box Receptacle Assembly, 15 Amp, 125 Volt, NEMA 5-15R, 2P, 3W, Floor Mtg Duplex Receptacle, Straight Blade, Commercial Grade, Self Grounding, Back & Side Wired, Steel Strap - IVORY

For low profile, in-floor receptacle installations, our Floor Box Receptacle Assemblies are the perfect fit. Available in both 15 & 20 Amp 1- and 2-gang configurations, these devices are suitable for wood frame construction with carpet, wood, tile, and vinyl finished flooring. Common applications include a variety of uses from home office workstations to high-end stages and entertainment venues.



UPC Code : 078477163597

Country Of Origin : Mexico



Technical Information

AC Horsepower Ratings

At Rated Voltage : 1/2 HP

Electrical Specifications

Amperage : 15 A

Current Limiting : Full Rated Current

Dielectric Voltage : Withstands 2000V per UL498

Grounding : Self Grounding

Pole : 2

Temperature Rise : Max 30C after 50 cycles OL at 150 percent rated current

Voltage : 125 VAC

Wire : 3

Environmental Specifications

Flammability : Rated V-2 per UL 94

Operating Temperature : -40°C to 60°C

Material Specifications

Body Material : Nylon

Clamp Nuts : Zinc-Plated Steel

Color : Ivory

Face Material : Nylon

Floorplate Material : Solid Brass 0.060 In Thick

Ground Clips : Brass-Plated

Grounding Screw : Brass 8-32

Line Contacts : Brass Triple-Wipe .031 Thick

Strap Material : Zinc-Plated Steel

Terminal Screws : Brass 8-32

Mechanical Specifications

Product ID : Ratings are permanently marked on device

Terminal Accom. : 14-10 AWG

Terminal ID : Brass-Hot, Green-Ground, Silver-Neutral

Termination : Back & Side

Product Features

Amperage : 15 A

Color : Ivory

Grounding : Self Grounding

NEMA : 5-15R

Type : Wood Frame

Voltage : 125 VAC

Standards and Certifications

ANSI : C-73

Applicable Standards : UL 498, UL514A, CSA C22.2 No. 42, CSA C22.2 No 18.1-04

Certification/Listing : cCSAus, NOM-ANCE

NEMA : WD-1 & WD-6

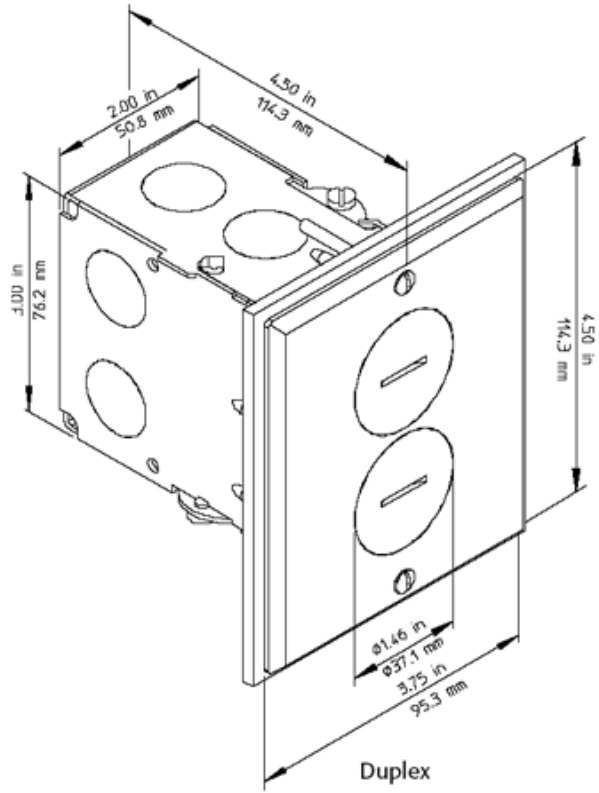

Wiring Diagram

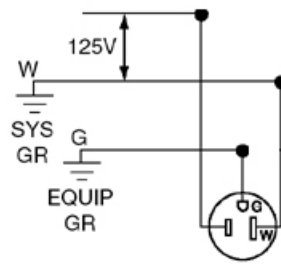

5-15R

SPECIFICATION SUBMITTAL

JOB NAME:	CATALOG NUMBERS:	
JOB NUMBER:		

Leviton Manufacturing Co., Inc.

201 North Service Road, Melville, NY 11747

Telephone: +1-800-323-8920 · FAX: +1-800-832-9538 · Tech Line (8:30AM-7:30PM E.S.T. Monday-Friday):
+1-800-824-3005

Leviton Manufacturing of Canada, Ltd.

165 Hymus Boulevard, Pointe Claire, Quebec H9R 1E9 · Telephone: +1-800-469-7890 ·
FAX: +1-800-824-3005 · www.leviton.com/canada

Leviton S. de R.L. de C.V.

Lago Tana 43, Mexico DF, Mexico CP 11290 · Tel.: (+52)55-5082-1040 · FAX: (+52)5386-
1797 · www.leviton.com.mx

Visit our Website at: www.leviton.com

© 2021 Leviton Manufacturing Co., Inc. All Rights Reserved. Subject to change without notice.

Leviton has a global presence.

If you would like to know where your local Leviton office is located please go to:
www.leviton.com/international/contacts/

