

Datasheet

SP Roller Lever Microswitch, 2 A@ 250 V ac

RS Stock 804-6265

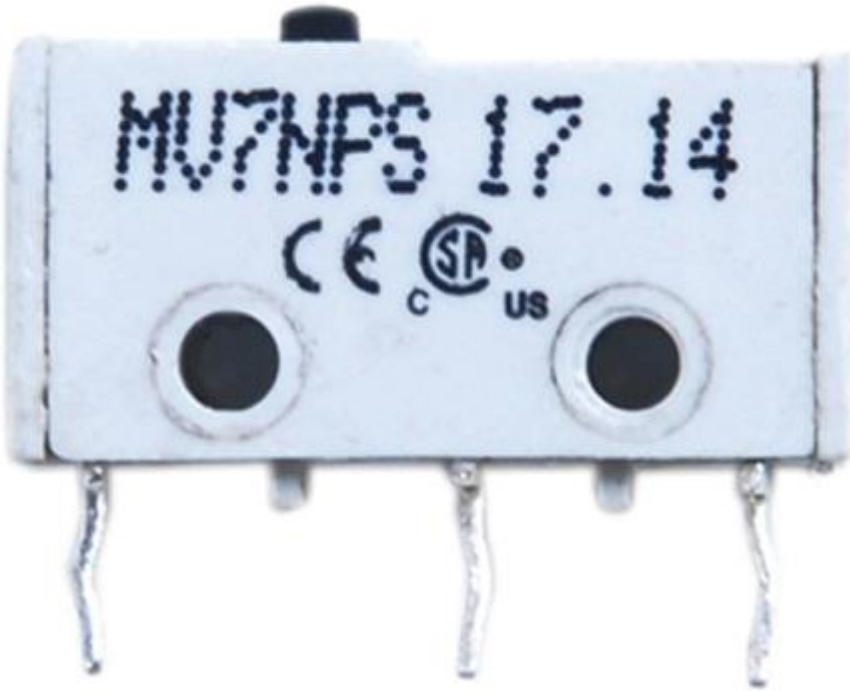

Dimensions: (mm)

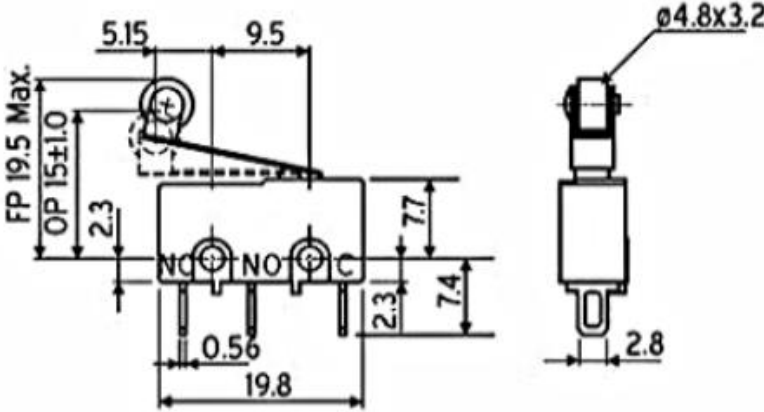

-
- Characteristics
- Designed for applications where low operating force is required.
 - Single pole changeover.
 - Fine silver contacts.
 - High precision snap action mechanism.
 - Moulded from flame retardant thermoplastic (UL94V-O)
 - Long mechanical & electrical life.
 - Solder or PC board terminals.
 - Silver / Gold plated terminals.
 - Conform to IEC 1058-1 standard.
-



Approval



Actuating force	50 gms. (max.)
Release force	2.5 gms. (min.)
Pretravel	4.5 mm. (max.)
Overtravel	1.18 mm.
Movement differential	1.10 mm. (max.)
Salient features	Integral Lever with free running Nylon roller solder terminals

ELECTRICAL RATINGS

Load	Ratings
AC	5 A at 250V 2 A at 250V (for low force models.)
DC (resistive)	0.5 A at 125V or 0.25 A at 250V. 0.25A at 125V and 250V (for low force models.)
DC (inductive)	0.06 A at 110V & 0.03 A at 250V. 0.03 A at 110V and 0.02A at 250V (for low force models.)