

Datasheet

**SPDT Long Roller Lever Microswitch, 0.1 A@ 110 V dc,
0.6 A@ 110 V dc, 16 A@ 250 V ac**
RS Stock 804-6259

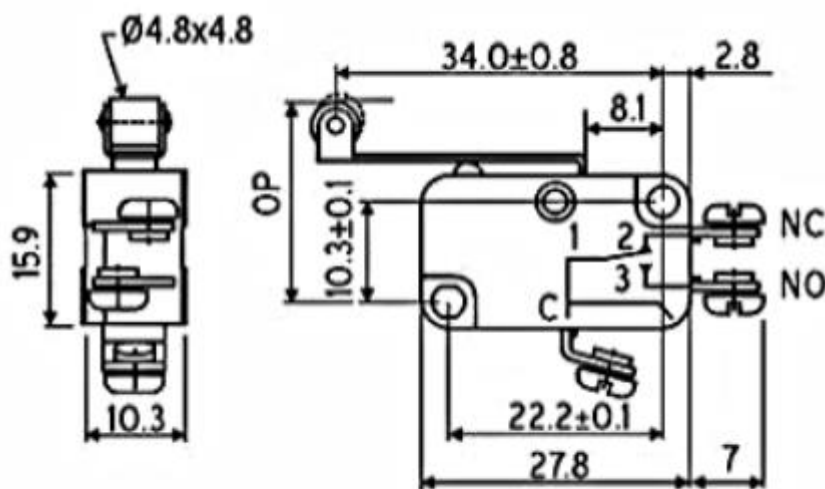

Dimensions: (mm)





ELECTRICAL RATING

LOAD	RATINGS (for micro switch with 400/200 gms. actuating force)
AC	16 Amp at 250V 5 Amp at 440V
DC (Resistive)	0.6 Amp at 110V 0.3 Amp at 220V
DC (Inductive)	0.1 Amp at 110V 0.05 Amp at 220V

Voltage proof	1500 VAC between each terminal and 1000VAC between open contacts
Contact resistance	15 milliohms max. (initial)
Insulation resistance	100Mohms min. at 500VDC
Electrical life	100,000 operations at rated load
Mechanical life	10,000,000 operations

ENVIRONMENTAL

Temperature -55°C to +85°C

APPLICATIONS :

Automotive, Machine control, Telecommunication equipments, Vending equipments, Security Products, Defence, Business automation machines, Instruments

- Note :** (i) For 100 gms. actuating force rated current is 10 A at 250V AC
For 50 gms. actuating force rated current is 6 A at 250V AC
(ii) Knob Colour : Black - 400 gms., Red - 200 gms., Green - 100 gms., Yellow - 50 gms.
(iii) OF : Operating force FP : Free position OP : Operating position
RF : Release force MD : Movement differential
OT : Over travel PT : Pre travel

Pretravel (PT)	4.0 mm. (max.)
Overtravel	1.6 mm.
Movement differential	1.5 mm. (max.)
Operating position (OP)	20.7±1.6 mm.