



Product Datasheet

ENGLISH

RS-Taper Bush, Size 1108



RS brand taper bushes permit easier and quicker fitting to drive shafts and are compatible with taper bush pulleys and sprockets. A four hole design ensures correct fitting and each bush is supplied with two grub screws and an installation guide.

Keyways are British Standard metric BS4235: Pt. 1: 1972 and conform to ISO recommendations. Where a key is to be used it should be parallel and side fitting with top clearance.. Depth keyways are measured at the centre



ENGLISH

Technical data:

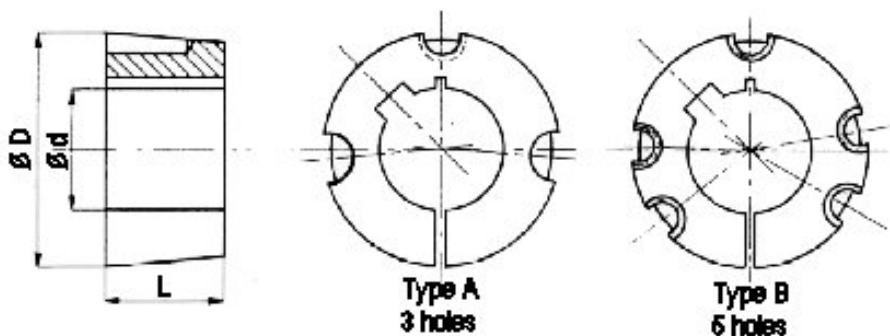

RS Stock	Size	Type	L (mm)	Ø D (mm)	Ø d (mm)	Grub screw / Cap head size (BSW)	Grub screw / Cap head torque (Nm)	Approx. weight (Kg)
0182997	1108	A	22	38	25	1/4" x 1/2"	5.6	0.12
0183007	1108	A	22	38	28	1/4" x 1/2"	5.6	0.12
0183748	1108	A	22	38	14	1/4" x 1/2"	5.6	0.12
0183754	1108	A	22	38	19	1/4" x 1/2"	5.6	0.12
0183760	1108	A	22	38	20	1/4" x 1/2"	5.6	0.12
0183776	1108	A	22	38	24	1/4" x 1/2"	5.6	0.12