

Switch-Pro™ LC1X

Compact Level Switch Controller



Application

The general purpose level controller is offered in two configurations for pump and valve control. The LC10 accepts one level sensor input and provides one 16A relay for high level control or low level control. The LC11 accepts two level sensor inputs and provides one latching 16A relay for automatic fill or empty control. The optional flash alarm brings attention to level alarm conditions. Package this level controller with our liquid level switch sensors and fittings.



Features

- Fail-safe relay control of pumps or valves with 0-60 second delay
- Optional strobe brings immediate attention to level alarm conditions
- PP enclosure rated NEMA 4X with swivel base for conduit alignment
- Easy setup with LED indicators for sensor, power and relay status
- Invert switch changes relay state from NO to NC without rewiring

Key Benefits

- Controls pumps, valves, horns and alarm indicators
- Mounts directly on Flowline level switches or fittings
- Corrosion resistant enclosure for indoor or outdoor use
- Complete solution for level switch control requirements



Compatible Products



LU10

SWITCH-TEK™

Ultrasonic Level Switch

Broadly applied in chemicals and light weight oils



LZ12

SWITCH-TEK™

Vibration Level Switch

Applied in wastewater with light coating or scaling



LV10

SWITCH-TEK™

Vertical Buoyancy Level Switch

Applied in clean water and non-coating chemicals

Switch-Pro™ LC1X

Compact Level Switch Controller



Specifications

Supply voltage:	120 / 240 VAC @ 50-60 Hz.
Consumption:	5 watts maximum
Sensor inputs:	LC10: (1) Two wire level switch LC11: (2) Two wire level switches
Sensor supply:	13.5 VDC @ 27 mA
LED indication:	Sensor, power & relay
Strobe type:	-10X1: N/A -10X2: Xenon tube
Strobe flash:	-10X1: N/A -10X2: 1 per second
Contact type:	LC10: (1) SPDT relay LC11: (1) SPDT latching relay
Contact rating:	250 VAC @ 16A
Contact output:	Selectable NO / NC
Contact delay:	0.15 - 60 seconds
Contact latch:	LC10: N/A LC11: Selectable ON/OFF
Ambient temp.:	F: -40° to 140° C: -40° to 60°
Pressure:	Atmospheric
Enclosure rating:	NEMA 4X (IP65)
Encl. material:	-10X1: PP, UL94VO -10X2: PP, UL94VO & PC
Conduit entrance:	1/2" NPT
Enclosure mount:	3/4" NPT (3/4" R)
Classification:	General purpose
Compliance:	CE
Approvals:	CSA, LR 79326

Dimensions

Without Strobe Alert

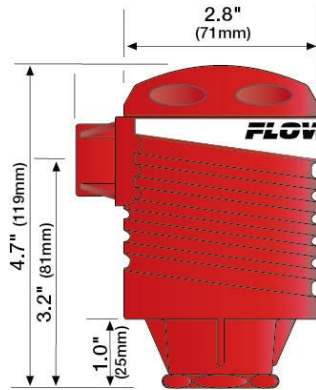

With Strobe Alert

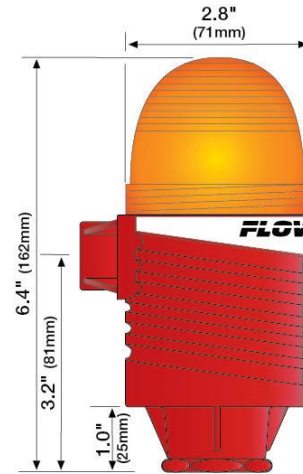

Strobe Alert

The Controller with Strobe Alert configuration flashes when the relay is energized during a high or low level alarm condition, bringing immediate visual attention.



Ordering

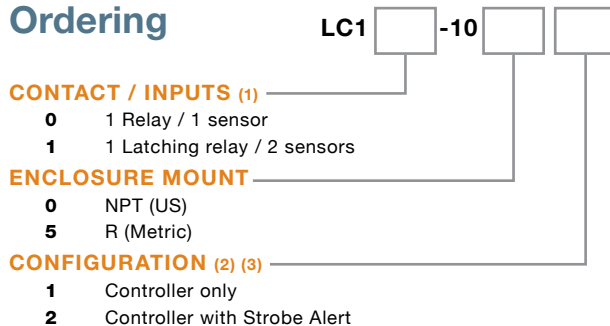

NOTES

- 1) The level controller is compatible with Flowline level switch sensors and installation fittings.
- 2) CE compliance is only available in the controller only configuration. Add -CE to the part number (i.e. LC10-1001-CE).
- 3) For 240 VAC versions, include a -E to the part number (i.e. LC0-1001-E).