

| REVISIONS | | | |
|-----------|-------------|------------|------|
| SYM | DESCRIPTION | REVISED BY | DATE |
| | | | |
| | | | |

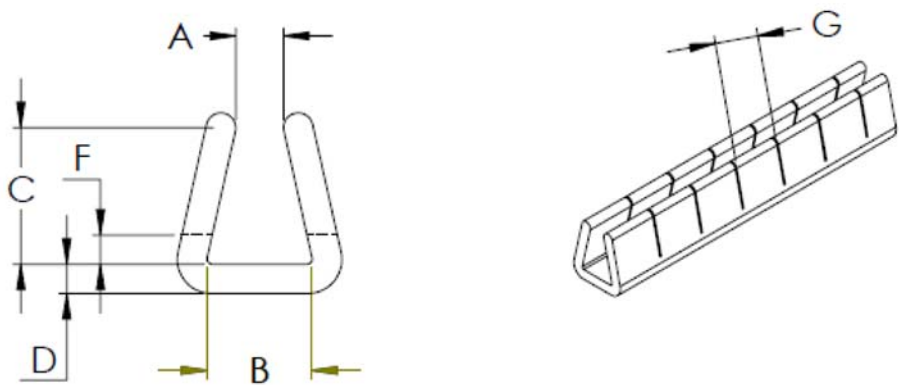

| PART NUMBER | PANEL THICKNESS | A | B | C | D | F | G |
|-------------|----------------------------|-----------------|-----------------|-----------------|-----------------|--------------------------------|----------------|
| 2692-100 | 0.036-0.062 (0.91-1.57) | 0.037 (0.94) | 0.109 (1.77) | 0.141 (3.58) | 0.031 (0.79) | 0.015 - 0.060 (0.38 - 1.52) | 0.156 (4.0) |
| 2693-100 | 0.062-0.099 (1.57-2.51) | 0.060 (1.52) | 0.109 (2.77) | | 0.031 (0.79) | 0.015 - 0.060 (0.38 - 1.52) | 0.156 (4.0) |
| 2694-100 | 0.099-0.144 (2.51-3.66) | 0.106 (2.69) | 0.156 (3.96) | | 0.047 (1.19) | 0.015 - 0.060 (0.38 - 1.52) | 0.156 (4.0) |

NOTE:
 1. ALL DIMENSIONS IN INCH(mm)
 2.
 3.

| | | | | | | | | | | | |
|---|--------|-------|------------------------------|--|--|---|-----------|-------|-----------------------------|--|----------|
| MATERIAL: POLYETHYLENE | | | FINISH: --- | | | <h1>ABBATRON</h1> <p>Electronic Connectors and Hardware</p> <p>13680 S. MOSIERTOWN RD MEADVILLE, PA 16335</p> | | | | | |
| DIMENSIONAL TOLERANCES UNLESS OTHERWISE SPECIFIED | | | TITLE: 2692,3,4-100 | | | | | | CATERPILLAR <u>GROMMETS</u> | | |
| .XX | .XXX | .XXXX | DRAWN: JJF DATE: 12/22/21 | | | | | | | | |
| ±.010 | ±.005 | --- | | | | | | | HEAT TREAT: | | CHECKED: |
| FRACTIONS | ANGLES | SCALE | PLOT SCALE: | | | APPROVED: | | DATE: | | | |
| ±1/64 | ±1° | | | | | B | SMP-00424 | | O | | |