

Part number

**CSHF 06**



Female insert, CSH series, SQUICH® spring terminal connection without tools, 6 poles + PE, 16 A 500 V 6 kV 3, size "44.27"

Product description	
<b>Product type</b>	Insert
<b>Series</b>	CSH
<b>Connection type</b>	SQUICH® spring terminal connection without tools
<b>Gender</b>	Female
<b>N. of poles</b>	6 poles + 
<b>Size</b>	Size "44.27"

Technical data	
<b>Current</b>	16 A
<b>Voltage</b>	500 V
<b>Rated impulse withstand voltage</b>	6 kV
<b>Pollution degree</b>	3
<b>Rated voltage according to UL/CSA</b>	600 V
<b>Wire cross-section</b>	0,14 mm <sup>2</sup> - 2,50 mm <sup>2</sup>
<b>AWG size</b>	26 - 14
<b>Contact type</b>	Turned silver plated
<b>IP degree of protection</b>	IP20 without enclosure, IP65/IP66/IP68/IP69 with enclosure

Further technical details	
<b>Characteristics according to EN 61984</b>	16A 500V 6kV 3; 16A 400/690V 6kV 2
<b>Mating cycles</b>	≥ 500
<b>Insulation resistance</b>	≥ 10 GΩ
<b>Contact resistance</b>	≤ 3 mΩ
<b>Weight</b>	50,50 g
<b>Operating temperature range (min, max)</b>	-40 °C ... +125 °C
<b>Conductors stripping length</b>	9...11 mm
<b>UL 94 flammability rating</b>	V-0
<b>Torque for main contact</b>	M3: 0.5 Nm; 4.4 lb.in (Ph0 or 0,8x4mm )
<b>Tightening torque for PE connection</b>	M4: 1,2 Nm, 10,6 lb.in (Ph2 or 1,0x5,5mm )
<b>Tightening torque for fixing screws</b>	M3: 0.5 Nm; 4.4 lb.in (Ph1 or 0.8x4 mm)

Material properties	
<b>Main material</b>	Polycarbonate (PC)
<b>Other materials</b>	Contacts: copper alloy
<b>Colour</b>	RAL 7032 grey
<b>RoHs conformity</b>	Compliant with exemption 6(c): copper alloy containing up to 4% lead by weight
<b>China RoHs - EFUP</b>	50
<b>REACH SVHC substances</b>	Yes Lead

Approvals / Standards	
<b>Reference standard</b>	EN 61984:2009-06
<b>Certifications</b>	CSA, CQC, DNV-GL, BV, EAC
<b>UL</b>	ECBT2, PVVA2
<b>cUL</b>	ECBT8, PVVA8

General ordering information	
<b>EAN13 code</b>	8015747080293
<b>eCl@ss 8.1</b>	27440205
<b>ETIM 7.0</b>	EC000438

Packaging Information	
<b>Packaging length</b>	245,00 mm
<b>Packaging height</b>	165,00 mm
<b>Packaging width</b>	215,00 mm
<b>Packaging weight</b>	3,53 kg
<b>Packaging volume</b>	8,69 dm <sup>3</sup>
<b>Packaging description</b>	Carton box
<b>Packaging quantity</b>	60 Pcs
<b>Packaging EAN code</b>	8015747170642
<b>Sub-packaging length</b>	197,00 mm
<b>Sub-packaging height</b>	44,00 mm
<b>Sub-packaging width</b>	113,00 mm
<b>Sub-packaging weight</b>	0,59 kg
<b>Sub-packaging volume</b>	0,98 dm <sup>3</sup>
<b>Sub-packaging description</b>	Carton tray
<b>Sub-packaging quantity</b>	10 Pcs
<b>Sub-packaging EAN barcode</b>	8015747170659

Part number  
**CSHF 06**



Catalogue drawings

Catalogue drawings

dimensions in mm

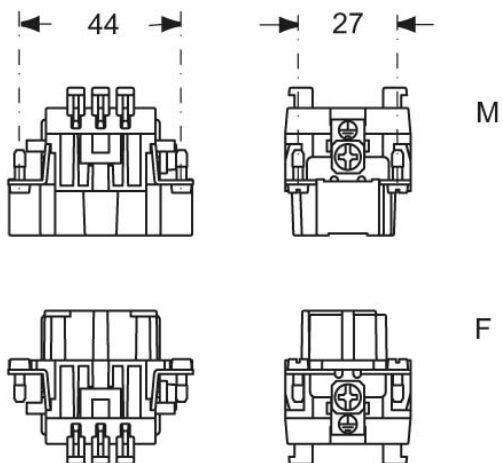

contacts side (front view)

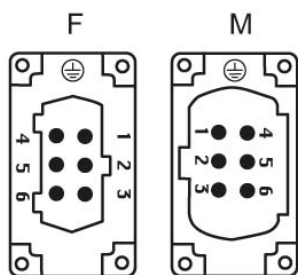

diagram CSH 06 poles

