

Technical Information

Memosens CPL51E

pH sensor for laboratory measurements and random sampling in the field



Digital with Memosens 2.0 technology
Robust pH sensor with plastic shaft

Application

Measurements in drinking water, wastewater and process water

Your benefits

- Simple to use, extremely versatile
- Physical protection of glass membrane
- Minimum risk of contamination thanks to open aperture diaphragm
- Fast response time even in cold, ion-weak water
- Integrated temperature sensor for automatic temperature compensation
- Suitable for use with Liquiline Mobile, Liquiline To Go and Memobase Plus

Other advantages of Memosens technology

- Maximum analysis safety with non-contact, inductive signal transmission
- Data security thanks to digital data transmission
- Very easy to use as sensor data saved in the sensor

Function and system design

Measuring principle

pH measurement

The pH value is used as a unit of measurement for the acidity or alkalinity of a medium. The membrane glass of the electrode delivers an electrochemical potential that depends on the pH value of the medium. This potential is generated by the selective accumulation of H^+ ions on the outer layer of the membrane. As a result, an electrochemical boundary layer with an electrical potential difference forms at this point. An integrated Ag/AgCl reference system serves as the required reference electrode.

The measured voltage is converted to the corresponding pH value using the Nernst equation.

Measuring system

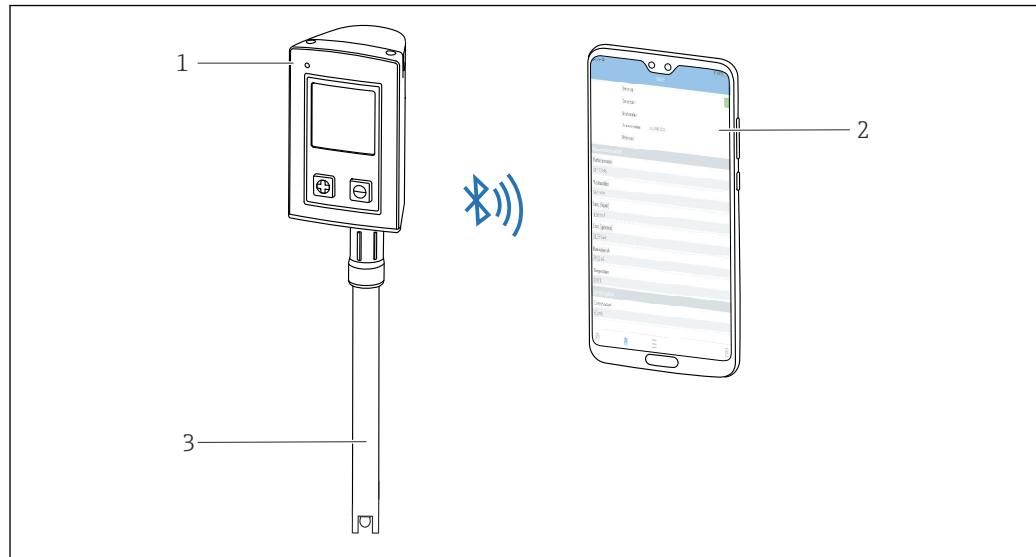

A0047842

1 Measuring system

- 1 Transmitter CML18
- 2 Smartphone with Smartblue app (optional)
- 3 Memosens CPL51E

Communication and data processing

Communication with the handheld device

i Always connect digital laboratory sensors with Memosens technology to a handheld device with Memosens technology, e.g. CML18.

Digital laboratory sensors can store measuring system data in the sensor, including:

- Manufacturer data
 - Serial number
 - Order code
 - Date of manufacture
- Calibration data
 - Calibration date
 - Number of calibrations
 - Serial number of the handheld device used to perform the last calibration or adjustment
- Application data
 - Temperature application range
 - pH application range
 - Date of initial commissioning

Input

Measured variable

pH value
Temperature

Measuring range

- pH value: 0 to 14 pH
- Temperature: 0 to 80 °C (32 to 176 °F)

Performance characteristics

Reference system Ag/AgCl lead, bridging electrolyte: gel KCl, 3M, AgCl-free

Environment

Ambient temperature range **NOTICE**
Risk of damage from frost!
▶ Do not use the sensor at temperatures below 0 °C (32 °F).

Storage temperature 0 to 50 °C (32 to 122 °F), non-freezing

Degree of protection IP 68 (10 m (33 ft) water column, 25 °C (77 °F), 45 days, 1 M KCl)

Electromagnetic compatibility (EMC) Interference emission and interference immunity as per EN 61326-1: 2013

Process

Process temperature range 0 to 80 °C (32 to 176 °F)

Mechanical construction

Design, dimensions

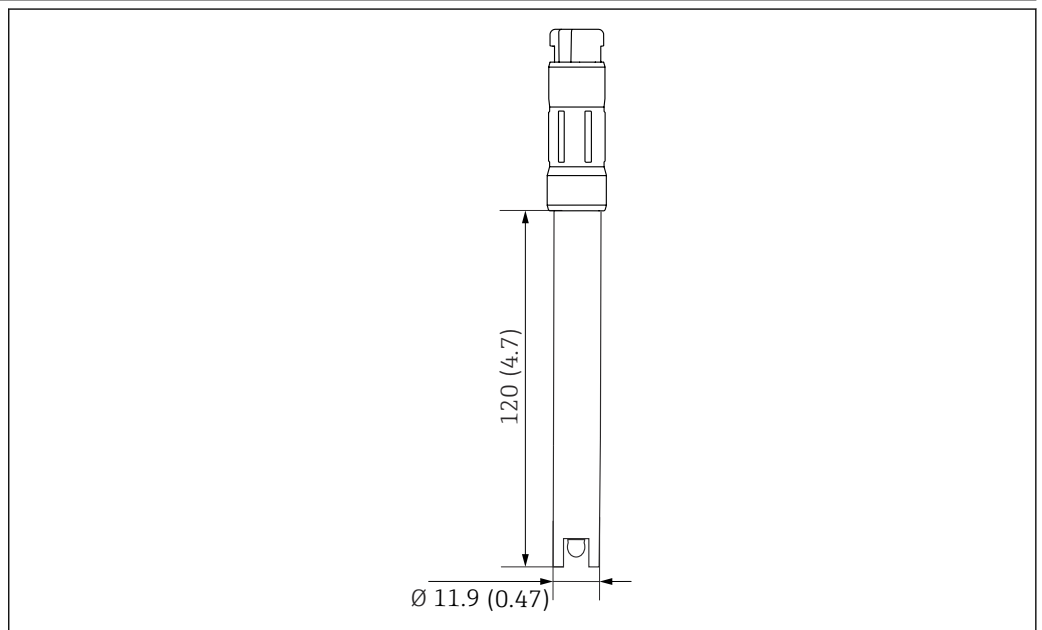

2 Engineering unit: mm (in)

A0047294

Weight	33 g (1.2 oz)	
Materials	Sensor shaft	PEEK
	Metal lead	Ag/AgCl
	Nameplate	Ceramic metal oxide
	Junction	Open junction
Temperature sensor	NTC 30K	
Plug-in head	Memosens laboratory plug-in head for digital, non-contact data transmission	
Process connections	Pg 13.5	

Accessories

The following are the most important accessories available at the time this documentation was issued.

- ▶ For accessories not listed here, please contact your Service or Sales Center.

Device-specific accessories

Memosens data cable CYK10

- For digital sensors with Memosens technology
- Product Configurator on the product page: www.endress.com/cyk10



Technical Information TI00118C

Memosens laboratory cable CYK20

- For digital sensors with Memosens technology
- Product Configurator on the product page: www.endress.com/cyk20

Liquiline Mobile CML18

- Multiparameter mobile device for laboratory and field
- Reliable transmitter with display and app connection
- Product Configurator on the product page: www.endress.com/CML18



Operating Instructions BA02002C

Memobase Plus CYZ71D

- PC software to support laboratory calibration
- Visualization and documentation of sensor management
- Sensor calibrations stored in database
- Product Configurator on the product page: www.endress.com/cyz71d



Technical Information TI00502C

High-quality buffer solutions from Endress+Hauser - CPY20

The secondary buffer solutions have been referenced to primary reference material of the PTB (German Federal Physico-technical Institute) or to standard reference material of NIST (National Institute of Standards and Technology) according to DIN 19266 by a laboratory accredited by the DAkkS (German accreditation body) according to DIN 17025.

Product Configurator on the product page: www.endress.com/cpy20



71557011

www.addresses.endress.com
