

JAND38999/32 PLUG CAPS

MIL-DTL-38999, Series III

Connector Group L

JAND38999/32	W	15	R
Designates Plug Dust Cover	FINISH	ACCESSORY SHELL SIZE	STYLE
	W: Aluminum Alloy 500 Hrs. Cadmium Olive Drab Z: Aluminum Alloy 500 Hrs. Black Zinc Nickel F: Aluminum Alloy 48 Hrs. Electroless Nickel	9 11 13 15 17 19 21 23 25	N: W/ SS Rope & Ring R: W/ SS Rope

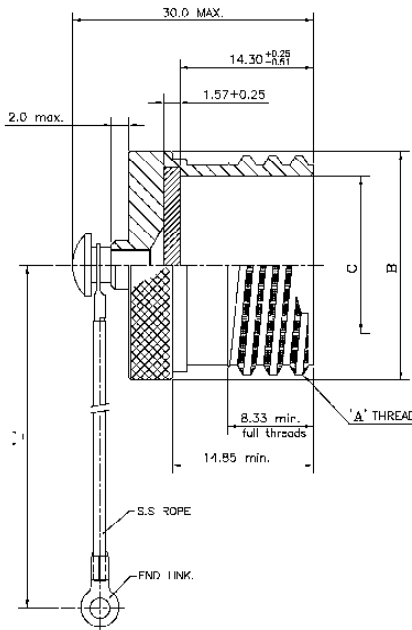

TABLE A

Accessory Shell Size	A Ø		B Ø Max.		C Ø Min.		D Ø Max.		E Ø Min.		F		L	
	mm	inch	mm	inch	mm	inch	mm	inch	mm	inch	mm	inch	mm	inch
9	15.74	0.62	17.20	0.67	12.50	0.49	24.00	0.94	13.00	0.51	24.00	14.50	127.00	5
11	19.05	0.75	20.50	0.80	15.75	0.62	27.00	1.06	18.00	0.70	20.50	18.00	127.00	5
13	22.09	0.87	24.30	0.95	19.53	0.76	30.00	1.18	20.00	0.78	27.00	20.00	127.00	5
15	25.4	1.00	27.40	1.07	22.71	0.89	31.00	1.22	23.00	0.90	22.50	18.00	127.00	5
17	29.97	1.18	30.60	1.20	25.88	1.018	37.00	1.45	26.00	1.02	30.50	23.50	127.00	5
19	31.75	1.25	33.25	1.30	28.55	1.12	40.00	1.57	29.00	1.14	31.50	23.50	127.00	5
21	34.79	1.37	36.40	1.43	31.72	1.248	44.00	1.73	32.00	1.25	33.00	26.50	127.00	5
23	38.1	1.50	39.70	1.56	34.90	1.37	46.00	1.81	34.00	1.33	34.00	26.50	127.00	5
25	41.14	1.62	42.80	1.68	38.07	1.49	49.00	1.92	39.00	1.53	38.00	30.00	127.00	5