

SW2015

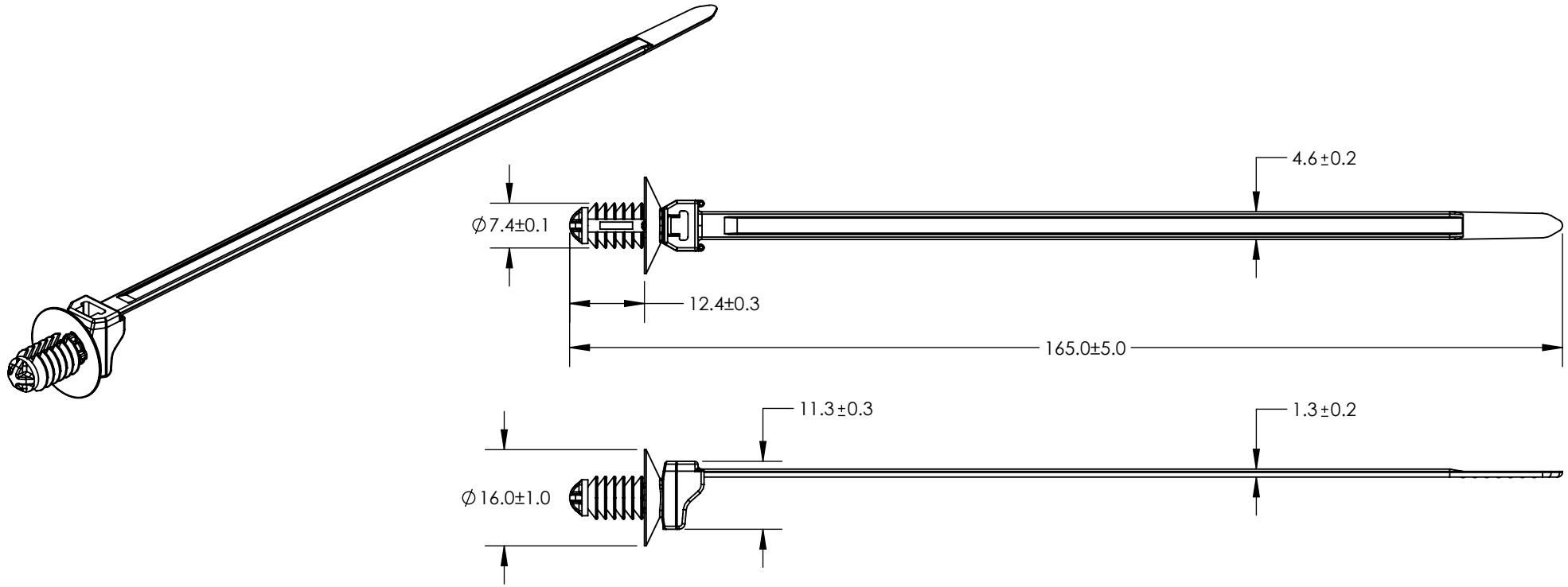

Revision level			Revision Record	Changed	Date	Approved	Date
Drawing	State	Part					
06.1	Design Release	-	SEE ECN# 013976	GAL	8/11/2017	SJA	8/11/2017



REFERENCE:

PERFORMANCE REQUIREMENTS:

1. FIR TREE PUSH IN FORCE: 45 NEWTONS (10LBS) MAX IN THE APPLICABLE NOMINAL HOLE SIZE AND A PLATE THICKNESS OF 1.8mm.
2. FIR TREE PULL OUT FORCE: 110 NEWTONS (25 LBS) MIN IN THE APPLICABLE NOMINAL HOLE SIZE AND A PLATE THICKNESS OF 1.8mm.
3. SHEET METAL THICKNESS RANGE: 0.70mm - 7.00mm
4. APPLICABLE HOLE SIZES:
A. 6.5mm +.5/- .2mm $\Delta_{0.1}$
5. CABLE TIE MIN. LOOP TENSILE STRENGTH: 225 NEWTONS (50 LBS) MIN
6. BUNDLE RANGE: 1.0mm TO 35.0mm
7. MAXIMUM PERCENT REGRIND PERMISSIBLE: 25%
8. MAX ALLOWABLE FLASH OR MISMATCH TO BE: 0.4mm

TYPE NUMBER	MATERIAL	COLOR
T50SOSFT6.5LG-E4X	PA66HS	BLACK
T50SOSFT6.5LG-E4X	PA66HS	NATURAL
T50SOSFT6.5LG-E4X	PA66HS	YELLOW
T50SOSFT6.5LG-E4X	PA66HIRHSUV	BLACK

Material SEE CHART	Units: millimeters	The copyright of this drawing is reserved by HellermannTyton. It is issued on condition that it is not reproduced, copied, or disclosed to a third party, either wholly or in part, without the consent of HellermannTyton.	Drawn	GAL	9/7/16	Article/Type-No SEE CHART	Scale	1:1	
	Dimension without tolerances details to: .XXX = ±.013 .XX = ±.13 .X = ±.3 None = ±.8 ∠ = ±0.5° Dimension Formatted mm/[in]		Approved	GGG	9/7/16		Title T50SOSFT6.5LG-E4X OUTSIDE SERRATED WITH 6.5mm FIR TREE	Project Number PRP 16-1353	
	HellermannTyton North America Email: corp@htamericas.com Web: www.hellermann.tyton.com			Drawing-No	16-1353-011-CSU		Production : Phase	Format AH	
				Sheet	1/1				