

SW2015

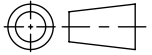

Revision level			Revision Record	Changed	Date	Approved	Date
Drawing	State	Part					
01.2	Design Release		SEE ECN# 013740	CAS	2/21/2018	KAC	2/21/2018

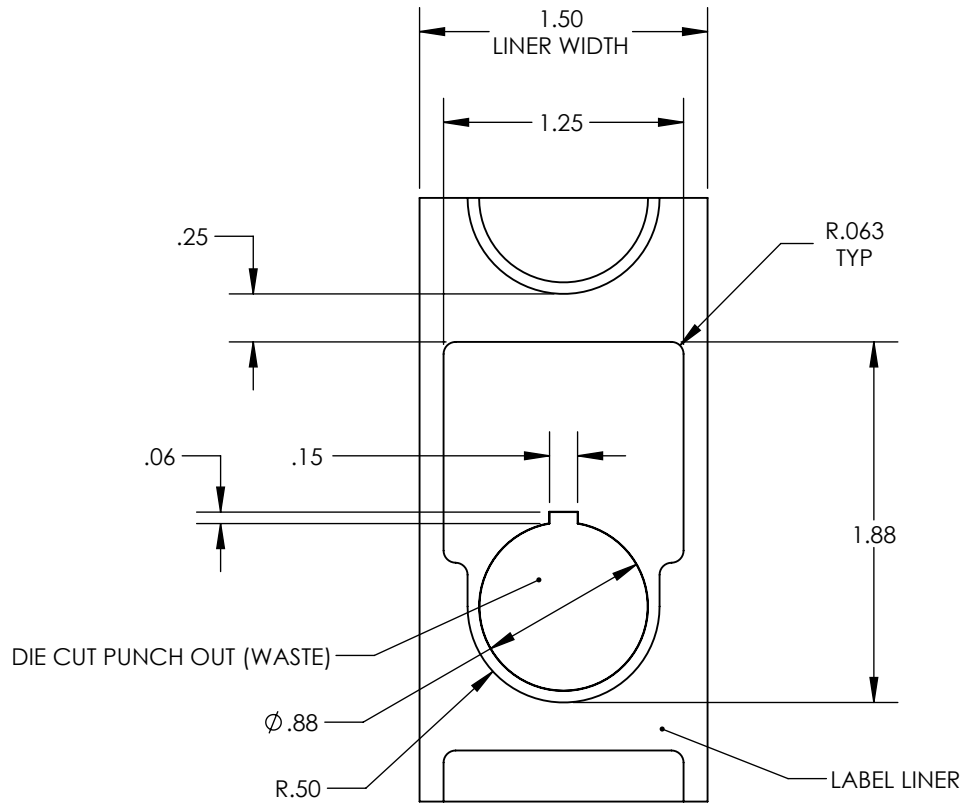

PART NUMBER DESCRIPTION

NPLH31X48\_22.5

COLOR \_\_\_\_\_  
(CONTACT FACTORY FOR AVAIL COLORS)

250 LABELS PER ROLL  
1 ACROSS ON A 3" CORE



NOTES:

- ADHESIVE: ACRYLIC
- ADHESIVE OPERATING TEMPERATURE: -40° F TO +176° F (-40° C TO +80° C)
- ROHS COMPLIANT

GLOBAL PART NUMBER	PART NUMBER	TYPE	COLOR
NPLH31X48WH22.5-PET-WH	596-00915	NPLH31X48WH22.5	WHITE
NPLH31X48BK22.5-PET-BK	596-00916	NPLH31X48BK22.5	BLACK

<b>Material</b> POLYESTER / POLYETHYLENE FOAM BASE	<b>Units: inches</b> Dimension without tolerances details to: .xxxx = ±.0005 .xxx = ±.005 .xx = ±.01 .x = ±.03 None = ±.06 < = ±0.5° Dimension Formatted in [mm]	The copyright of this drawing is reserved by HellermannTyton. It is issued on condition that it is not reproduced, copied, or disclosed to a third party, either wholly or in part, without the consent of HellermannTyton.	Drawn GRW 3/2/2017	Article/Type-No NPL31X48_22.5	Scale
	Approved KAC 3/2/2017		Title <b>FOAM BUTTON NAMEPLATE</b>	Project Number PRP 17-0704	
	<b>HellermannTyton</b> North America Email: corp@htamericas.com Web: www.hellermann.tyton.com		Drawing-No <b>17-0704-001-CSU</b>	PRODUCTION : Phase Format AH	
			Sheet 1/1		