

JANMS3181 PROTECTIVE RECEPTACLE CAPS

MIL-DTL-26482

Connector Group J

JANMS3181	10	C	A	L
Designates Receptacle Dust Cover	ACCESSORY SHELL SIZE	STYLE	FINISH	LENGTH
	8 10 12 14 16 18 20 22 24	C: W/ Chain N: W/ Chain & Ring R: W/ SS Rope	A: Anodized Black K: Black Zinc Nickel L: Electroless Nickel W: Cadmium	L: 5 in. Chain /Rope in lieu of standard length (Omit for st. length "H")

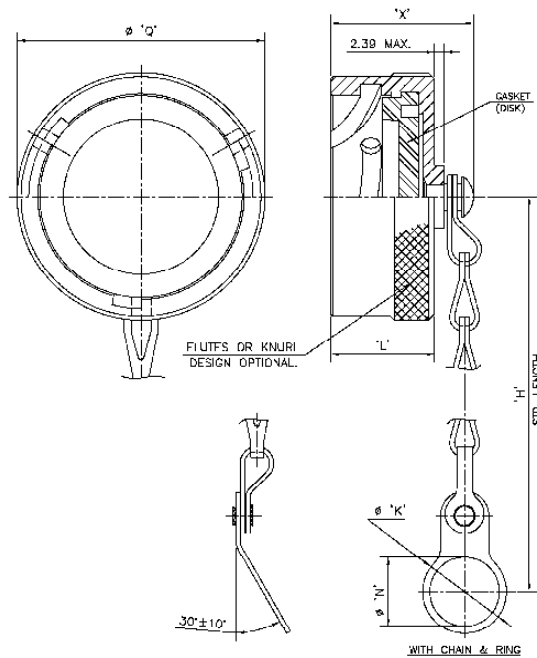

TABLE A

Accessory Shell Size	K Ø Max. Length		L Max.		Q Ø Max. Overall		H Std. Length		N Ø Min.		X Max. Overall	
	mm	inch	mm	inch	mm	inch	+12.70 / -6.35		mm	inch	mm	inch
							mm	inch				
8	20.62	0.81	14.27	0.56	18.64	0.73	76.20	3	14.68	0.57	21.44	0.84
10	25.4	1	14.27	0.56	21.82	0.85	76.20	3	17.86	0.70	21.44	0.84
12	30.18	1.18	14.27	0.56	25.40	1	88.90	3.5	22.63	0.89	21.44	0.84
14	36.53	1.43	14.27	0.56	28.58	1.12	88.90	3.5	25.81	1.01	21.44	0.84
16	39.67	1.56	14.27	0.56	31.75	1.25	88.90	3.5	28.98	1.14	21.44	0.84
18	42.88	1.68	14.27	0.56	34.92	1.37	88.90	3.5	32.16	1.26	21.44	0.84
20	47.55	1.87	14.27	0.56	38.10	1.5	101.60	4	35.33	1.39	21.44	0.84
22	49.23	1.93	14.27	0.56	41.28	1.62	101.60	4	38.51	1.51	21.44	0.84
24	52.37	2.06	15.29	0.6	44.45	1.75	101.60	4	41.68	1.64	22.22	0.87