

**Product Specification**

---

# NHD-3.5-320240FT-CSXP-T

## EVE2 TFT Module

<b>NHD-</b>	Newhaven Display
<b>3.5-</b>	3.5" Diagonal
<b>320240-</b>	320x240 Pixel Resolution
<b>FT-</b>	Model
<b>C-</b>	On-board Controller
<b>S-</b>	Sunlight Readable
<b>X-</b>	TFT
<b>P-</b>	IPS
<b>T-</b>	Resistive Touch Panel

## Table of Contents

Document Revision History.....	3
Mechanical Drawing .....	4
Schematic.....	5
Pin Description .....	6
Controller Information.....	6
Display Information .....	6
Arduino Application.....	6
Electrical Characteristics .....	7
Optical Characteristics .....	7
Touch Panel Characteristics .....	7
Backlight Driver Configuration .....	7
FT81x Block Diagram .....	8
Serial Host Interface .....	8
TFT Timing Characteristics .....	9
Graphics Engine .....	9
Touch-Screen Engine .....	10
Audio Engine .....	10
Audio Filter and Amplifier Reference Circuit.....	11
Additional Information/Resources .....	12
Quality Information .....	13

---

## Additional Resources

- **Support Forum:** <https://support.newhavendisplay.com/hc/en-us/community/topics>
- **GitHub:** <https://github.com/newhavendisplay>
- **Example Code:** <https://support.newhavendisplay.com/hc/en-us/categories/4409527834135-Example-Code/>
- **Knowledge Center:** [https://www.newhavendisplay.com/knowledge\\_center.html](https://www.newhavendisplay.com/knowledge_center.html)
- **Quality Center:** [https://www.newhavendisplay.com/quality\\_center.html](https://www.newhavendisplay.com/quality_center.html)
- **Precautions for using LCDs/LCMs:** <https://www.newhavendisplay.com/specs/precautions.pdf>
- **Warranty / Terms & Conditions:** <https://www.newhavendisplay.com/terms.html>



## Document Revision History

Revision	Date	Description	Changed By
0	05/25/2022	Initial Release	ZP
1	08/30/2022	Updated Backlight PWM Frequency Range, Updated Schematic to show new LED driver IC and auxiliary components	TM

# Mechanical Drawing

SYMBOL	REVISION	DATE

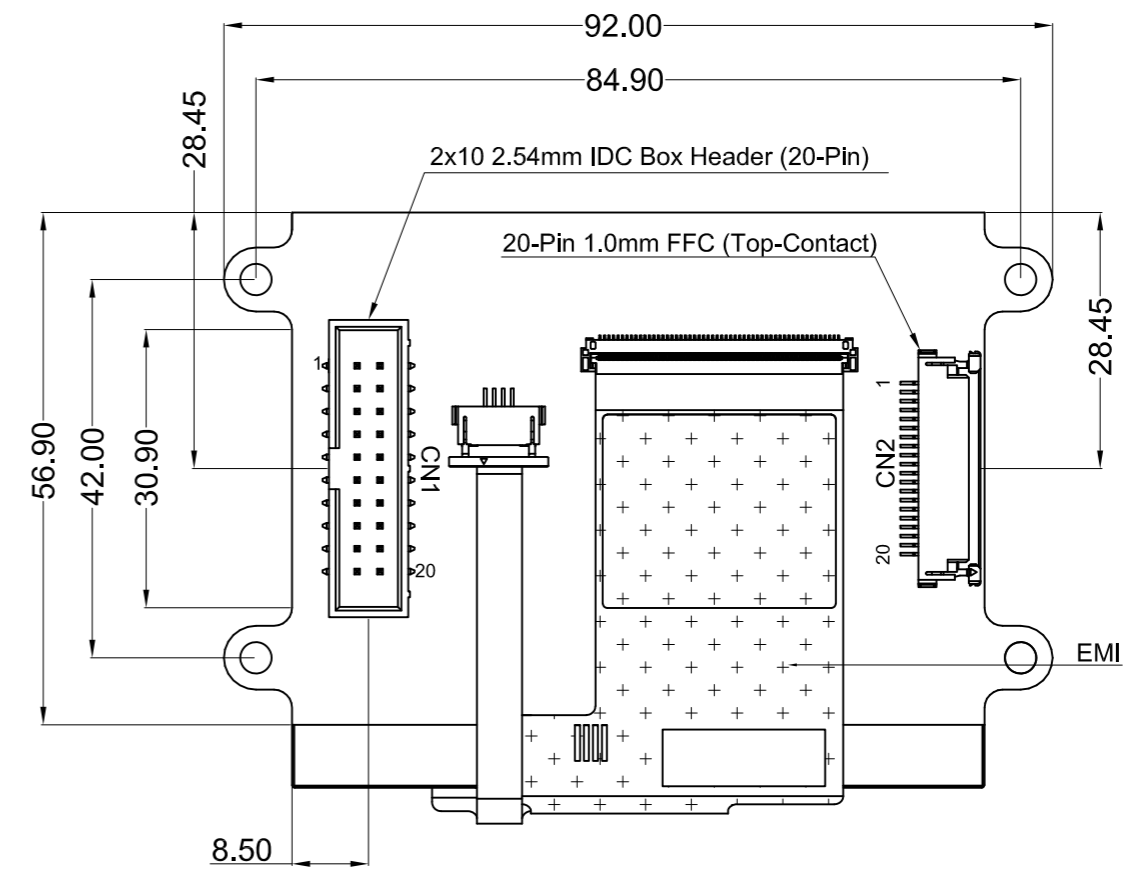
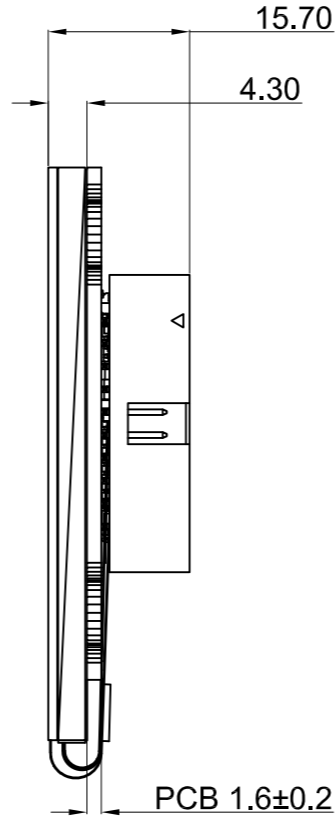
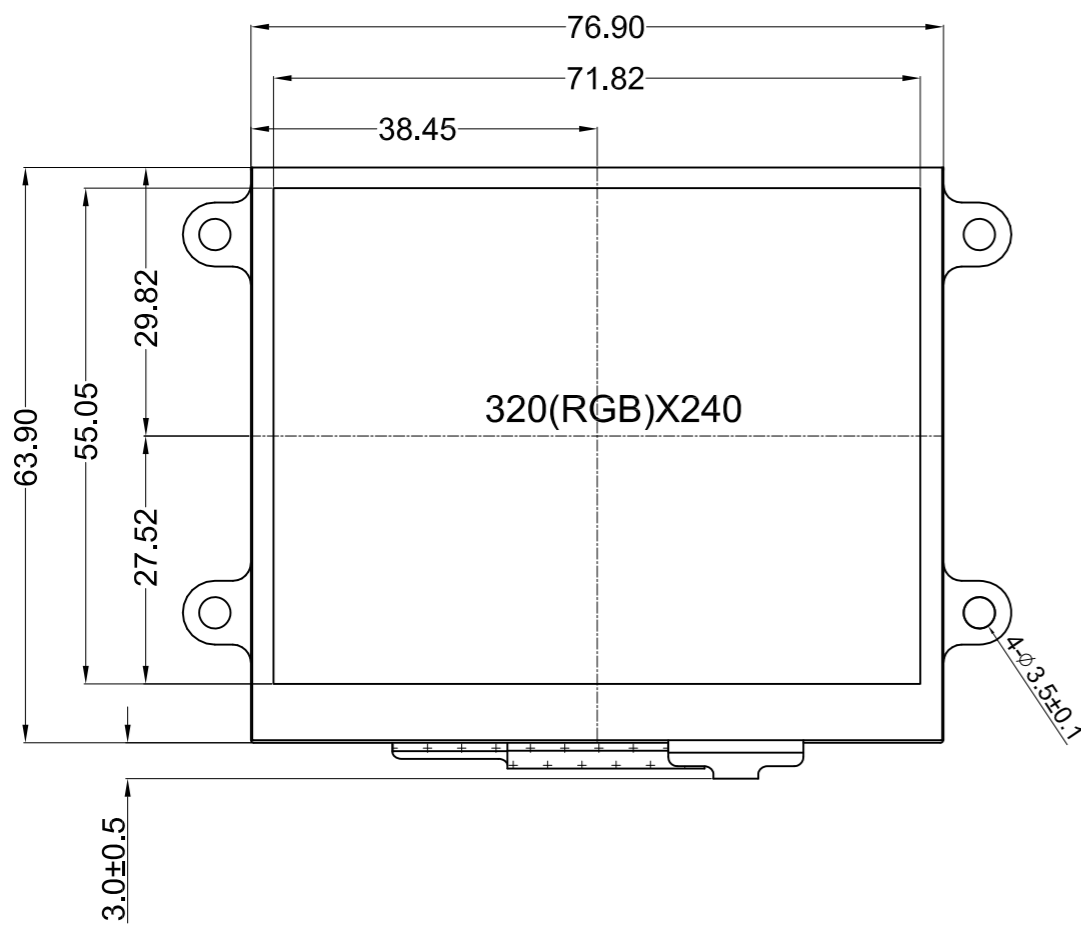

Pin Assignment	
NO.	Symbol
1	VDD
2	GND
3	SCK
4	MISO/IO1
5	MOSI/IO0
6	/CS
7	/INT
8	/PD
9	AUDIO_L
10	NC
11	GPIO0/IO2
12	GPIO1/IO3
13	GPIO2
14	GPIO3
15	NC
16	NC
17	VBL
18	VBL
19	GND
20	GND

- Product Description: 3.5" IPS EVE2 TFT w/Resistive Touch
- EVE2 Driver IC: FT812
  - EVE2 Interface: SPI, D-SPI, Q-SPI
  - EVE2 Power Requirement: 3.3V, Backlight: 280mA (3.3V Reference)
  - Optical Features: Normally Black, Transmissive, 900 cd/m<sup>2</sup>
  - Male IDC Box Header: 20pin(2x10), 2.54mm pitch
  - FFC Connector: 20pin, 1.0mm pitch
  - Key Features: EMI Shielding on TFT FPC

<b>Standard Tolerance:</b> (Unless otherwise specified)  Linear: ±0.3mm		
	Drawing/Part Number: <b>NHD-3.5-320240FT-CSXP-T</b>	Revision: -
<b>Unless otherwise specified:</b> • Dimensions are in Millimeters • Third Angle Projection	Drawn By: Z.Palrang	Approved By: Z.Palrang
	Drawn Date: 05/25/2022	Approved Date: 05/25/2022
<b>Do Not Scale Drawing</b>		Sheet 1 of 1
This drawing is solely the property of Newhaven Display International, Inc. The information it contains is not to be disclosed, reproduced or copied in whole or part without written approval from Newhaven Display.		

20-Pin 1.0mm FFC (Bottom Contact)

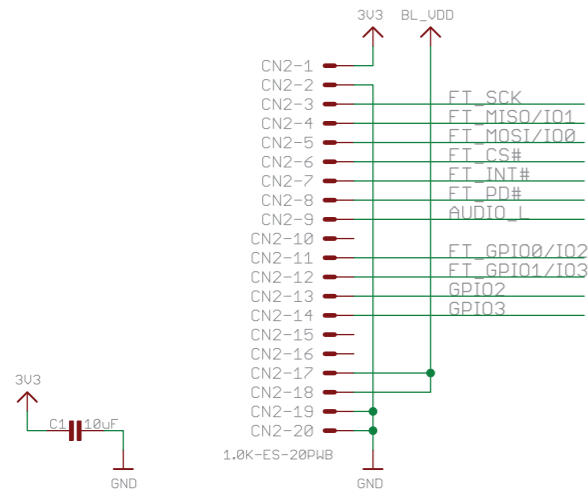

FTDI FT812Q (24 bit RGB Resistive Touch)

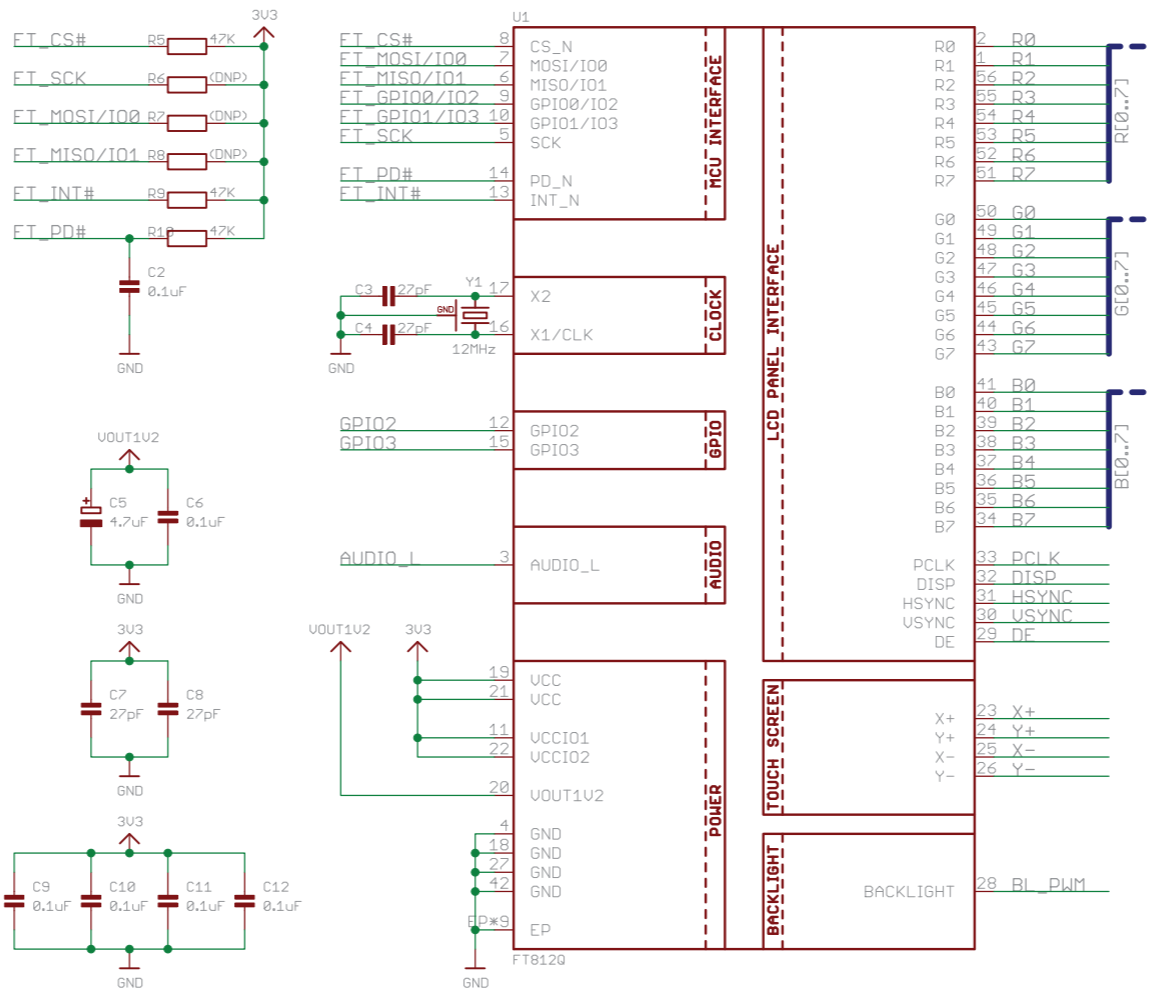

LCD Interface

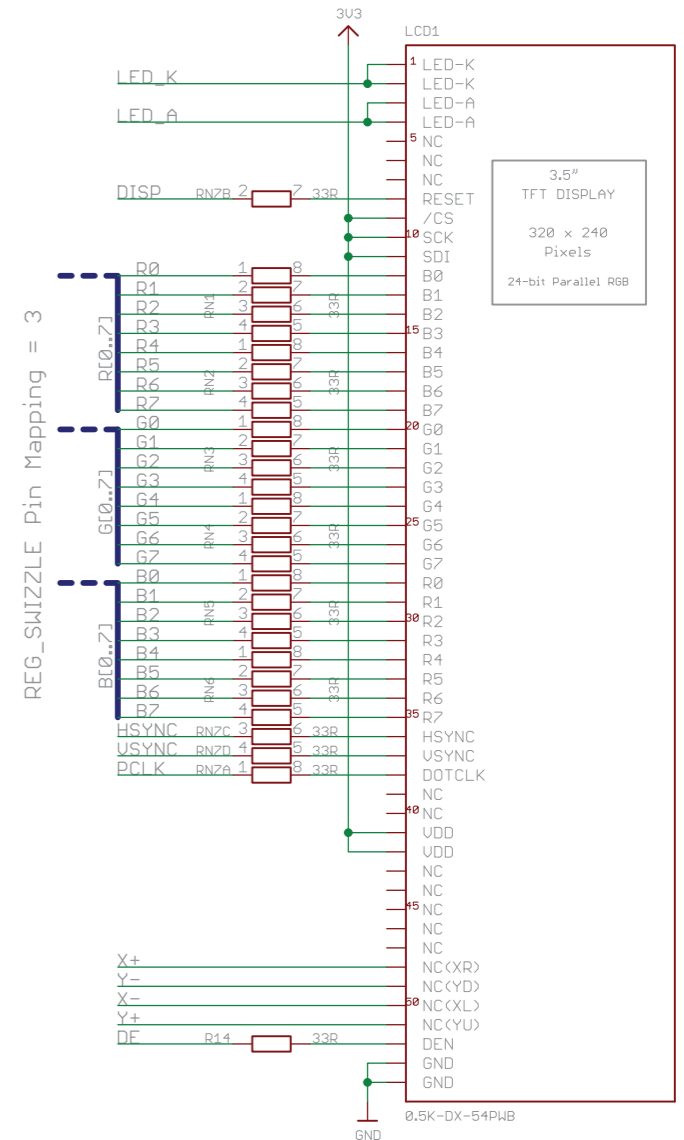

2x10 2.54mm IDC Box Header (20 Pin)

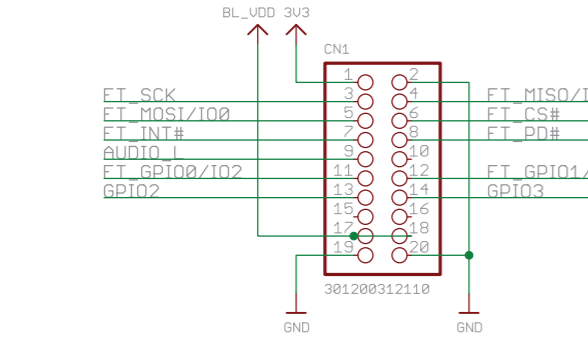

Exposed Pads to Ground TFT Bezel

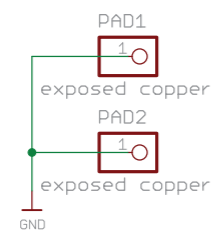

Backlight

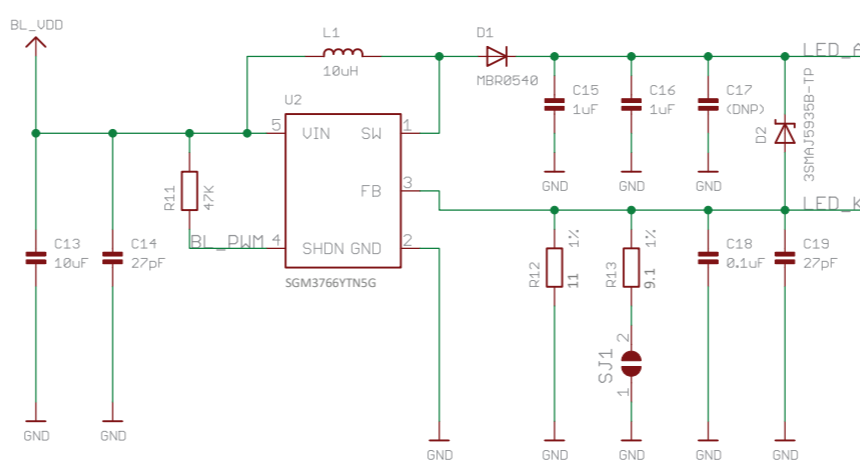

Backlight Configuration		
Current	SJ1	Display
~18mA	Open	ATXL#
~40mA	Close	ASXU#, ASXN#, ASXP

Mounting Holes 3.5mm Plated

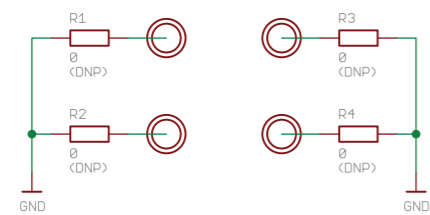

**NEWHAVEN DISPLAY INTERNATIONAL**

SCHEMATIC/PART NUMBER: **NHD-3.5R-FT812 Controller Board**

REVISION: -

SIZE: A3

DRAWN BY: C. Johnson      CHECKED BY: C. Johnson

DRAWN DATE: 08/26/2022      CHECKED DATE: 08/26/2022

SHEET: 1 of 1

Released under the Creative Commons Attribution Share-Alike 4.0 License <http://creativecommons.org/licenses/by-sa/4.0>

open source hardware

## Pin Description

Pin No.	Symbol	External Connection	Function Description
1	VDD	Power Supply	Input Voltage for TFT and FT81x (3.3V)
2	GND	Power Supply	Ground
3	SCK	MCU	SPI Clock (Input)
4	MISO/IO1	MCU	SPI MISO (Output) / Quad-SPI mode: SPI data line 1
5	MOSI/IO0	MCU	SPI MOSI (Input) / Quad-SPI mode: SPI data line 0
6	/CS	MCU	SPI Chip Select (Input), Active LOW
7	/INT	MCU	Interrupt to host (Output), Active LOW
8	/PD	MCU	Power Down control (Input), Active LOW
9	AUDIO_L	Filter/Amplifier	Audio PWM out (Output)
10	N.C.	-	No Connect
11	GPIO0/IO2	MCU	General Purpose IO0 / SPI Quad mode: SPI data line 2
12	GPIO1/IO3	MCU	General Purpose IO1 / SPI Quad mode: SPI data line 3
13	GPIO2	MCU	General Purpose IO2
14	GPIO3	MCU	General Purpose IO3
15 - 16	N.C.	-	No Connect
17 - 18	VBL	Power Supply	Input Voltage for LED Backlight Driver (3.3V/5V)
19 - 20	GND	Power Supply	Ground

**CN1:** Male IDC Box Header - 20-Pin, 2x10, 2.54mm pitch.

**CN2:** FFC Connector - 20-Pin, 1.0mm pitch, Top-contact.

**NOTICE:** It is not recommended to apply power to the board without a display connected. Doing so may result in a damaged LED driver circuit. Newhaven Display does not assume responsibility for failures due to this damage.

## Controller Information

This EVE2 TFT Module is powered by the FTDI/Bridgetek FT812 Embedded Video Engine (EVE2).

To view the full FT81x specification, please download it by accessing the link below:

<https://support.newhavendisplay.com/hc/en-us/articles/6963170802839-FT81x>

## Display Information

Part Number	Display Type	Luminance Rating	Viewing Angle	Interface
NHD-3.5-320240JF-ASXP-T	IPS	900 cd/m <sup>2</sup>	Full View	24-Bit RGB

This product consists of the above TFT display assembled with a PCB which supports all the features of this module. For more details on the TFT display itself, please download the specification at:

<https://newhavendisplay.com/content/specs/NHD-3.5-320240JF-ASXP-T.pdf>

## Arduino Application

If using or prototyping this EVE2 TFT Module with the low-cost, widely popular Arduino platform we highly recommend using our Arduino shield, the NHD-FT81x-SHIELD. Not only does the NHD-FT81x-SHIELD provide seamless connectivity and direct software compatibility for the user, but it also comes with the following useful features on-board:

- logic level shifters to allow the 5V Arduino to communicate with the 3.3V FT81x
- regulators to allow the Arduino to output more current to the EVE2 TFT Module
- audio filter/amplifier circuit to utilize the EVE2 TFT Module's audio output signal
- microSD card slot, which allows expandable storage for data such as images, video, and audio to be stored.

Please visit the NHD-FT81x-SHIELD product webpage for more info.



## Electrical Characteristics

Item	Symbol	Condition	Min.	Typ.	Max.	Unit
Operating Temperature Range	T <sub>OP</sub>	Absolute Max	-20	-	+70	°C
Storage Temperature Range	T <sub>ST</sub>	Absolute Max	-30	-	+80	°C
Supply Voltage	V <sub>DD</sub>	-	3.0	3.3	3.6	V
Supply Current	I <sub>DD</sub>	V <sub>DD</sub> = 3.3V	-	40	-	mA
"H" Level Input	V <sub>IH</sub>	-	0.7*V <sub>DD</sub>	-	V <sub>DD</sub>	V
"L" Level Input	V <sub>IL</sub>	-	V <sub>SS</sub>	-	0.3*V <sub>DD</sub>	V
"H" Level Output	V <sub>OH</sub>	-	V <sub>DD</sub> -0.4	-	V <sub>DD</sub>	V
"L" Level Output	V <sub>OL</sub>	-	V <sub>SS</sub>	-	V <sub>SS</sub> +0.4	V
Supply Voltage for LED Backlight Driver	V <sub>BL</sub>	-	2.8	3.3	5.5	V
Supply Current for LED Backlight Driver	I <sub>BL</sub>	V <sub>BL</sub> = 3.3V	-	280	-	mA
	I <sub>BL</sub>	V <sub>BL</sub> = 5.0V	-	170	-	mA
Backlight PWM Frequency	f <sub>PWM</sub>	-	800	-	10,000	Hz

## Optical Characteristics

Item		Symbol	Condition	Min.	Typ.	Max.	Unit
Optimal Viewing Angles	Top	φY+	CR ≥ 10	70	80	-	°
	Bottom	φY-		70	80	-	°
	Left	θX-		70	80	-	°
	Right	θX+		70	80	-	°
Contrast Ratio		CR	-	640	800	-	-
Luminance		L <sub>V</sub>	-	600	900	-	cd/m <sup>2</sup>
Response Time	Rise	T <sub>r</sub>	T <sub>OP</sub> = 25° C	-	30	40	ms
	Fall	T <sub>f</sub>		-	30	40	ms

## Touch Panel Characteristics

Item	Min.	Typ.	Max.	Unit
Linearity	-	-	1.5	%
Transmittance	75	-	-	%
Activation Force	20	-	80	g
Pen Writing Durability	20,000	-	-	Characters
Pitting Durability	1,000,000	-	-	Touches
Surface Hardness	3	-	-	H

## Backlight Driver Configuration

The Backlight Driver Enable signal is connected to the FT81x backlight control pin. This signal is controlled by two registers: REG\_PWM\_HZ and REG\_PWM\_DUTY. **REG\_PWM\_HZ** specifies the PWM output frequency – the range available on the FT81x is 250 to 10KHz and the on-board backlight driver's PWM frequency is 800 to 100KHz. Therefore, for proper use of the PWM function available on this module, the PWM frequency should not go below 800 or exceed 10KHz.

**REG\_PWM\_DUTY** specifies the duty cycle – the range is 0 to 128. A value of 0 turns the backlight completely off, while a value of 128 provides maximum backlight brightness.

For the above register definitions, please refer to pages 80-81 of the official FT81x Series Programmers Guide: [http://www.ftdichip.com/Support/Documents/ProgramGuides/FT81X\\_Series\\_Programmer\\_Guide.pdf](http://www.ftdichip.com/Support/Documents/ProgramGuides/FT81X_Series_Programmer_Guide.pdf)





## FT81x Block Diagram

FT81x with EVE (Embedded Video Engine) technology simplifies the system architecture for advanced Human Machine Interfaces (HMIs) by providing support for display, touch, and audio as well as an object-oriented architecture approach that extends from display creation to the rendering of the graphics.

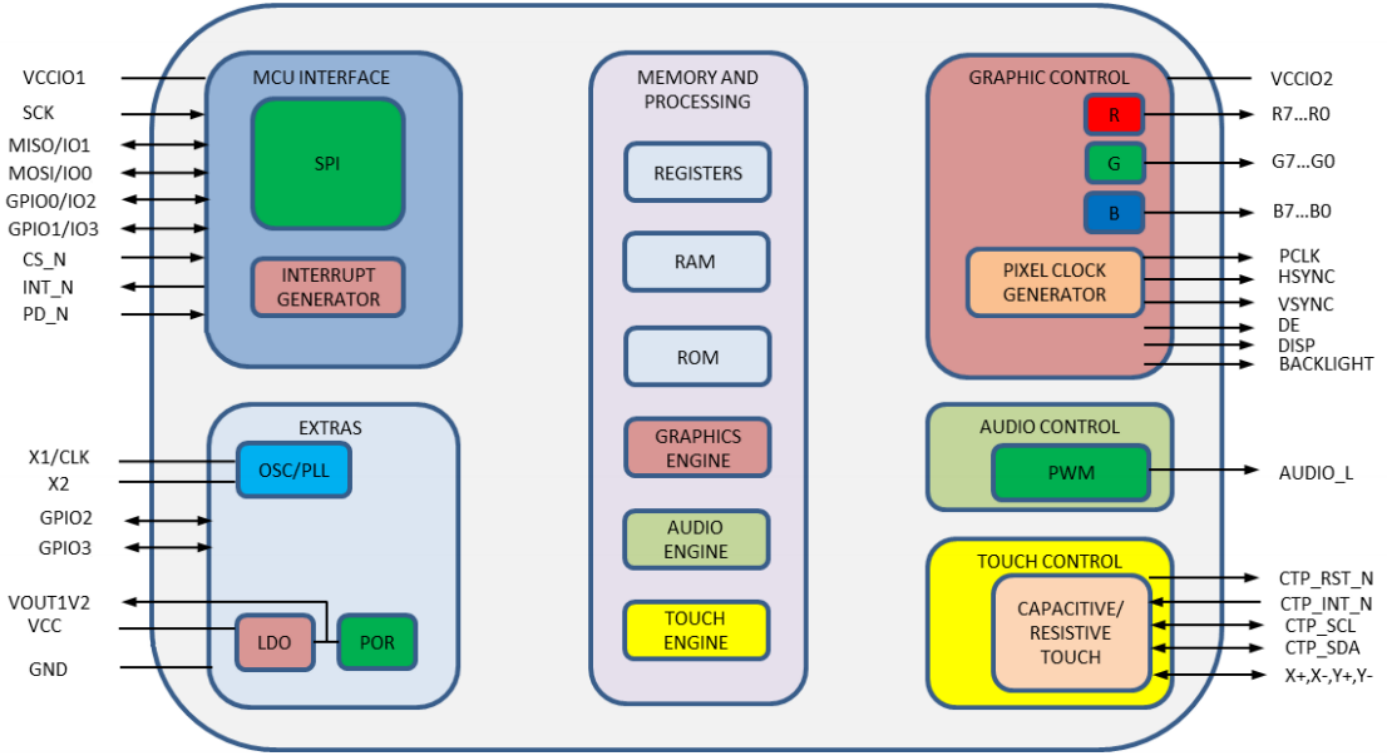

## Serial Host Interface

By default the SPI slave operates in the SINGLE channel mode with MOSI as input from the master and MISO as output to the master. DUAL and QUAD channel modes can be configured through the SPI slave itself. To change the channel modes, write to register REG\_SPI\_WIDTH. Please refer to the table below:

REG_SPI_WIDTH[1:0]	Channel Mode	Data Pins	Max Bus Speed
00	SINGLE (default)	MISO, MOSI	30MHz
01	DUAL	IO0, IO1	30MHz
10	QUAD	IO0, IO1, IO2, IO3	25MHz
11	Reserved	-	-

For more details on the FT81x SPI interface, please refer to pages 13-15 of the official FT81x Datasheet:  
<https://support.newhavendisplay.com/hc/en-us/articles/6963170802839-FT81x>

For the REG\_SPI\_WIDTH register definition, please refer to page 87 of the official FT81x Series Programmers Guide:  
[http://www.ftdichip.com/Support/Documents/ProgramGuides/FT81X\\_Series\\_Programmer\\_Guide.pdf](http://www.ftdichip.com/Support/Documents/ProgramGuides/FT81X_Series_Programmer_Guide.pdf)

## TFT Timing Characteristics

Shown below are the FT81x registers that control the TFT's timing (clock and sync signals), along with the values recommended to use for this EVE2 TFT Module:

### Horizontal Timing

Register	Value
REG_HSIZE	320
REG_HCYCLE	408
REG_HOFFSET	70
REG_HSYNC0	0
REG_HSYNC1	10

### Vertical Timing

Register	Value
REG_VSIZE	240
REG_VCYCLE	263
REG_VOFFSET	13
REG_VSYNC0	0
REG_VSYNC1	2

### Clock Settings

Register	Value
REG_PCLK	8
REG_SWIZZLE	2
REG_PCLK_POL	0
REG_CSPREAD	0
REG_DITHER	0

## Graphics Engine

The graphics engine executes the display list once for every horizontal line. It executes the primitive objects in the display list and constructs the display line buffer. The horizontal pixel content in the line buffer is updated if the object is visible at the horizontal line.

Main features of the graphics engine are:

- The primitive objects supported by the graphics processor are: lines, points, rectangles, bitmaps (comprehensive set of formats), text display, plotting bar graph, edge strips, and line strips, etc.
- Operations such as stencil test, alpha blending and masking are useful for creating a rich set of effects such as shadows, transitions, reveals, fades, and wipes.
- Anti-aliasing of the primitive objects (except bitmaps) gives a smoothing effect to the viewer.
- Bitmap transformations enable operations such as translate, scale, and rotate.
- Display pixels are plotted with 1/16th pixel precision.
- Four levels of graphics states
- Tag buffer detection

The graphics engine also supports customized built-in widgets and functionalities such as jpeg decode, screen saver, calibration etc. The graphics engine interprets commands from the MPU host via a 4 Kbyte FIFO in the FT81x memory at RAM\_CMD. The MPU/MCU writes commands into the FIFO, and the graphics engine reads and executes the commands. The MPU/MCU updates the register REG\_CMD\_WRITE to indicate that there are new commands in the FIFO, and the graphics engine updates REG\_CMD\_READ after commands have been executed.

Main features supported are:

- Drawing of widgets such as buttons, clock, keys, gauges, text displays, progress bars, sliders, toggle switches, dials, gradients, etc.
- JPEG and motion-JPEG decode
- Inflate functionality (zlib inflate is supported)
- Timed interrupt (generate an interrupt to the host processor after a specified number of milliseconds)
- In-built animated functionalities such as displaying logo, calibration, spinner, screen saver and sketch
- Snapshot feature to capture the current graphics display

For a complete list of graphics engine display commands and widgets, please refer to Chapter 4 of the official **FT81x Series Programmers Guide**:

[http://www.ftdichip.com/Support/Documents/ProgramGuides/FT81X\\_Series\\_Programmer\\_Guide.pdf](http://www.ftdichip.com/Support/Documents/ProgramGuides/FT81X_Series_Programmer_Guide.pdf)



## Touch-Screen Engine

The resistive touchscreen consists of a Touch-Screen Engine, ADC, Axis-switches, and ADC input multiplexer. The Touch-Screen Engine reads commands from the memory map register and generates the required control signals to the axis-switches and inputs mux and ADC. The ADC data are acquired, processed, and updated in the respective register for the MPU/MCU to read.

For more details on the FT812 Touch-Screen Engine, please refer to pages 32-33 of the official FT81x Datasheet: <https://support.newhavendisplay.com/hc/en-us/articles/6963170802839-FT81x>

## Audio Engine

The FT81x provides mono audio output through a PWM output pin, AUDIO\_L. It outputs two audio sources, the sound synthesizer and audio file playback.

This pin is designed to be passed into a simple filter circuit and then passed to an amplifier for best results. Please refer to the example schematic in the Audio Filter and Amplifier Reference Circuit section on the next page.

### Sound Synthesizer

A sound processor, AUDIO ENGINE, generates the sound effects from a small ROM library of waves table. To play a sound effect listed in Table 4.3, load the REG\_SOUND register with a code value and write 1 to the REG\_PLAY register. The REG\_PLAY register reads 1 while the effect is playing and returns a '0' when the effect ends. Some sound effects play continuously until interrupted or instructed to play the next sound effect. To interrupt an effect, write a new value to REG\_SOUND and REG\_PLAY registers; e.g. write 0 (Silence) to REG\_SOUND and 1 to PEG\_PLAY to stop the sound effect.

The sound volume is controlled by register REG\_VOL\_SOUND. The 16-bit REG\_SOUND register takes an 8-bit sound in the low byte. For some sounds, marked "pitch adjust" in the table below, the high 8 bits contain a MIDI note value. For these sounds, a note value of zero indicates middle C. For other sounds the high byte of REG\_SOUND is ignored.

### Audio Playback

The FT81x can play back recorded sound through its audio output. To do this, load the original sound data into the FT81x's RAM, and set registers to start the playback. The registers controlling audio playback are:

REG_PLAYBACK_START:	The start address of the audio data.
REG_PLAYBACK_LENGTH:	The length of the audio data, in bytes.
REG_PLAYBACK_FREQ:	The playback sampling frequency, in Hz.
REG_PLAYBACK_FORMAT:	The playback format, one of LINEAR SAMPLES, uLAW SAMPLES, or ADPCM SAMPLES.
REG_PLAYBACK_LOOP:	If '0', the sample is played once. If '1', the sample is repeated indefinitely.
REG_PLAYBACK_PLAY:	A write to this location triggers the start of audio playback, regardless of writing '0' or '1'. Read back '1' when playback is ongoing, and '0' when playback finishes.
REG_VOL_PB:	Playback volume, 0-255.

The mono audio formats supported are 8-bits PCM, 8-bits uLAW and 4-bits IMA-ADPCM. For ADPCM\_SAMPLES, each sample is 4 bits, so two samples are packed per byte, the first sample is in bits 0-3 and the second is in bits 4-7.

The current audio playback read pointer can be queried by reading the REG\_PLAYBACK\_READPTR. Using a large sample buffer, looping, and this read pointer, the host MPU/MCU can supply a continuous stream of audio.

For more details on the FT81x Audio Engine, please refer to pages 30-32 of the official FT81x Datasheet: <https://support.newhavendisplay.com/hc/en-us/articles/6963170802839-FT81x>



## Audio Filter and Amplifier Reference Circuit

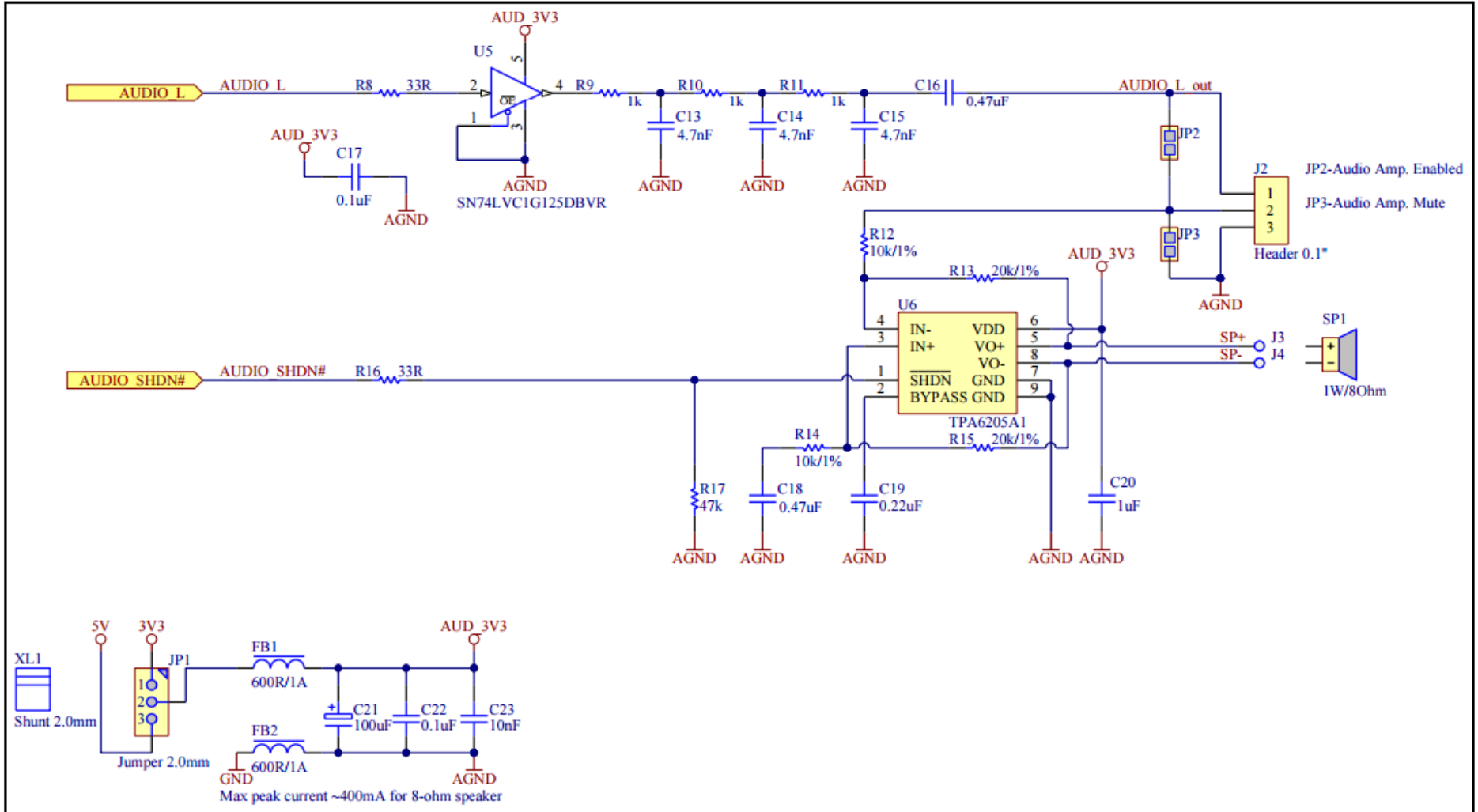

This is a reference schematic from FTDI, which can be used to successfully filter and amplify the audio signals coming from the NHD EVE2 TFT Module



## Additional Information/Resources

### FT81x Datasheet:

FTDI/Bridgetek FT81x Embedded Video Engine (EVE2)

<https://support.newhavendisplay.com/hc/en-us/articles/6963170802839-FT81x>

### Programmers Guide:

FT81x Series Programmers Guide

[http://www.ftdichip.com/Support/Documents/ProgramGuides/FT81X\\_Series\\_Programmer\\_Guide.pdf](http://www.ftdichip.com/Support/Documents/ProgramGuides/FT81X_Series_Programmer_Guide.pdf)

### NHD GitHub Page:

NHD EVE2 TFT Module Example Projects

<https://github.com/NewhavenDisplay/EVE2-TFT-Modules>

### EVE2 Software Examples:

FT81x Example Projects

[http://www.ftdichip.com/Support/SoftwareExamples/FT800\\_Projects.htm](http://www.ftdichip.com/Support/SoftwareExamples/FT800_Projects.htm)

### FTDI/Bridgetek Utilities:

Screen Designer

<http://www.ftdichip.com/Support/Utilities.htm#ESD3>

Image Converters

<http://www.ftdichip.com/Support/Utilities.htm#EVEImageConverters>

Audio Converter

<http://www.ftdichip.com/Support/Utilities.htm#EVEAudioConverter>

Font Converter

<http://www.ftdichip.com/Support/Utilities.htm#EVEFontConverter>

### FT80x to FT81x Migration Guide:

FT80x to FT81x Migration Guide

[http://www.ftdichip.com/Support/Documents/AppNotes/AN\\_390%20FT80x%20To%20FT81x%20Migration%20Guide.pdf](http://www.ftdichip.com/Support/Documents/AppNotes/AN_390%20FT80x%20To%20FT81x%20Migration%20Guide.pdf)



## Quality Information

Test Item	Content of Test	Test Condition	Note
High Temperature storage	Endurance test applying the high storage temperature for a long time.	+80°C, 240hrs	2
Low Temperature storage	Endurance test applying the low storage temperature for a long time.	-30°C, 240hrs	1,2
High Temperature Operation	Endurance test applying the electric stress (voltage & current) and the high thermal stress for a long time.	+70°C, 240hrs	2
Low Temperature Operation	Endurance test applying the electric stress (voltage & current) and the low thermal stress for a long time.	-20°C, 240hrs	1,2
High Temperature / Humidity Storage	Endurance test applying the electric stress (voltage & current) and the high thermal with high humidity stress for a long time.	+60°C, 90% RH, 240hrs	1,2
Thermal Shock resistance	Endurance test applying the electric stress (voltage & current) during a cycle of low and high thermal stress.	--30°C,30min -> 25°C,3min -> 80°C,30min = 1 cycle 20 cycles	
Vibration test	Endurance test applying vibration to simulate transportation and use.	10-55Hz, 5G Acceleration 60 sec in each of 3 directions (X, Y, Z) For 30 minutes	3
Static electricity test	Endurance test applying electric static discharge.	Air: ±8kV 150pF/330kΩ, 5 Times	
		Contact: ±4kV 150pF/330kΩ, 5 Times	

**Note 1:** No condensation to be observed.

**Note 2:** Conducted after 2 hours of storage at 25°C, 0%RH.

**Note 3:** Test performed on product itself, not inside a container.