

Buchseinsatz komplett (Kontakt Pin 5 vormontiert)  
female insert assembled (contact pin 5 pre-assembled)

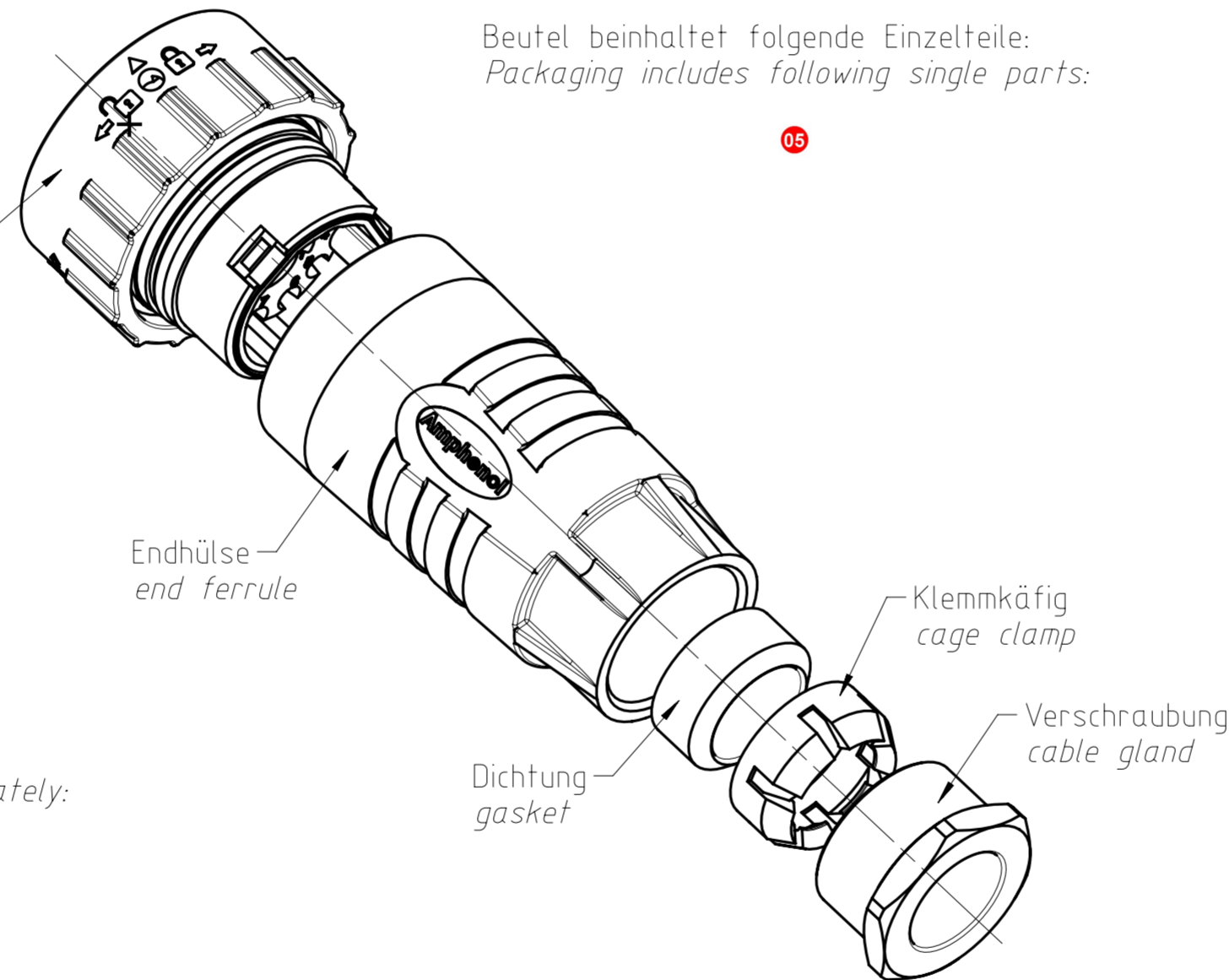

Beutel beinhaltet folgende Einzelteile:  
Packaging includes following single parts:

Kontakte bitte separat bestellen / Please order contacts separately:

Size 8 (2x benötigt / 2x needed):

- 6mm<sup>2</sup> - VN02 036 0026 6
- 10mm<sup>2</sup> - VN02 036 0027 6
- 16mm<sup>2</sup> - VN02 036 0028 6

Size 12 (2x benötigt / 2x needed):

- gestanzt / stamped (AWG 12-14): AT62-12-0166 (nickel plated) / AT62-12-0144 (gold plated)
- gedreht / turned (AWG 12-14): AT62-203-12141 (nickel plated) / AT62-210-1231 (gold plated)

Size 16 (4x benötigt / 4x needed):

- gestanzt / stamped (0,34-0,5mm<sup>2</sup>): AT62-16-0822 (nickel plated) / AT62-16-0844 (gold plated)
- gestanzt / stamped (AWG 18-20): AT62-16-0622 (nickel plated) / AT62-16-0644 (gold plated)
- gedreht / turned (AWG 16-20): AT62-201-16141 (nickel plated) / AT62-201-1631 (gold plated)

Weitere Kontakte auf Anfrage / other contacts on request

Alle technischen Daten wurden unter Laborbedingungen ermittelt und können im Praxisbetrieb abweichen.  
Es handelt sich bei den Angaben weder um Beschaffenheits- noch um Haltbarkeitsgarantien.  
All technical data have been measured in a laboratory environment and can be different during practical usage of the product.  
Any product information is for descriptive usage only and not legally binding. Particular information does not constitute or provide any legal guarantees ("Beschaffenheitsgarantie" or "Haltbarkeitsgarantie").

Weitergabe sowie Vervielfältigung dieser Unterlage, Verwertung und Mitteilung ihres Inhalts nicht gestattet, soweit nicht ausdrücklich zugestanden. Zuwiderhandlungen verpflichten zu Schadenersatz. Alle Rechte für den Fall der Patenterteilung oder Gebrauchsmuster-Eintragung vorbehalten.

Copying of this document and giving it to others and the use or communication of the contents thereof, are forbidden without express authority. Offenders are liable to the payment of damages. All rights are reserved in the event of the grant of a patent or the registration of the utility model or design.

|  |  |
|--|--|
| Polzahl<br>number of contacts  | 2+2+4+1  |
| Kontakte<br>contacts   | 2x Size 8<br>2x Size 12<br>4x Size 16<br>1x Size 16 überbrückt / bridged   |
| Bemessungsspannung (DIN EN 60664-1)<br>Rated voltage (DIN EN 60664-1)  | 24VDC  |
| Strombelastbarkeit bei +40°C<br>(alle Kontakte belastet)<br>Current carrying capacity at 40°C<br>(all contacts under load) | 2x45A (6mm <sup>2</sup> )<br>2x60A (10mm <sup>2</sup> ) <b>05</b><br>2x75A (16mm <sup>2</sup> ) <b>05</b><br><br>2x15A (2,5mm <sup>2</sup> )<br>4x5A (0,5mm <sup>2</sup> ) |
| Max. Strombelastbarkeit<br>der Kontakte bei +40°C<br>max. current carrying capacity<br>of contacts at +40°C                | 2x50A (6mm <sup>2</sup> )<br>2x70A (10mm <sup>2</sup> )<br>2x80A (16mm <sup>2</sup> ) <b>05</b><br>2x25A (2,5mm <sup>2</sup> )   |
| Verschmutzungsgrad<br>Pollution degree   | 3  |
| Temperaturbereich<br>Temperature range   | -40°C bis +125°C<br>-40°F up to +257°F   |
| Schutzgrad<br>protection class   | IP67 / IP6K9K (gesteckt)<br>IP67 / IP6K9K (mated)  |
| Mechanische Lebensdauer<br>Mechanical operations   | ≥100 Steckzyklen<br>≥100 mating cycles   |
| Werkstoff Dichtungen<br>material gaskets   | NBR, Silikon<br>NBR, silicone  |
| Werkstoff Gehäuse<br>material housing  | Polyamid schwarz, UL94V-0<br>polyamide black, UL94V-0  |
| Werkstoff Kontaktträger<br>material housing  | Polyamid schwarz, UL94V-0<br>polyamide black, UL94V-0  |
| Werkstoff Kontakte + Oberfläche<br>material contacts + surface   | Kupferlegierung, vernickelt<br>copper alloy, nickel plated   |
| Anschließbare Kabeldurchmesser<br>Possible cable diameter  | 14 - 18mm  |
| Verriegelung<br>locking  | Bajonett<br>Bayonet  |

Stecker nach ISO 11783-2  
connector acc. to ISO 11783-2

Version frei konfektionierbar mit Kabelverschraubung  
version free assembly with cable gland

Crimpausrüstung siehe Montageanleitung

- N 22 000 0024 (6mm<sup>2</sup>)
- N 22 000 0025 (10mm<sup>2</sup>)
- N 22 000 0026 (16mm<sup>2</sup>)

equipment for crimping according to assembly instruction

- N 22 000 0024 (6mm<sup>2</sup>)
- N 22 000 0025 (10mm<sup>2</sup>)
- N 22 000 0026 (16mm<sup>2</sup>)

|   |                       |                                     |                            |   |
|---|-----------------------|-------------------------------------|----------------------------|---|
| Gewicht (errechnet) / Calc. WT.: 0,111 kg | Zul. Abw./Tolerances: | Maßstab / Scale: 1:1                | A2                         | ☐ |
| Prüfmaß / Testdimension                   | ISO 2768-c            | CUSTOMER DRAWING                    |                            |   |
| Teilindex / Partindexnumber:              |                       |                                     |                            |   |
| Bagatelle change:                         |                       |                                     |                            |   |
|   | Gez. 26.10.2016       | Kabeldose<br>female cable connector |                            |   |
|   | Drawn RSCHAEDEL       |                                     |                            |   |
|   | Status Released       | M AHDP06-24-91S-BS1                 |                            |   |
|   | Gepr. 18.07.2019      |                                     |                            |   |
|   | Checked MGRIMM        | Amphenol Tuchel Industrial GmbH     |                            |   |
| 05 201900126 24.07.2019 SWAHL             |                       |                                     |                            |   |
| 04 201700501 26.02.2018 RSCHA             |                       | Blatt / Sheet 1                     |                            |   |
| 03 201500766 13.04.2017 NPFEI             |                       |                                     |                            |   |
| 02 201500766 15.02.2017 RSCHA             |                       | 1 Bl.                               |                            |   |
| 01 201500766 02.02.2017 RSCHA             |                       |                                     |                            |   |
| Index / Änderung / Description            | Datum / Date          | Name                                | Ers. f. / Replacement for: |   |

FAI2019-000706

# AT Series™ - Contact Size 16 Options

| Machined Contacts, Sockets & Pins |  |      |       |          |
|-----------------------------------|--|------|-------|----------|
| Part Number                       | Description                            | Size | AWG   | Type     |
| AT60-215-1631                     | Male Contact - Pin, Gold-plated        | 16   | 14    | Machined |
| AT62-209-1631                     | Female Contact - Socket, Gold-plated   | 16   | 14    | Machined |
| AT60-215-16141                    | Male Contact - Pin, Nickel-plated      | 16   | 14    | Machined |
| AT62-209-16141                    | Female Contact - Socket, Nickel-plated | 16   | 14    | Machined |
| AT60-202-1631                     | Male Contact - Pin, Gold-plated        | 16   | 16-20 | Machined |
| AT62-201-1631                     | Female Contact - Socket, Gold-plated   | 16   | 16-20 | Machined |
| AT60-202-16141                    | Male Contact - Pin, Nickel-plated      | 16   | 16-20 | Machined |
| AT62-201-16141                    | Female Contact - Socket, Nickel-plated | 16   | 16-20 | Machined |
| AT60-202-1631-22                  | Male Contact - Pin, Gold-plated        | 16   | 22-24 | Machined |
| AT62-201-1631-22                  | Female Contact - Socket, Gold-plated   | 16   | 22-24 | Machined |
| AT60-202-16141-22                 | Male Contact - Pin, Nickel-plated      | 16   | 22-24 | Machined |
| AT62-201-16141-22                 | Female Contact - Socket, Nickel-plated | 16   | 22-24 | Machined |

| Tooling - Machined Contacts   |             |   |
|---|-------------|---|
| Part  | Part Number | Description   |
|  | CA-5D12     | Universal Hand Crimp Tool, Size 12/16/20 (Machined contacts only) |
|  | CA-5E12     | Pneumatic Crimp Tool, Size 12/16/20 (Machined contacts only)      |

| Contact Removal Tools   |               |   |
|---|---------------|---|
| Part  | Part Number   | Description   |
|  | ATRT-100      | Used for removal of contacts for A Series™ products |
|  | AT11-310-1605 | Contact Removal Tool, Plastic, Size 16              |
|  | A114017       | Sealing Plug, Size 16, White                        |

| Stamped & Formed Contacts, Sockets & Pins |  |      |       |                  |
|---|--|------|-------|------------------|
| Part Number                               | Description                            | Size | AWG   | Type             |
| AT60-14-0144                              | Male Contact - Pin, Gold-plated        | 16   | 14-16 | Stamped & Formed |
| AT62-14-0144                              | Female Contact - Socket, Gold-plated   | 16   | 14-16 | Stamped & Formed |
| AT60-14-0122                              | Male Contact - Pin, Nickel-plated      | 16   | 14-16 | Stamped & Formed |
| AT62-14-0122                              | Female Contact - Socket, Nickel-plated | 16   | 14-16 | Stamped & Formed |
| AT60-16-0144                              | Male Contact - Pin, Gold-plated        | 16   | 16-18 | Stamped & Formed |
| AT62-16-0144                              | Female Contact - Socket, Gold-plated   | 16   | 16-18 | Stamped & Formed |
| AT60-16-0122                              | Male Contact - Pin, Nickel-plated      | 16   | 16-18 | Stamped & Formed |
| AT62-16-0122                              | Female Contact - Socket, Nickel-plated | 16   | 16-18 | Stamped & Formed |
| AT60-16-0644                              | Male Contact - Pin, Gold-plated        | 16   | 18-20 | Stamped & Formed |
| AT62-16-0644                              | Female Contact - Socket, Gold-plated   | 16   | 18-20 | Stamped & Formed |
| AT60-16-0622                              | Male Contact - Pin, Nickel-plated      | 16   | 18-20 | Stamped & Formed |
| AT62-16-0622                              | Female Contact - Socket, Nickel-plated | 16   | 18-20 | Stamped & Formed |
| AT60-16-0844                              | Male Contact - Pin, Gold-plated        | 16   | 20-22 | Stamped & Formed |
| AT62-16-0844                              | Female Contact - Socket, Gold-plated   | 16   | 20-22 | Stamped & Formed |
| AT60-16-0822                              | Male Contact - Pin, Nickel-plated      | 16   | 20-22 | Stamped & Formed |
| AT62-16-0822                              | Female Contact - Socket, Nickel-plated | 16   | 20-22 | Stamped & Formed |

| Tooling - Stamped & Formed Contacts   |             |   |
|---|-------------|---|
| Part  | Part Number | Description   |
|   | MFX-3950    | Crimp Die - Size 16, 18-20AWG (S&F contacts only)       |
|   | MFX-3953    | Crimp Die - Size 16, 16-18AWG (S&F contacts only)       |
|   | MFX-3975    | Crimp Die - Size 16, 14-16AWG (S&F contacts only)       |
|   | MFX-3990    | Crimp Die - Size 16, 20-22AWG (S&F contacts only)       |
|  | ATT-16-00   | Hand Crimp Tool - Size 16, 14-16AWG (S&F contacts only) |
|   | ATT-16-01   | Hand Crimp Tool - Size 16, 18-20AWG (S&F contacts only) |
|   | ATT-1612-03 | Hand Crimp Tool - Size 16, 20-22AWG (S&F contacts only) |

**Amphenol Sine Systems**  
 44724 Morley Drive  
 Clinton Township, MI 48036 USA  
[www.amphenol-sine.com](http://www.amphenol-sine.com)  
 09/2021

# MagnaMate™ ATHP - DuraMate™ AHDP - DuraMate™ AHDM Series - Contact Size 12 Options

| Machined Contacts, Sockets & Pins |  |      |       |          |
|-----------------------------------|--|------|-------|----------|
| Part Number                       | Description                            | Size | AWG   | Type     |
| AT60-204-12141-10                 | Male Contact - Pin, Nickel-plated      | 12   | 10-12 | Machined |
| AT62-203-12141-10                 | Female Contact - Socket, Nickel-plated | 12   | 10-12 | Machined |
| AT60-220-1231                     | Male Contact - Pin, Gold-plated        | 12   | 12-14 | Machined |
| AT62-210-1231                     | Female Contact - Socket, Gold-plated   | 12   | 12-14 | Machined |
| AT60-204-12141                    | Male Contact - Pin, Nickel-plated      | 12   | 12-14 | Machined |
| AT62-203-12141                    | Female Contact - Socket, Nickel-plated | 12   | 12-14 | Machined |

| DiagnosticGrade™ Machined Contacts, Sockets & Pins   |  |      |     |          |
|--|--|------|-----|----------|
| • Smaller AWG for Diagnostic Applications • Gold-plated • Increased Mating Cycles • Cost-effective |  |      |     |          |
| Part Number  | Description  | Size | AWG | Type     |
| 65-54749   | Male Contact - DiagnosticGrade™, Pin, Gold-plated      | 12   | 20  | Machined |
| AT62-210-1231-1820   | Female Contact - DiagnosticGrade™, Socket, Gold-plated | 12   | 20  | Machined |

| Tooling - Machined Contacts   |             |   |
|---|-------------|---|
| Part  | Part Number | Description   |
|  | CA-5D12     | Universal Hand Crimp Tool, Size 12/16/20 (Machined contacts only) |
|  | CA-5E12     | Pneumatic Crimp Tool, Size 12/16/20 (Machined contacts only)      |

| Contact Removal Tools   |               |  |
|---|---------------|--|
| Part  | Part Number   | Description                            |
|  | AT11-337-1205 | Contact Removal Tool, Plastic, Size 12 |
|  | A114017       | Sealing Plug, Size 12, White           |

| Stamped & Formed Contacts, Sockets & Pins |  |      |       |                  |
|---|--|------|-------|------------------|
| Part Number                               | Description                            | Size | AWG   | Type             |
| AT60-12-0244                              | Male Contact - Pin, Gold-plated        | 12   | 10-12 | Stamped & Formed |
| AT62-12-0244                              | Female Contact - Socket, Gold-plated   | 12   | 10-12 | Stamped & Formed |
| AT60-12-0222                              | Male Contact - Pin, Nickel-plated      | 12   | 10-12 | Stamped & Formed |
| AT62-12-0222                              | Female Contact - Socket, Nickel-plated | 12   | 10-12 | Stamped & Formed |
| AT60-12-0144                              | Male Contact - Pin, Gold-plated        | 12   | 12-14 | Stamped & Formed |
| AT62-12-0144                              | Female Contact - Socket, Gold-plated   | 12   | 12-14 | Stamped & Formed |
| AT60-12-0166                              | Male Contact - Pin, Nickel-plated      | 12   | 12-14 | Stamped & Formed |
| AT62-12-0166                              | Female Contact - Socket, Nickel-plated | 12   | 12-14 | Stamped & Formed |

| Tooling - Stamped & Formed Contacts   |             |   |
|---|-------------|---|
| Part  | Part Number | Description   |
|  | MFX-3973    | Crimp Die - Size 12 (S&F contacts only)                       |
|   | MFX-3985    | Crimp Die - Size 12 (S&F contacts only) 10-12AWG -02XX Series |
|  | ATT-12-00   | Hand Crimp Tool - Size 12, 12AWG (S&F contacts only)          |
|   | ATT-12-01   | Hand Crimp Tool - Size 12, 10AWG (S&F contacts only)          |

**Amphenol Sine Systems**  
 44724 Morley Drive  
 Clinton Township, MI 48036 USA  
[www.amphenol-sine.com](http://www.amphenol-sine.com)  
 01/2022

Copying of this document and giving it to others and the use or communication of the contents thereof, are forbidden without express authority. Offenders are liable to the payment of damages. All rights are reserved in the event of the grant of a patent or the registration of the utility model or design.

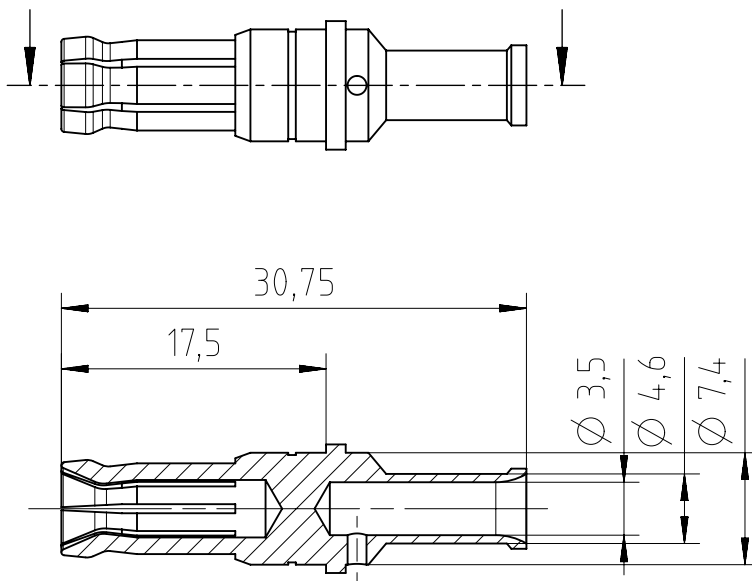

Material: Kupferlegierung  
*material: copper alloy*  
 Oberfläche: vernickelt  
*surface coating: nickel plated*  
 Für Kontaktstift  $\varnothing$  3,6mm  
*for male contact  $\varnothing$  3,6mm*

Anschlussquerschnitt: 6mm<sup>2</sup>  
*cross section: 6mm<sup>2</sup>*

100 Stück in einem Beutel verpackt  
*100 pcs packed in one poly bag*

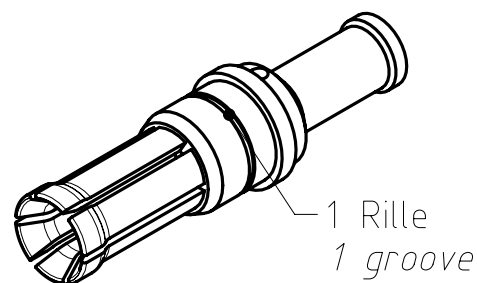

Alle technischen Daten wurden unter Laborbedingungen ermittelt und können im Praxisbetrieb abweichen.  
 Es handelt sich bei den Angaben weder um Beschaffenheits- noch um Haltbarkeitsgarantien.  
*All technical data have been measured in a laboratory environment and can be different during practical usage of the product. Any product information is for descriptive usage only and not legally binding, particularly the information does not constitute or provide any legal guarantees ("Beschaffenheitsgarantie" or "Haltbarkeitsgarantie").*

Weitergabe sowie Vervielfältigung dieser Unterlage, Verwertung und Mitteilung ihres Inhalts nicht gestattet, soweit nicht ausdrücklich zugestanden. Zuwiderhandlungen verpflichten zu Schadensersatz. Alle Rechte für den Fall der Patenterteilung oder Gebrauchsmuster-Eintragung vorbehalten.

|                                 |                        |                        |              |  |  |   |  |  |  |
|---------------------------------|------------------------|------------------------|--------------|--|--|---|--|--|--|
| Gewicht (errechnet) / Calc WT : |                        | Zul. Abw./Tolerances : |              | Maßstab / Scale : 2:1                      |  | A4                                      |  |  |  |
| Prüfmaß / Testdimension         |                        | ISO 2768-mH            |              |  |  | CUSTOMER DRAWING                        |  |  |  |
| Teileindex / Partindexnumber:   |                        |                        |              |  |  |   |  |  |  |
| Bagatelle change:               |                        |                        |              |  |  | Buchsenkontakt<br><i>female contact</i> |  |  |  |
|                                 |                        | Gez.                   | 30.03.2017   |  |  |   |  |  |  |
|                                 |                        | Drawn                  | AZN_NPFEIFFE |  |  |   |  |  |  |
|                                 |                        | Status                 | Released     |  |  |   |  |  |  |
|                                 |                        | Gepr.                  | 01.04.2019   |  |  |   |  |  |  |
|                                 |                        | Checked                | MGRIMM       | M   VN 02 036 0026 6                       |  | Blatt / Sheet<br>1<br>1 Bl.             |  |  |  |
| 04                              | 201900099              | 01.04.2019             | MTOLK        |  |  |   |  |  |  |
| 03                              | 201800125              | 01.03.2018             | NPFEL        |  |  |   |  |  |  |
| 02                              | 201800066              | 25.01.2018             | NPFEL        |  |  |   |  |  |  |
| 01                              | 201500766              | 31.03.2017             | NPFEL        | <b>Amphenol Tuchel<br/>Industrial GmbH</b> |  | Ers. f. / Replacement for :             |  |  |  |
| Index                           | Änderung / Description | Datum / Date           | Name         |  |  |   |  |  |  |

Copying of this document and giving it to others and the use or communication of the contents thereof, are forbidden without express authority. Offenders are liable to the payment of damages. All rights are reserved in the event of the grant of a patent or the registration of the utility model or design.

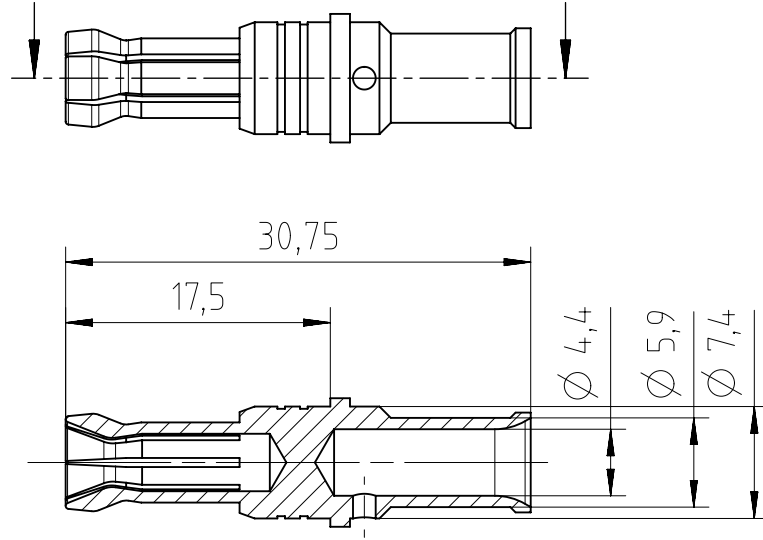

Material: Kupferlegierung  
*material: copper alloy*  
 Oberfläche: vernickelt  
*surface coating: nickel plated*  
 Für Kontaktstift  $\varnothing$  3,6mm  
*for male contact  $\varnothing$  3,6mm*

Anschlussquerschnitt: 10mm<sup>2</sup>  
*cross section: 10mm<sup>2</sup>*

100 Stück in einem Beutel verpackt  
*100 pcs packed in one poly bag*

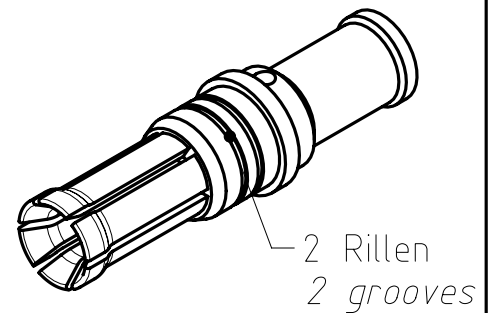

Alle technischen Daten wurden unter Laborbedingungen ermittelt und können im Praxisbetrieb abweichen.  
 Es handelt sich bei den Angaben weder um Beschaffenheits- noch um Haltbarkeitsgarantien.  
*All technical data have been measured in a laboratory environment and can be different during practical usage of the product. Any product information is for descriptive usage only and not legally binding; particularly the information does not constitute or provide any legal guarantees ("Beschaffenheitsgarantie" or "Haltbarkeitsgarantie").*

Weitergabe sowie Vervielfältigung dieser Unterlage, Verwertung und Mitteilung ihres Inhalts nicht gestattet, soweit nicht ausdrücklich zugestanden. Zuwiderhandlungen verpflichten zu Schadensersatz. Alle Rechte für den Fall der Patenterteilung oder Gebrauchsmuster-Eintragung vorbehalten.

|                                 |                        |                        |              |  |  |   |  |  |  |                    |  |
|---------------------------------|------------------------|------------------------|--------------|--|--|---|--|--|--|--------------------|--|
| Gewicht (errechnet) / Calc WT : |                        | Zul. Abw./Tolerances : |              | Maßstab / Scale : 2:1                      |  | A4                                      |  |  |  |                    |  |
| Prüfmaß / Testdimension         |                        | ISO 2768-mH            |              |  |  | CUSTOMER DRAWING                        |  |  |  |                    |  |
| Teileindex / Partindexnumber:   |                        |                        |              |  |  |   |  |  |  |                    |  |
| Bagatelle change:               |                        |                        |              |  |  | Buchsenkontakt<br><i>female contact</i> |  |  |  |                    |  |
|                                 |                        | Gez.                   | 30.03.2017   | M   VN 02 036 0027 6                       |  |   |  |  |  | Blatt / Sheet<br>1 |  |
|                                 |                        | Drawn                  | AZN_NPFEIFFE |  |  |   |  |  |  |                    |  |
|                                 |                        | Status                 | Released     |  |  |   |  |  |  |                    |  |
|                                 |                        | Gepr.                  | 01.04.2019   |  |  |   |  |  |  |                    |  |
|                                 |                        | Checked                | MGRIMM       |  |  |   |  |  |  |                    |  |
| 04                              | 201900099              | 01.04.2019             | MTOLK        | <b>Amphenol Tuchel<br/>Industrial GmbH</b> |  | 1 Bl.                                   |  |  |  |                    |  |
| 03                              | 201800125              | 01.03.2018             | NPFEL        |  |  |   |  |  |  |                    |  |
| 02                              | 201800066              | 25.01.2018             | NPFEL        |  |  |   |  |  |  |                    |  |
| 01                              | 201500766              | 31.03.2017             | NPFEL        |  |  |   |  |  |  |                    |  |
| Index                           | Anderung / Description | Datum / Date           | Name         | Ers. f. / Replacement for :                |  |   |  |  |  |                    |  |

Copying of this document and giving it to others and the use or communication of the contents thereof, are forbidden without express authority. Offenders are liable to the payment of damages. All rights are reserved in the event of the grant of a patent or the registration of the utility model or design.

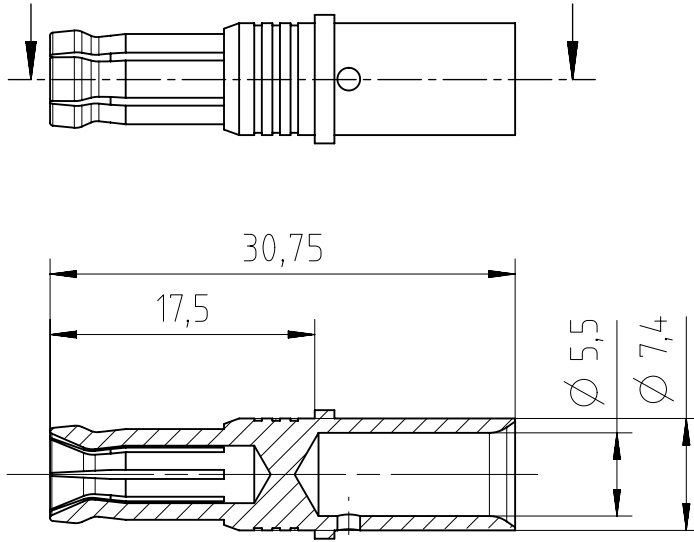

Material: Kupferlegierung  
*material: copper alloy*  
 Oberfläche: vernickelt  
*surface coating: nickel plated*  
 Für Kontaktstift  $\varnothing$  3,6mm  
*for male contact  $\varnothing$  3,6mm*

Anschlussquerschnitt: 16mm<sup>2</sup>  
*cross section: 16mm<sup>2</sup>*

100 Stück in einem Beutel verpackt  
*100 pcs packed in one poly bag*

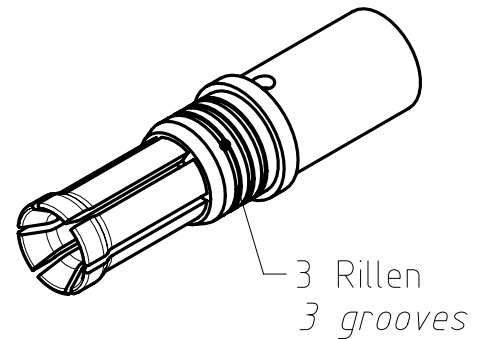

Alle technischen Daten wurden unter Laborbedingungen ermittelt und können im Praxisbetrieb abweichen.  
 Es handelt sich bei den Angaben weder um Beschaffenheits- noch um Haltbarkeitsgarantien.  
*All technical data have been measured in a laboratory environment and can be different during practical usage of the product. Any product information is for descriptive usage only and not legally binding; particularly the information does not constitute or provide any legal guarantees ("Beschaffenheitsgarantie" or "Haltbarkeitsgarantie").*

Weitergabe sowie Vervielfältigung dieser Unterlage, Verwertung und Mitteilung ihres Inhalts nicht gestattet, soweit nicht ausdrücklich zugestanden. Zuwiderhandlungen verpflichten zu Schadensersatz. Alle Rechte für den Fall der Patenterteilung oder Gebrauchsmuster-Eintragung vorbehalten.

|                                 |                        |                        |              |  |  |   |  |                             |  |
|---------------------------------|------------------------|------------------------|--------------|--|--|---|--|-----------------------------|--|
| Gewicht (errechnet) / Calc WT : |                        | Zul. Abw./Tolerances : |              | Maßstab / Scale : 2:1                      |  | A4                                      |  |                             |  |
| Prüfmaß / Testdimension         |                        | ISO 2768-mH            |              |  |  | CUSTOMER DRAWING                        |  |                             |  |
| Teileindex / Partindexnumber:   |                        |                        |              |  |  |   |  |                             |  |
| Bagatelle change:               |                        |                        |              |  |  | Buchsenkontakt<br><i>female contact</i> |  |                             |  |
|                                 |                        | Gez.                   | 30.03.2017   |  |  |   |  |                             |  |
|                                 |                        | Drawn                  | AZN_NPFEIFFE |  |  |   |  |                             |  |
|                                 |                        | Status                 | Released     |  |  |   |  |                             |  |
|                                 |                        | Gepr.                  | 01.04.2019   |  |  |   |  |                             |  |
|                                 |                        | Checked                | MGRIMM       |  |  |   |  |                             |  |
| 04                              | 201900099              | 01.04.2019             | MTOLK        | <b>Amphenol Tuchel<br/>Industrial GmbH</b> |  | M VN 02 036 0028 6                      |  | Blatt / Sheet<br>1<br>1 Bl. |  |
| 03                              | 201800125              | 01.03.2018             | NPFEI        |  |  |   |  |                             |  |
| 02                              | 201800066              | 25.01.2018             | NPFEI        |  |  |   |  |                             |  |
| 01                              | 201500766              | 31.03.2017             | NPFEI        |  |  |   |  |                             |  |
| Index                           | Änderung / Description | Datum / Date           | Name         | Ers. f. / Replacement for :                |  |   |  |                             |  |