

R88D-KN□□□-ECT, R88D-KN□□□-ML2, R88D-KT□

Accurax G5 rotary drive

Accurate motion control in a compact size servo drive family. EtherCAT and safety built-in.

- EtherCAT, ML-II and Analog/pulse servo drive models
- Safety conforming ISO13849-1 PL-d
- High-response frequency of 2 kHz
- High resolution provided by 20 bits encoder
- Drive Programming: embedded indexer functionality in the Analogue/pulse models
- External encoder input for full closed loop
- Real time auto-tuning
- Advanced tuning algorithms (Anti-vibration function, torque feedforward, disturbance observer)



Ratings



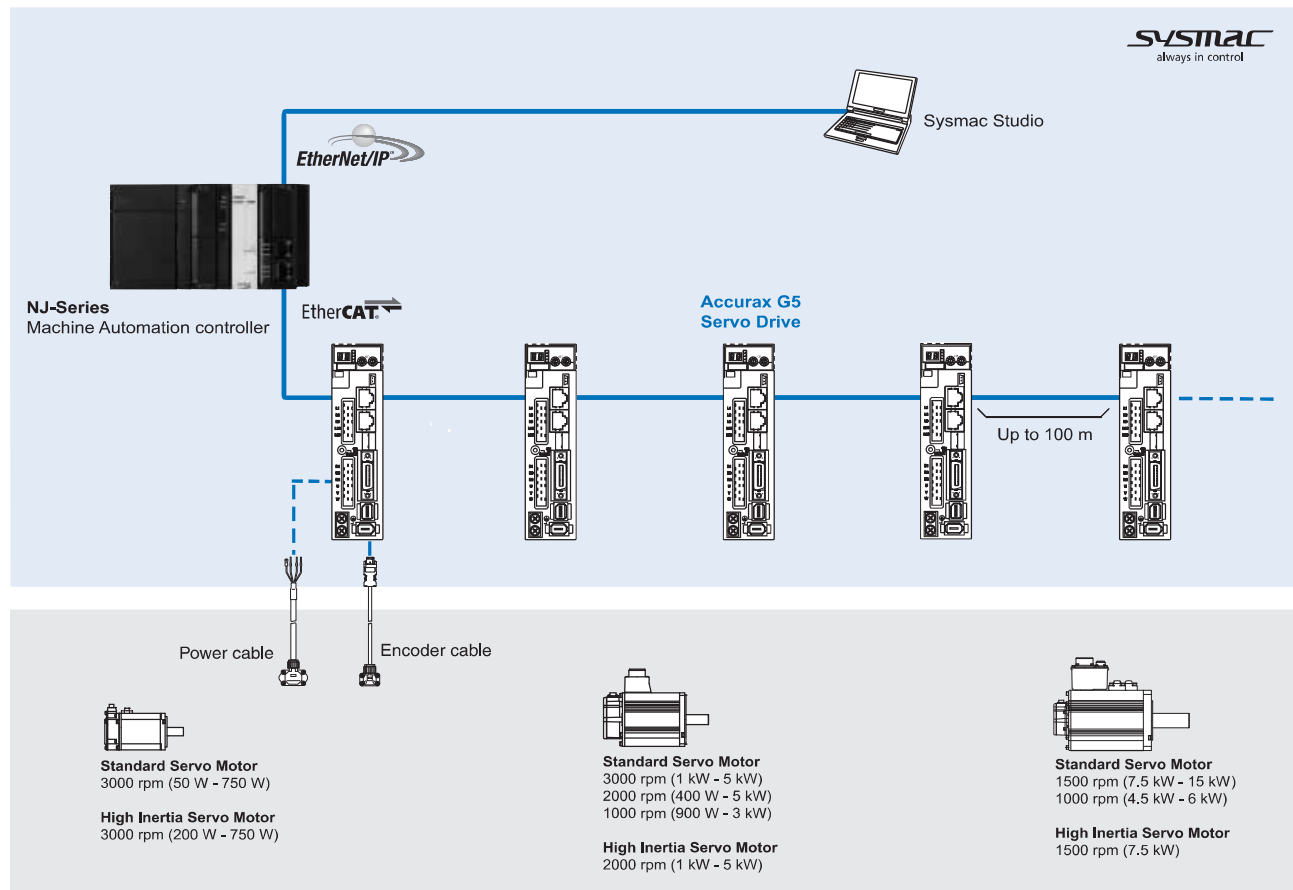

- 230 VAC single-phase 100 W to 1.5 kW (8.59 Nm)
- 400 VAC three-phase 600 W to 15 kW (95.5 Nm)

System configuration





Servo motor supported

Standard servo motors

Accurax G5 rotary servo motor						Accurax G5 servo drive models					
	Voltage	Speed	Rated torque	Capacity	Model	EtherCAT	Analog/pulse	MECHATROLINK-II			
	230 V	3000 min ⁻¹	0.16 Nm	50 W	R88M-K05030(H/T)-□	R88D-KN01H-ECT	R88D-KT01H	R88D-KN01H-ML2			
			0.32 Nm	100 W	R88M-K10030(H/T)-□	R88D-KN01H-ECT	R88D-KT01H	R88D-KN01H-ML2			
			0.64 Nm	200 W	R88M-K20030(H/T)-□	R88D-KN02H-ECT	R88D-KT02H	R88D-KN02H-ML2			
			1.3 Nm	400 W	R88M-K40030(H/T)-□	R88D-KN04H-ECT	R88D-KT04H	R88D-KN04H-ML2			
			2.4 Nm	750 W	R88M-K75030(H/T)-□	R88D-KN08H-ECT	R88D-KT08H	R88D-KN08H-ML2			
			3.18 Nm	1000 W	R88M-K1K030(H/T)-□	R88D-KN15H-ECT	R88D-KT15H	R88D-KN15H-ML2			
			4.77 Nm	1500 W	R88M-K1K530(H/T)-□	R88D-KN15H-ECT	R88D-KT15H	R88D-KN15H-ML2			
				400 V	3000 min ⁻¹	2.39 Nm	750 W	R88M-K75030(F/C)-□	R88D-KN10F-ECT	R88D-KT10F	R88D-KN10F-ML2
						3.18 Nm	1000 W	R88M-K1K030(F/C)-□	R88D-KN15F-ECT	R88D-KT15F	R88D-KN15F-ML2
						4.77 Nm	1500 W	R88M-K1K530(F/C)-□	R88D-KN15F-ECT	R88D-KT15F	R88D-KN15F-ML2
						6.37 Nm	2000 W	R88M-K2K030(F/C)-□	R88D-KN20F-ECT	R88D-KT20F	R88D-KN20F-ML2
						9.55 Nm	3000 W	R88M-K3K030(F/C)-□	R88D-KN30F-ECT	R88D-KT30F	R88D-KN30F-ML2
						12.7 Nm	4000 W	R88M-K4K030(F/C)-□	R88D-KN50F-ECT	R88D-KT50F	R88D-KN50F-ML2
						15.9 Nm	5000 W	R88M-K5K030(F/C)-□	R88D-KN50F-ECT	R88D-KT50F	R88D-KN50F-ML2
							230 V	2000 min ⁻¹	4.77 Nm	1000 W	R88M-K1K020(H/T)-□
7.16 Nm	1500 W	R88M-K1K520(H/T)-□							R88D-KN15H-ECT	R88D-KT15H	R88D-KN15H-ML2
1.91 Nm	400 W	R88M-K40020(F/C)-□	R88D-KN06F-ECT	R88D-KT06F	R88D-KN06F-ML2						
2.86 Nm	600 W	R88M-K60020(F/C)-□	R88D-KN06F-ECT	R88D-KT06F	R88D-KN06F-ML2						
4.77 Nm	1000 W	R88M-K1K020(F/C)-□	R88D-KN10F-ECT	R88D-KT10F	R88D-KN10F-ML2						
7.16 Nm	1500 W	R88M-K1K520(F/C)-□	R88D-KN15F-ECT	R88D-KT15F	R88D-KN15F-ML2						
	400 V	2000 min ⁻¹	9.55 Nm	2000 W	R88M-K2K020(F/C)-□	R88D-KN20F-ECT	R88D-KT20F	R88D-KN20F-ML2			
			14.3 Nm	3000 W	R88M-K3K020(F/C)-□	R88D-KN30F-ECT	R88D-KT30F	R88D-KN30F-ML2			
			19.1 Nm	4000 W	R88M-K4K020(F/C)-□	R88D-KN50F-ECT	R88D-KT50F	R88D-KN50F-ML2			
			23.9 Nm	5000 W	R88M-K5K020(F/C)-□	R88D-KN50F-ECT	R88D-KT50F	R88D-KN50F-ML2			
			1500 min ⁻¹	47.8 Nm	7500 W	R88M-K7K515C-□	R88D-KN75F-ECT	R88D-KT75F	-		
				70.0 Nm	11000 W	R88M-K11K015C-□	R88D-KN150F-ECT	R88D-KT150F	-		
		95.5 Nm		15000 W	R88M-K15K015C-□	R88D-KN150F-ECT	R88D-KT150F	-			
				230 V	1000 min ⁻¹	8.59 Nm	900 W	R88M-K90010(H/T)-□	R88D-KN15H-ECT	R88D-KT15H	R88D-KN15H-ML2
						8.59 Nm	900 W	R88M-K90010(F/C)-□	R88D-KN15F-ECT	R88D-KT15F	R88D-KN15F-ML2
						19.1 Nm	2000 W	R88M-K2K010(F/C)-□	R88D-KN30F-ECT	R88D-KT30F	R88D-KN30F-ML2
		400 V	1000 min ⁻¹	28.7 Nm	3000 W	R88M-K3K010(F/C)-□	R88D-KN50F-ECT	R88D-KT50F	R88D-KN50F-ML2		
				43.0 Nm	4500 W	R88M-K4K510C-□	R88D-KN50F-ECT	R88D-KT50F	R88D-KN50F-ML2		
57.3 Nm	6000 W			R88M-K6K010C-□	R88D-KN75F-ECT	R88D-KT75F	-				

High inertia servo motors

Accurax G5 rotary servo motor						Accurax G5 servo drive models		
	Voltage	Speed	Rated torque	Capacity	Model	EtherCAT	Analog/pulse	MECHATROLINK-II
	230 V	3000 min ⁻¹	0.64 Nm	200 W	R88M-KH20030(H/T)-□	R88D-KN02H-ECT	R88D-KT02H	R88D-KN02H-ML2
			1.3 Nm	400 W	R88M-KH40030(H/T)-□	R88D-KN04H-ECT	R88D-KT04H	R88D-KN04H-ML2
			2.4 Nm	750 W	R88M-KH75030(H/T)-□	R88D-KN08H-ECT	R88D-KT08H	R88D-KN08H-ML2
	400 V	2000 min ⁻¹	4.77 Nm	1000 W	R88M-KH1K020(F/C)-□	R88D-KN10F-ECT	R88D-KT10F	R88D-KN10F-ML2
			7.16 Nm	1500 W	R88M-KH1K520(F/C)-□	R88D-KN15F-ECT	R88D-KT15F	R88D-KN15F-ML2
			9.55 Nm	2000 W	R88M-KH2K020(F/C)-□	R88D-KN20F-ECT	R88D-KT20F	R88D-KN20F-ML2
			14.3 Nm	3000 W	R88M-KH3K020(F/C)-□	R88D-KN30F-ECT	R88D-KT30F	R88D-KN30F-ML2
			19.1 Nm	4000 W	R88M-KH4K020(F/C)-□	R88D-KN50F-ECT	R88D-KT50F	R88D-KN50F-ML2
			23.9 Nm	5000 W	R88M-KH5K020(F/C)-□	R88D-KN50F-ECT	R88D-KT50F	R88D-KN50F-ML2
				400 V	1500 min ⁻¹	47.8 Nm	7500 W	R88M-KH7K515C-□

Type designation

Servo drive

R88D-KN01H-ECT

Accurax G5 Series servo drive

Drive Type

T: Analog/pulse type

N: Network type

Model

Blank: Analog/pulse type

ECT: EtherCAT comms

ML2: MECHATROLINK-II comms

Capacity and Voltage

Voltage	Code	Output
230 V	01H	100 W
	02H	200 W
	04H	400 W
	08H	750 W
	10H	1 kW
	15H	1.5 kW
400 V	06F	600 W
	10F	1.0 kW
	15F	1.5 kW
	20F	2.0 kW
	30F	3.0 kW
	50F	5.0 kW
	75F	7.5 kW
	150F	15.0 kW

Servo drive specifications

Single-phase, 230 V

Servo drive type		R88D-K□	01H□	02H□	04H□	08H□	10H□	15H□
Applicable servo motor	R88M-K□	05030(H/T)-□	20030(H/T)-□	40030(H/T)-□	75030(H/T)-□	1K020(H/T)-□	1K030(H/T)-□	
		10030(H/T)-□	–	–	–	–	1K530(H/T)-□	
		–	–	–	–	–	1K520(H/T)-□	
		–	–	–	–	–	90010(H/T)-□	
Max. applicable motor capacity W		100	200	400	750	1000	1500	
Continuous output current Arms		1.2	1.6	2.6	4.1	5.9	9.4	
Input power	Main circuit	Single-phase/3-phase, 200 to 240 VAC +10 to –15% (50/60 Hz)						
	Control circuit	Single-phase, 200 to 240 VAC +10 to –15% (50/60 Hz)						
Control method		IGBT-driven PWM method, sinusoidal drive						
Feedback		Serial encoder (incremental/absolute value)						
Conditions	Usage/storage temperature		0 to +55°C/–20 to 65°C					
	Usage/storage humidity		90% RH or less (non-condensing)					
	Altitude		1000m or less above sea level					
	Vibration/shock resistance (max.)		5.88 m/s ² 10 to 60 Hz (Continuous operation at resonance point is not allowed) / 19.6 m/s ²					
Configuration		Base mounted						
Approx. weight kg		0.8	1.1	1.6	1.8			

Three-phase, 400 V

Servo drive type		R88D-K□	06F□	10F□	15F□	20F□	30F□	50F□	75F□	150F□
Applicable servo motor	R88M-K□	40020(F/C)-□	75030(F/C)-□	1K030(F/C)-□	2K030(F/C)-□	3K030(F/C)-□	4K030(F/C)-□	6K010C-□	11K015C-□	
		60020(F/C)-□	1K020(F/C)-□	1K530(F/C)-□	2K020(F/C)-□	3K020(F/C)-□	5K030(F/C)-□	7K515C-□	15K015C-□	
		–	–	1K520(F/C)-□	–	2K010(F/C)-□	4K020(F/C)-□	–	–	
		–	–	90010(F/C)-□	–	–	5K020(F/C)-□	–	–	
		–	–	–	–	–	4K510C-□	–	–	
		–	–	–	–	–	3K010(F/C)-□	–	–	
Max. applicable motor capacity kW		0.6	1.0	1.5	2.0	3.0	5.0	7.5	15.0	
Continuous output current Arms		1.5	2.9	4.7	6.7	9.4	16.5	22.0	33.4	
Input power	Main circuit	3-phase, 380 to 480 VAC +10 to –15% (50/60Hz)								
	Control circuit	24 VDC ±15%								
Control method		IGBT-driven PWM method, sinusoidal drive								
Feedback		Serial encoder						Absolute encoder		
Conditions	Usage/storage temperature		0 to 55°C/–20 to 65°C							
	Usage/storage humidity		90% RH or less (non-condensing)							
	Altitude		1000 m or less above sea level							
	Vibration/shock resistance		5.88 m/s ² 10 to 60 Hz (Continuous operation at resonance point is not allowed)/19.6 m/s ²							
Configuration		Base mounted								
Approx. weight kg		1.9	2.7	4.7	13.5	21.0				

General specifications (for EtherCAT servo drives)

Performance		Frequency characteristics	2 kHz	
EtherCAT interface	Command input		EtherCAT commands (for sequence, motion, data setting/reference, monitor, adjustment, and other commands).	
	Drive Profile ^{*1}		CSP, CSV, CST, Homing and Position Profile modes (CiA402 Drive Profile) Homing mode Position profile mode Dual touch probe function (Latch function) Torque limit function	
I/O signal	Sequence input signal		Multi-function input × 8 by parameter setting (forward/reverse drive prohibition, emergency stop, external latch, origin proximity, forward/reverse torque limit, general purpose monitor input).	
	Sequence output signal		1 × servo drive error output 2 × multi-function outputs by parameters setting (servo ready, brake release, torque limit detection, zero speed detection, warning output, position completion, error clear attributed, programmable output ...)	
Integrated functions	USB communications	Interface	Personal computer/ Connector mini-USB	
		Communications standard	Compliant with USB 2.0 standard	
		Function	Parameter setting, status monitoring and tuning	
	EtherCAT communications	Communications protocol	IEC 61158 Type 12, IEC 61800-7	
		Physical layer	100BASE-TX (IEEE802.3)	
		Connectors	RJ45 × 2 ECAT IN: EtherCAT input × 1 ECAT OUT: EtherCAT output × 1	
		Communications media	Category 5 or higher (cable with double, aluminium tape and braided shielding is recommended)	
		Communications distance	Distance between nodes: 100 m max.	
		LED indicators	RUN × 1 ERR × 1 L/A IN (Link/Activity IN) × 1 L/A OUT (Link/activity OUT) × 1	
	Autotuning		Automatic motor parameter setting. One parameter rigidity setting. Inertia detection.	
	Dynamic brake (DB)		Built-in. Operates during main power OFF, servo alarm, servo OFF or overtravel.	
	Regenerative processing		Internal resistor included in models from 600 W to 5 kW. Regenerative resistor externally mounted (option).	
	Overtravel (OT) prevention function		DB stop, deceleration stop or coast to stop during P-OT, N-OT operation	
Encoder divider function		Gear ratio		
Protective functions		Overcurrent, overvoltage, undervoltage, overspeed, overload, encoder error, overheat...		
Analog monitor functions for supervision		Analog monitor of motor speed, speed reference, torque reference, command following error, analog input... The monitoring signals to output and their scaling can be specified with parameters. Number of channels: 2 (Output voltage: ±10V DC)		
Panel operator	Display functions	2 × digit 7-segment LED display shows the drive status, alarm codes, parameters...		
	Switches	2 × rotary switches for setting the node address		
CHARGE lamp		Lits when the main circuit power supply is turned ON.		
Safety terminal	Functions	Safety Torque OFF function to cut off the motor current and stop the motor. Output signal for failure monitoring function.		
	Conformed standards	EN ISO13849-1:2008 (PL- d, Performance Level d), IEC61800-5 -2:2007 (function STO, Safe Torque OFF), EN61508:2001 (Safety Integrity Level 2, SIL2), EN954-1:1996 (CAT3).		
External encoder feedback		Serial signal and line-driver A-B-Z encoder for full-closed control		

^{*1} The CSV, CST and Homing modes are supported in the servo drive with version 2.0 or higher.

General specifications (for MECHATROLINK-II servo drives)

Control mode		Position control, velocity control, torque control, full-closed control.	
Performance	Frequency characteristics	2 kHz	
	Speed zero clamp	Preset velocity command can be clamped to zero by the speed zero clamp input.	
	Soft start time setting	0 to 10 s (acceleration, deceleration can be set separately).	
Command input		MECHATROLINK-II commands (for sequence, motion, data setting/reference, monitor, adjustment and other commands)	
I/O signal	Sequence input signal	Multi-function input × 8 by parameter setting (forward/reverse drive prohibition, emergency stop, external latch, origin proximity, forward/reverse torque limit, general purpose monitor input).	
	Sequence output signal	It is possible to output three types of signal form incl.: brake release, servo ready, servo alarm, positioning complete, motor rotation speed detection, torque limit detection, zero speed detection, speed coincidence detection, warning, position command status, speed limit detection, alarm output, speed command status.	
Integrated functions	USB communications	Interface	Personal computer/ Connector mini-USB
		Communications standard	Compliant with USB 2.0 standard
		Function	Parameter setting, status monitoring and tuning
	MECHATROLINK-II communications	Communications protocol	MECHATROLINK-II
		Station address	41H to 51 FH (max. number of slaves: 30)
		Transmission speed	10 Mbps
		Transmission cycle	1, 2 & 4 ms
		Data length	32 bytes
	Autotuning		Automatic motor parameter setting. One parameter rigidity setting. Inertia detection.
	Dynamic brake (DB)		Built-in. Operates during main power OFF, servo alarm, servo OFF or overtravel.
	Regenerative processing		Internal resistor included in models from 600 W to 5 kW. Regenerative resistor externally mounted (option).
	Overtravel (OT) prevention function		DB stop, deceleration stop or coast to stop during P-OT, N-OT operation
	Encoder divider function		Optional division possible
	Protective functions		Overcurrent, overvoltage, undervoltage, overspeed, overload, encoder error, overheat...
	Analog monitor functions for supervision		Analog monitor of motor speed, speed reference, torque reference, command following error, analog input... The monitoring signals to output and their scaling can be specified with parameters. Number of channels: 2 (Output voltage: ±10V DC)
Panel operator	Display functions	2-digit 7-segment LED display shows the drive status, alarm codes, parameters... MECHATROLINK-II communications status LED indicator (COM)	
	Switches	2 × rotary switches for setting the MECHATROLINK-II node address	
CHARGE lamp		Lits when the main circuit power supply is turned ON.	
Safety terminal	Functions	Safety Torque OFF function to cut off the motor current and stop the motor. Output signal for failure monitoring function.	
	Conformed standards	EN ISO13849-1:2008 (PL- d, Performance Level d), IEC61800-5 -2:2007 (function STO, Safe Torque OFF), EN61508:2001 (Safety Integrity Level 2, SIL2), EN954-1:1996 (CAT3).	
External encoder feedback		Serial signal and line-driver A-B-Z encoder for full-closed control	

General specifications (for Analog/pulse servo drives)

Control modes		External control	(1) position control, (2) velocity control, (3) torque control, (4) position/velocity control, (5) position/torque control, (6) velocity/torque control and (7) full-closed control.	
		Internal positioning	Drive Programming: indexer functionality enabled by parameter.	
Speed/torque control	Performance	Frequency characteristics	2 kHz	
		Speed zero clamp	Preset velocity command can be clamped to zero by the speed zero clamp input.	
		Soft start time setting	0 to 10 s (acceleration, deceleration can be set separately). S-curve acceleration/deceleration is also available.	
	Speed control	Speed reference voltage	6 VDC at rated speed: set at delivery (the scale and polarity can be set by parameters)	
		Torque limit	3 VDC at rated torque (torque can be limited separately in positive/negative direction).	
Torque control	Preset speed control	Preset speed is selectable from 8 internal settings by digital inputs.		
	Torque reference voltage	3 VDC at rated torque: set at delivery (the scale and polarity can be set by parameters).		
Position control	Input signal	Speed limit	Speed limit can be set by parameter.	
		Command pulse	Input pulse type	Sign + pulse train, 90° phase displacement 2-phase pulse (A-phase+ B-phase) or CCW/CW pulse train
		Input pulse frequency	4 Mpps max. (200 Kpps max. at open collector).	
Full-closed control	Input signal	Command pulse scaling (Electronic Gear)	Applicable scaling ratio: 1/1000 to 1000 Any value of 1 to 2 ³⁰ can be set for numerator (encoder resolution) and denominator (command pulse resolution per motor revolution). The combination has to be within the range shown above.	
		Command pulse	Input pulse type	Sign + pulse train, 90° phase displacement 2-phase pulse (A-phase+ B-phase) or CCW/CW pulse train
		Input pulse frequency	4 Mpps max. (200 Kpps max. at open collector).	
		Command pulse scaling (Electronic Gear)	Applicable scaling ratio: 1/1000 to 1000 Any value of 1 to 2 ³⁰ can be set for numerator (encoder resolution) and denominator (command pulse resolution). The combination has to be within the range shown above.	
		External encoder scaling	Applicable scaling ratio: 1/20 to 160 Any value of 1 to 2 ³⁰ can be set for numerator (encoder resolution) and denominator (external encoder resolution per motor revolution). The combination has to be within the range shown above.	
Drive Programming	Functionality selection		Functionality enabled by parameter.	
	Supported functionality		G5 Analogue/pulse servo drive with firmware 1.10 or higher.	
	Software		CX-Drive version 2.30 or higher.	
	Communication		The program can be downloaded via USB communication (CX-Drive)	
	Command types		Move relative, Move absolute, Jog, Homing, Deceleration stop, Velocity update, Timer, Output signal control, Jump, Conditional branching,	
	Number of commands		Up to 32 commands (0 to 31)	
	Command execution		Strobe input to execute the selected command or to execute a complex sequence (combination of various commands).	
Command selection		Up to 5 digital inputs to select the individual commands or sequences		

I/O signal	Position signal output	A-phase, B-phase, Z-phase line driver output and Z-phase open-collector output.	
	Sequence input signal	External control	- Multi-function input × 10 by parameter setting: servo ON, control mode switching, forward/reverse drive prohibition, vibration filter switching, gain switching, electronic gear switching, error counter reset, pulse prohibition, alarm reset, internal speed selection, torque limit switching, zero speed, emergency stop, inertia ratio switching, velocity/torque command sign. - Dedicated input × 1 (SEN: sensor ON, ABS data request).
		Internal positioning (Drive programming mode)	- Multi-function input × 10 by parameter setting: servo ON, forward/reverse drive prohibition, damping filter switching, gain switching, alarm reset, torque limit switching, emergency stop, immediate stop, deceleration stop input, inertia ratio switching, latch input, origin proximity input, strobe and 5 × input command selection. - Dedicated input × 1 (SEN: sensor ON, ABS data request).
	Sequence output signal	External control	- 3 × outputs signals configured by parameter settings: brake release, servo ready, servo alarm, positioning complete, motor rotation speed detection, torque limit detection, zero speed detection, speed coincidence detection, warning, position command status, speed limit detection, speed command status. - 1 output fixed to Alarm output.
Internal positioning (Drive programming enabled)		3 × outputs signals configured by parameter settings: ready, Brake, position completed, motor speed detection, torque limit status, zero speed detection, speed conformity, warning, position command status, position completed, drive programming command output and output during drive programming. - 1 output fixed to Alarm output.	
Integrated functions	USB Communications	Interface: Personal computer/ Connector mini-USB Communications standard: Compliant with USB 2.0 standard Function: Parameter setting, status monitoring and tuning	
	Autotuning	Automatic motor parameter setting. One parameter rigidity setting. Inertia detection.	
	Dynamic brake (DB)	Built-in. Operates during main power OFF, servo alarm, servo OFF or overtravel.	
	Regenerative processing	Internal resistor included in models from 600 W to 5 kW. Regenerative resistor externally mounted (option).	
	Overtravel (OT) prevention function	DB stop, deceleration stop or coast to stop during P-OT, N-OT operation	
	Encoder divider function	Optional division possible	
	Electronic gearing (Numerator/Denominator)	Up to 4 electronic gear numerators by combining with inputs.	
	Internal speed setting function	8 speeds may be set internally	
	Protective functions	Overcurrent, overvoltage, undervoltage, overspeed, overload, encoder error, overheat...	
	Analog monitor functions for supervision	Analog monitor of motor speed, speed reference, torque reference, command following error, analog input... The monitoring signals to output and their scaling can be specified by parameters. Number of channels: 2 (Output voltage: ±10V DC)	
	Panel operator	Display functions	6-digit 7-segment LED display shows the drive status, alarm codes, parameters...
		Panel operator keys	Used to set/monitor parameters and drive condition (5 key switches).
	CHARGE lamp	Lits when the main circuit power supply is turned ON.	
	Safety terminal	Functions	Safety torque OFF function to cut off the motor current and stop the motor. Output signal for failure monitoring function.
		Conformed standards	EN ISO13849-1:2008 (PL- d, Performance Level d), IEC61800-5 -2:2007 (function STO, Safe Torque OFF), EN61508:2001 (Safety Integrity Level 2, SIL2), EN954-1:1996 (CAT3).
External encoder feedback	Serial signal and line-driver A-B-Z encoder for full-closed control		
Expansion connector	Serial bus for option board		

Servo drive part names

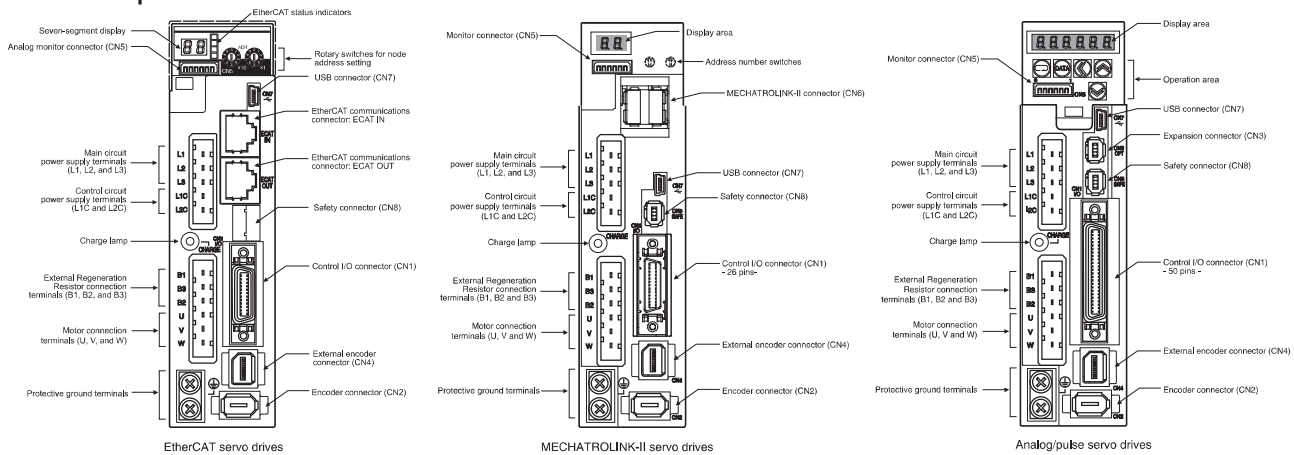

Note: The above pictures show 230 V servo drives models only. The 400 V servo drives have 24 VDC power input terminals for control circuit instead of L1C and L2C terminals.

I/O specifications

Terminals specifications (for all servo drives)

Symbol	Name	Function
L1	Main power supply input terminal	AC power input terminals for the main circuit Note: for single-phase servo drives connect the power supply input to L1 and L3.
L2		
L3		
L1C	Control power supply input terminal	AC power input terminals for the control circuit (for 200 V single/three-phase servo drives only). DC power input terminals for the control circuit (for 400 V three-phase servo drives only).
L2C		
24 V 0 V		
B1	External regeneration resistor connection terminals	Servo drives 200 V below 750 W: no internal resistor is connected. Leave B2 and B3 open. Connect an external regenerative resistor between B1 and B2. Servo drives from 600 W to 5 kW: short-circuit in B2 and B3 for internal regenerative resistor. If the internal regenerative resistor is insufficient, connect an external regenerative resistor between B1 and B2 and remove the wire between B2 and B3.
B2		
B3		
U	Servo motor connection terminals	Terminals for outputs to the servomotor.
V		
W		

I/O signals (CN1) - Input signals (for EtherCAT and MECHATROLINK-II servo drives)

Pin No.	Signal name	Function	
6	I-COM	± pole of external DC power. The power must use 12 V to 24 V (±5%)	The signal name shows the factory setting. The function can be changed by parameter setting.
5	E-STOP	Emergency stop	
7	P-OT	Forward run prohibited	
8	N-OT	Reverse run prohibited	
9	DEC	Origin proximity	
10	EXT3	External latch input 3	
11	EXT2	External latch input 2	
12	EXT1	External latch input 1	
13	SI-MON0	General purpose monitor input 0	
14	BTP-I	Connecting pin for the absolute encoder backup battery. Do not connect when a battery is connected to the encoder cable (CN2 connector).	
15	BTN-I		
17	–	Terminals not used. Do not connect.	
18	–		
19	–		
20	–		
21	–		
22	–		
23	–		
24	–		
–	PCL	Forward torque limit	The function of input signals allocated to pins 5 and 7 to 13 can be changed with these options by parameters settings.
	NCL	Reverse torque limit	
	SI-MON1	General-purpose monitor input 1	
	SI-MON2	General-purpose monitor input 2	
Shell	FG	Shield ground. Connected to frame ground if the shield wire of the I/O signal cable is connected to the connector shell.	
16	GND	Signal ground. It is insulated with power supply (I-COM) for the control signal in the servo drive.	

I/O signals (CN1) - Output signals (for EtherCAT and MECHATROLINK-II servo drives)

Pin No.	Signal name	Function	
1	BRK-OFF+	External brake release signal	The function of output signals allocated to pins 1, 2, 25 and 26 can be changed with these options by parameters settings
2	BRK-OFF		
25	S-RDY+	Servo ready: ON when there is no servo alarm and control/main circuit power supply is ON	
26	S-RDY–		
3	ALM+	Servo alarm: Turns OFF when an error is detected	
4	ALM–		
–	INP1	Position completed output 1	
	TGON	Speed detection	
	T_LIM	Torque limit	
	ZSP	Zero speed	
	VCMP	Speed command status	
	INP2	Position completed output 2	
	WARN1	Warning 1	
	WARN2	Warning 2	
	PCMD	Position command status	
	V_LIM	Speed limit	
	ALM-ATB	Error clear attribute (for ECT model only)	
	R-OUT1	Programmable output 1 (for ECT model only)	
	R-OUT2	Programmable output 2 (for ECT model only)	

I/O signals (CN1) - Input signals (for Analog/pulse servo drives)

Pin No.	Control mode	Signal name	Function	
1	Position/ Full closed loop	+24 V CW	Reference pulse input for line driver and open collector according to parameter setting. Input mode: Sign + pulse string Reverse/forward pulse (CCW/CW pulse) Two-phase pulse (90° phase differential)	
3		+CW		
4		-CW		
2		+24 V CCW		
5		+CCW		
6		-CCW		
44		+CWLD	Reference pulse input for line driver only. Input mode: Reverse/forward pulse (CCW/CW pulse)	
45		-CWLD		
46		+CCWLD		
47		-CCWLD		
14	Speed	REF	Speed reference input: ±10 V/rated motor speed (input gain can be modified using a parameter).	
	Torque	TREF1	Torque reference input: ±10 V/rated motor torque (input gain can be modified using a parameter).	
		VLIM	Speed limit input: ±10 V/rated motor speed (input gain can be modified using a parameter).	
15	-	AGND1	Analog signal ground	
16	Torque	TREF2	Torque reference input: ±10 V/rated motor torque (input gain can be modified using a parameter).	
	Position/Speed	PCL	Forward torque limit input: ±10 V/rated motor torque (input gain can be modified using a parameter).	
18	Full closed loop	NCL	Reverse torque limit input: ±10 V/rated motor torque (input gain can be modified using a parameter).	
17	-	AGND1	Analog signal ground	
7	Common	+24 VIN	Control power supply input for sequence signals: users must provide the +24 V power supply (12 to 24 V).	
29		RUN	Servo ON: this turn ON the servo.	
26	Position/Full closed loop	DFSEL1	Vibration filter switching 1	Enables vibration filter according parameter setting.
27	Common	GSEL	Gain switching	Enables gain value according parameter setting.
28	Position/Full closed loop	GESEL1	Electronic gear switching 1	Switches the numerator fro electronic gear ratio.
	Speed	VSEL3	Internal speed selection 3	Input to select the desired speed setting during internally speed operation. The speed selection is combining this input with VSEL1 and VSEL2 inputs.
30	Position/Full closed loop	ECRST	Error counter reset input.	Resets the position error counter.
	Speed	VSEL2	Internal speed selection 2	Input to select the desired speed setting during internally speed operation. The speed selection is combining this input with VSEL1 and VSEL3 inputs.
31	Common	RESET	Alarm reset input.	Release the alarm status. The error counter is reset when the alarm is reset.
32	Position/Speed/ Torque	TVSEL	Control mode switching	Position ↔ speed
				Position ↔ torque
				Torque ↔ speed

I/O signals (CN1) - Output signals (for Analog/pulse servo drives)

Pin No.	Control mode	Signal name	Function
21	Position/ Full closed loop	+A	Encoder phase A+
22		-A	Encoder phase A-
48		+B	Encoder phase B+
49		-B	Encoder phase B-
23		+Z	Encoder phase Z+
24		-Z	Encoder phase Z-
19		Z	Encoder phase-Z output
25	ZCOM	Encoder phase-Z common	Encoder signals (or external scale signals during full closing control) are output according Encoder Dividing Numerator parameter. This is the line-driver output (equivalent to R422). The maximum output frequency is 4 Mbps. Phase Z is output for encoder signals (or external scale signals during full closing control). This is the line-driver output (equivalent to R422). Phase Z is output for encoder signals (or external scale signals during full closing control). Open-collector output.
11	Common	BKIR	Brake release signal output
10		BKIRCOM	Timing signal for operating the electromagnetic brake on a motor.
35		READY	Servo ready: ON if there is not servo alarm when the control/main circuit power supply is turned ON.
34		READYCOM	
37		/ALM	Servo alarm: turns OFF when an error is detected.
36		ALMCOM	
39	Speed/torque	TGON	Motor rotation speed detection. This output turns ON when the motor rotation speed reaches the speed set in a parameter.
39	Position/ Full closed loop	INP1	Positioning complete output 1: turns ON when position error is equal to setting parameter.
38		INP1COM	
-	-	INP2	Position complete output 2
		P-CMD	Position command status
		ZSP	Zero speed
		WARN1	Warning 1
		WARN2	Warning 2
		ALM-ATB	Error clear attribute
		VCMP	Speed conformity output
		V-CMD	Speed command status
		V-LIMIT	Speed limit detection
		T-LIMIT	Torque limit detection
	Drive Programming	B-CTRL1	Drive Programming output 1
		B-CTRL2	Drive Programming output 2
		B-CTRL3	Drive Programming output 3
		B-BUSY	Output during Drive Programming
		HOME-CMP	Origin search complete

The function of output signals allocated to pins 11, 10, 34 to 39 can be changed with these options by parameters settings.

External encoder connector (CN4) - (for all servo drives)

Pin No.	Signal name	Function
1	E5V	External scale power supply output. Use at 5.2 V ±5% and at or below 250 mA.
2	E0V	This is connected to the control circuit ground connected to connector CN1.
3	PS	External scale signal I/O (serial signal).
4	/PS	
5	EXA	External scale signal input (Phase A, B, and Z signals). Performs the input and output of phase A, B and Z signals.
6	/EXA	
7	EXB	
8	/EXB	
9	EXZ	
10	/EXZ	
Shell	FG	Shield ground

Monitor connector (CN5) - (for all servo drives)

Pin No.	Signal name	Function
1	AM1	Analog monitor output 1. Outputs the analog signal for the monitor. Use the parameters setting to select the output to monitor. Default setting: Motor rotation speed 1 V/(1000 r/min).
2	AM2	Analog monitor output 2. Outputs the analog signal for the monitor. Use the parameters setting to select the output to monitor. Default setting: Motor rotation speed 1 V/(1000 r/min).
3	GND	Ground for analog monitors 1, 2.
4	-	Terminals not used. Do not connect.
5	-	
6	-	

Safety connector (CN8) - (for all servo drives)

Pin No.	Signal name	Function
1	-	Not used. Do not connect
2	-	
3	SF1-	Safety input 1 & 2. This input turns OFF the power transistor drive signals in the servo drive to cut off the current output to the motor.
4	SF1+	
5	SF2-	
6	SF2+	
7	EDM-	A monitor signal is output to detect a safety function failure.
8	EDM+	
Shell	FG	Frame ground.

Dimensions

Servo drives

R88D-KT01/02H, R88D-KN01/02H-□ (230 V, 100 to 200 W)

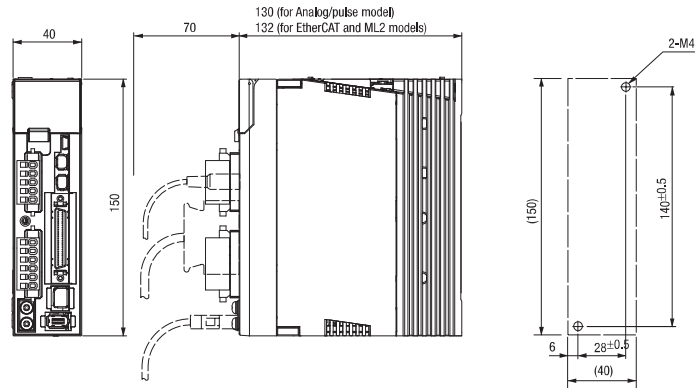

R88D-KT04H, R88D-KN04H-□ (230 V, 400 W)

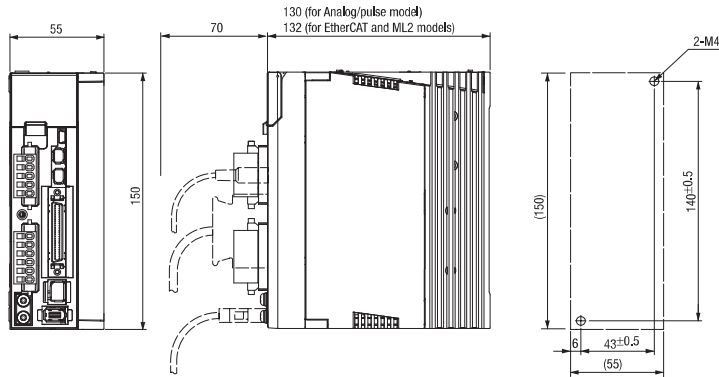

R88D-KT08H, R88D-KN08H-□ (230 V, 750 W)

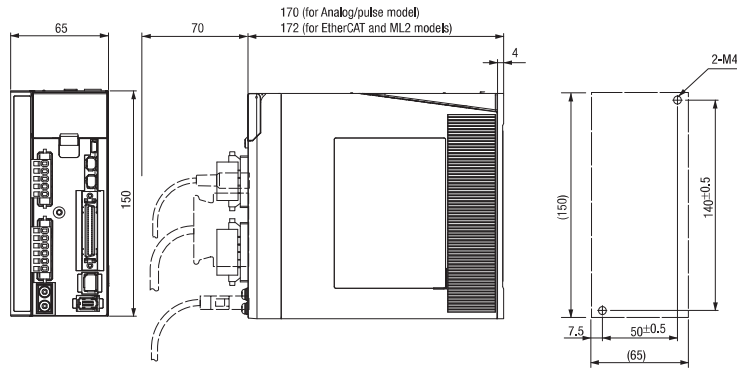

R88D-KT10/15H, R88D-KN10/15H-□ (230 V, 1 to 1.5 kW)

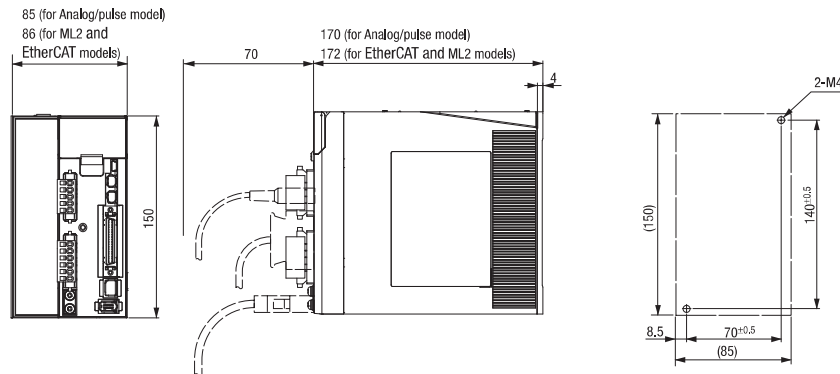

R88D-KT06/10/15F, R88D-KN06/10/15F-□ (400 V, 600 W to 1.5 kW)

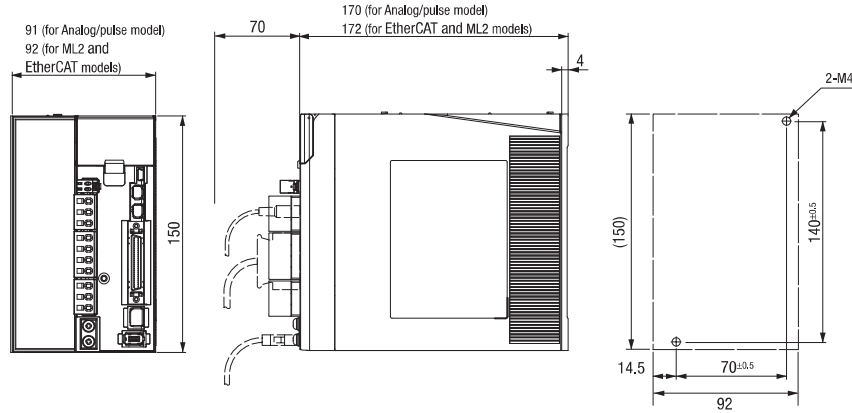

R88D-KT20F, R88D-KN20F-□ (400 V, 2 kW)

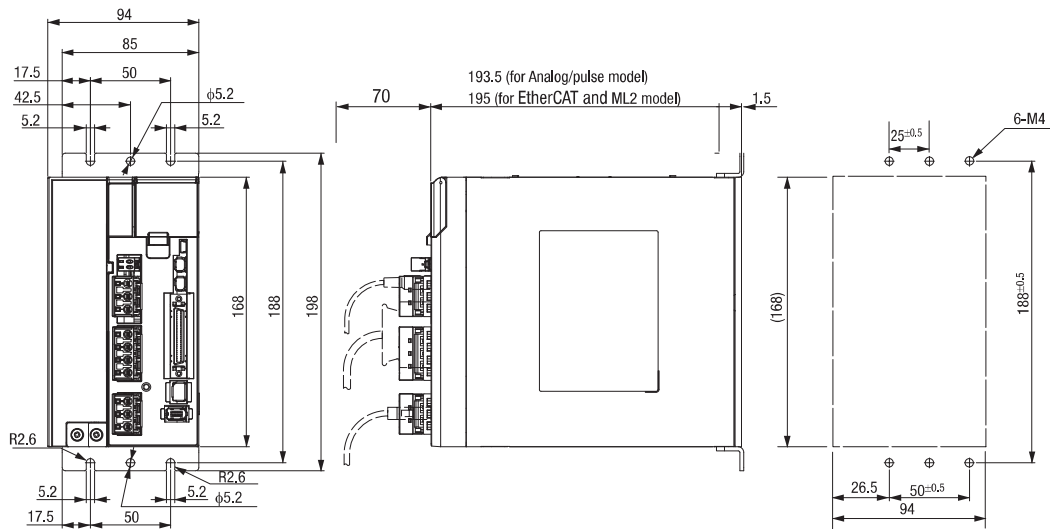

R88D-KT30/50F, R88D-KN30/50F-□ (400 V, 3 to 5 kW)

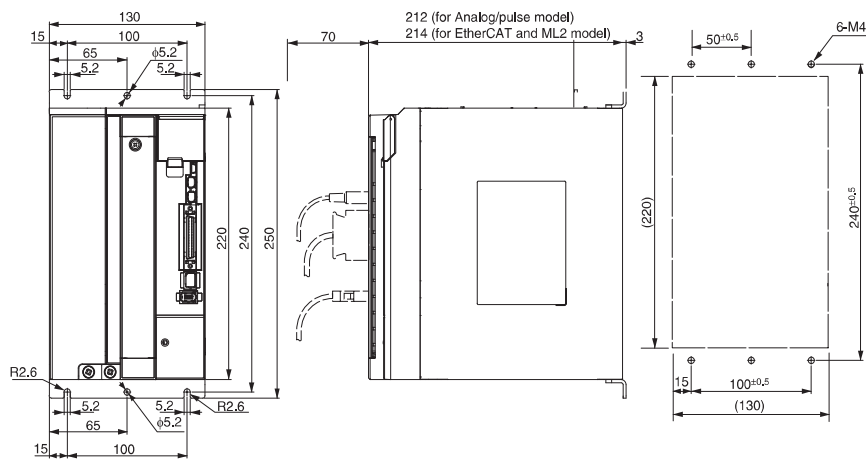

R88D-KT75F, R88D-KN75H-ECT (400 V, 7.5 kW)

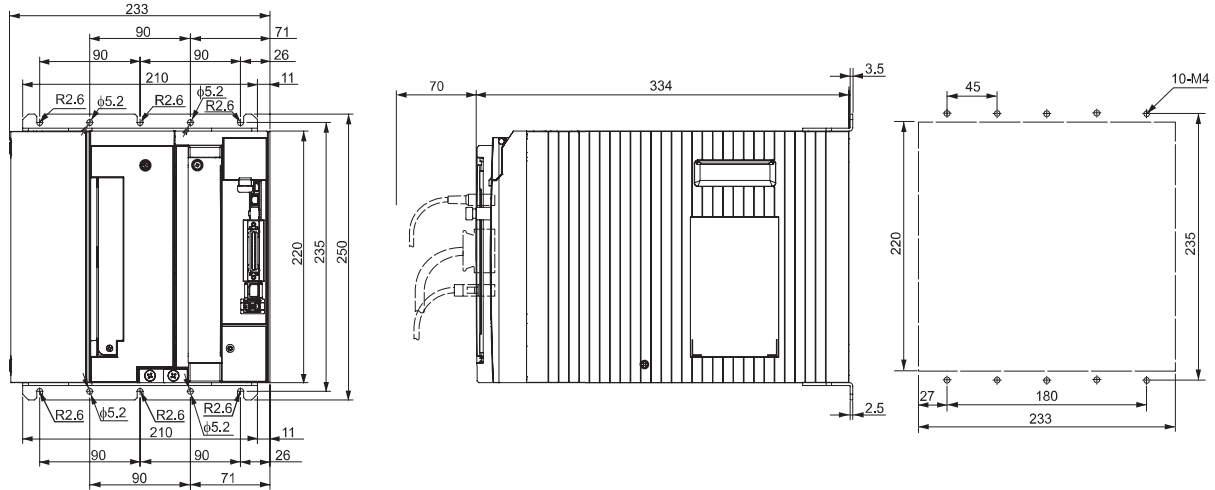

R88D-KT150F, R88D-KN150H-ECT (400 V, 15 kW)

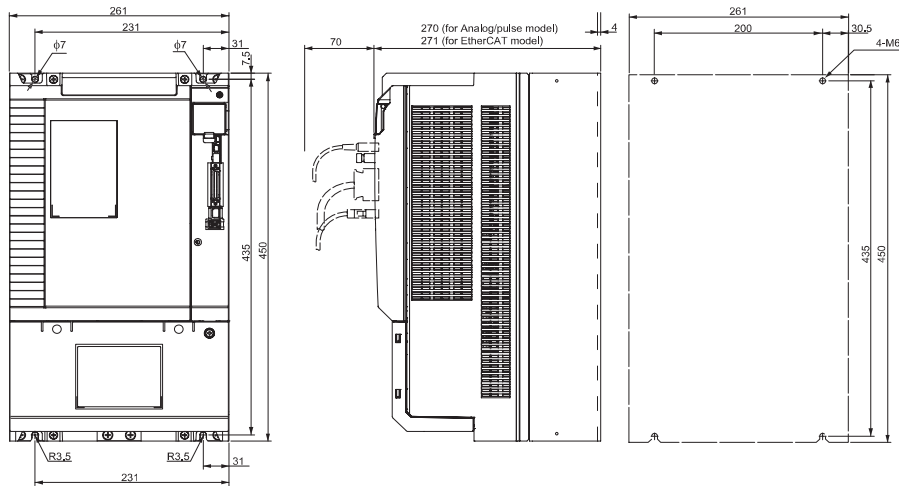

Filters

Filter model	External dimensions			Mount dimensions	
	H	W	D	M1	M2
R88A-FIK102-RE	190	42	44	180	20
R88A-FIK104-RE	190	57	30	180	30
R88A-FIK107-RE	190	64	35	180	40
R88A-FIK114-RE	190	86	35	180	60
R88A-FIK304-RE	196	92	40	186	70
R88A-FIK306-RE	238	94	40	228	70
R88A-FIK312-RE	291	130	40	278	100
R88A-FIK330-RE	310	233	50	293	180
R88A-FIK350-RE	506	261	52	491	200

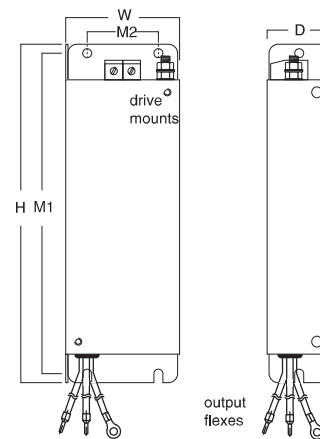

Installation

Single-phase, 230 VAC (for EtherCAT and MECHATROLINK-II servo drives)

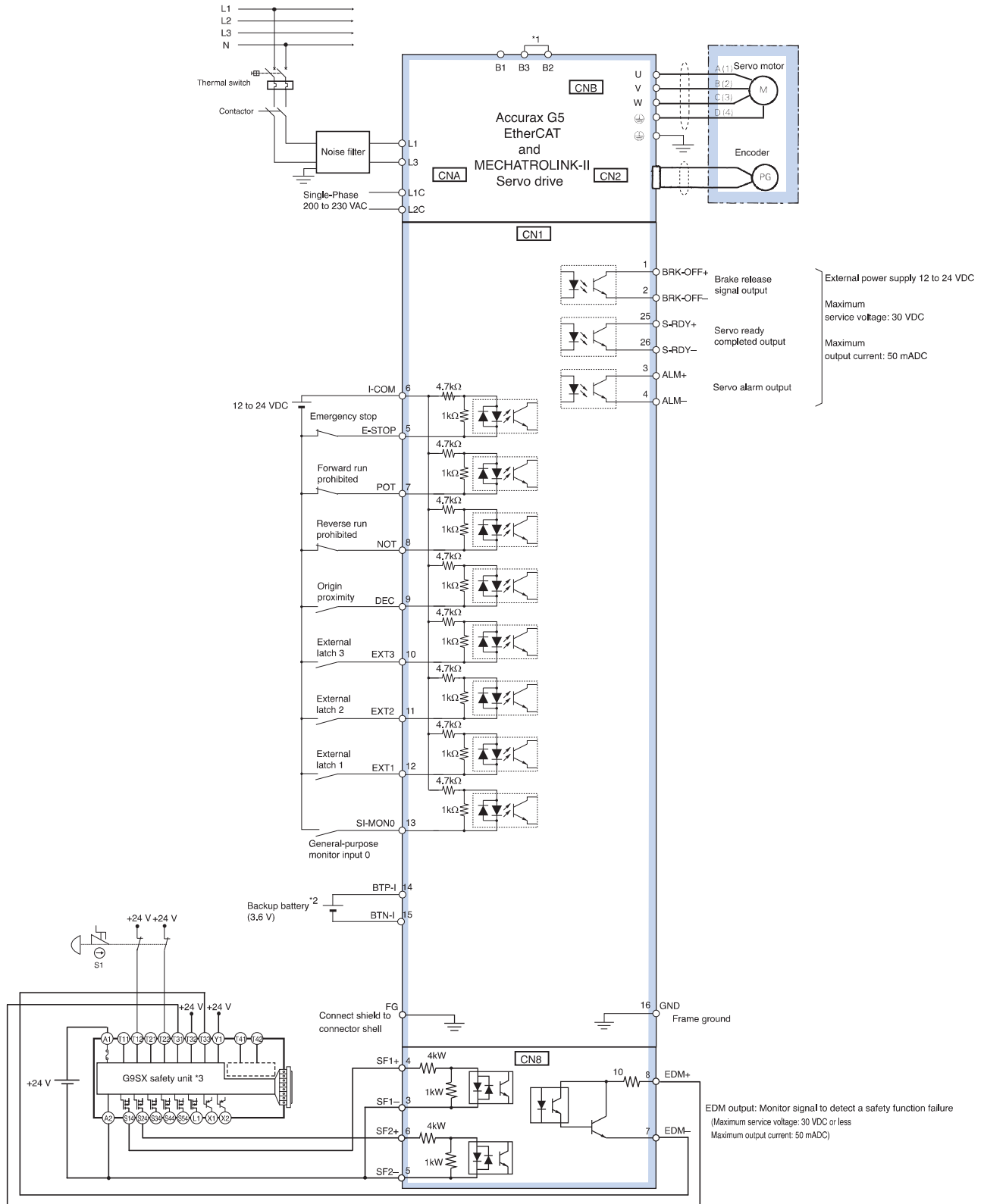

*1 For servo drives from 750 W, B2 and B3 are short-circuited. If the internal regenerative resistor is insufficient, remove the wire between B2 and B3 and connect an external regenerative resistor between B1 and B2.

*2 For use only with an absolute encoder. If a backup battery is connected to CN1 I/O connector, an encoder cable with a battery is not required.

*3 Wiring diagram example using the G9SX safety unit. If a safety unit is not used, keep the factory safety bypass connector installed in the CN8.

Note: The input function of pins 5 and 7 to 13, and output function of pins 1, 2, 25 and 26, can be changed via parameter settings.

Three-phase, 400 VAC (for EtherCAT and MECHATROLINK-II servo drives)

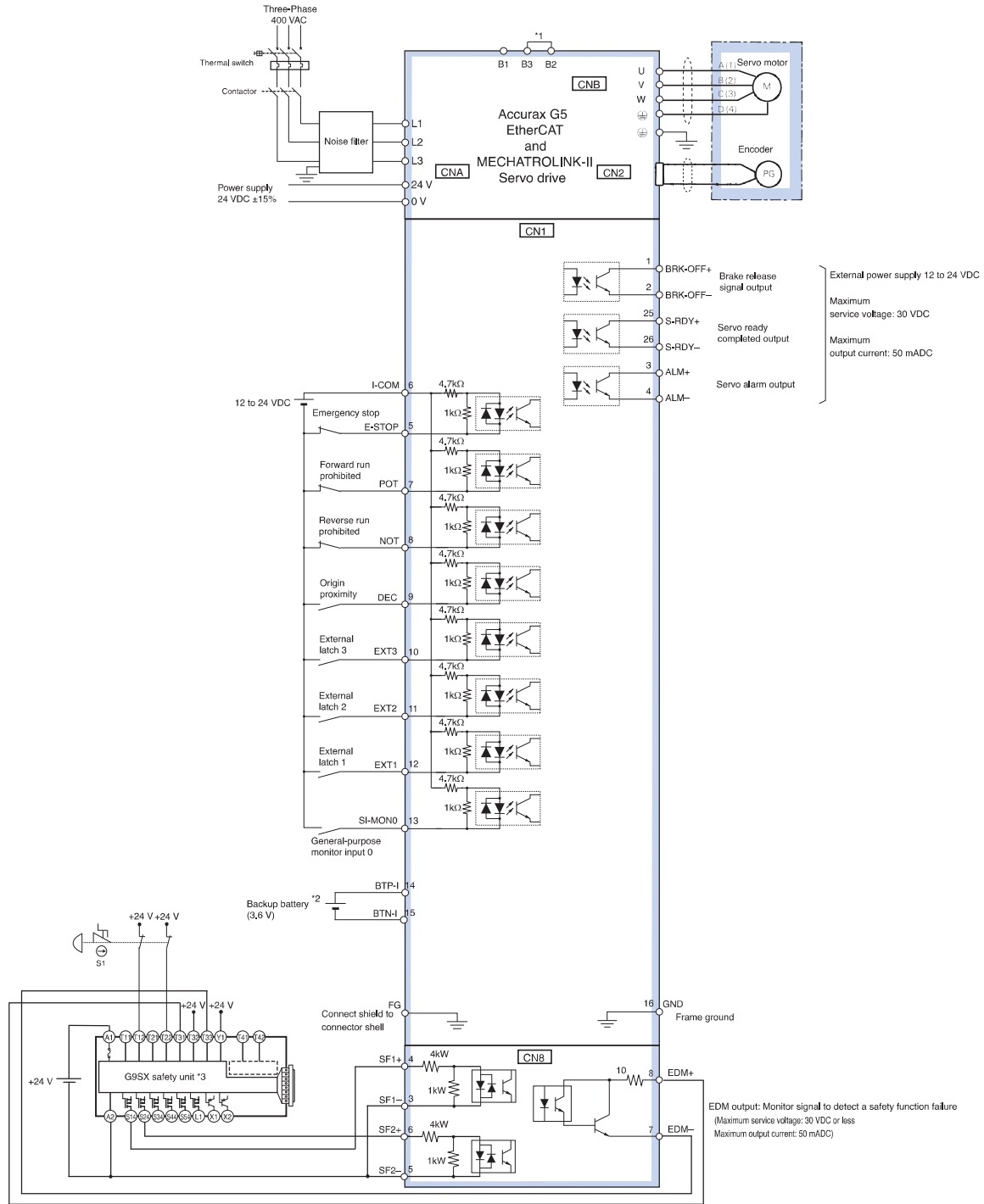

*1 Normally B2 and B3 are short-circuited. If the internal regenerative resistor is insufficient, remove the wire between B2 and B3 and connect an external regenerative resistor between B1 and B2.

*2 For use only with an absolute encoder. If a backup battery is connected to CN1 I/O connector, an encoder cable with a battery is not required.

*3 Wiring diagram example using the G9SX safety unit. If a safety unit is not used, keep the factory safety bypass connector installed in the CN8.

Note: The input function of pins 5 and 7 to 13, and output function of pins 1, 2, 25 and 26, can be changed via parameter settings.

Single-phase, 230 VAC (for Analog/pulse servo drives)

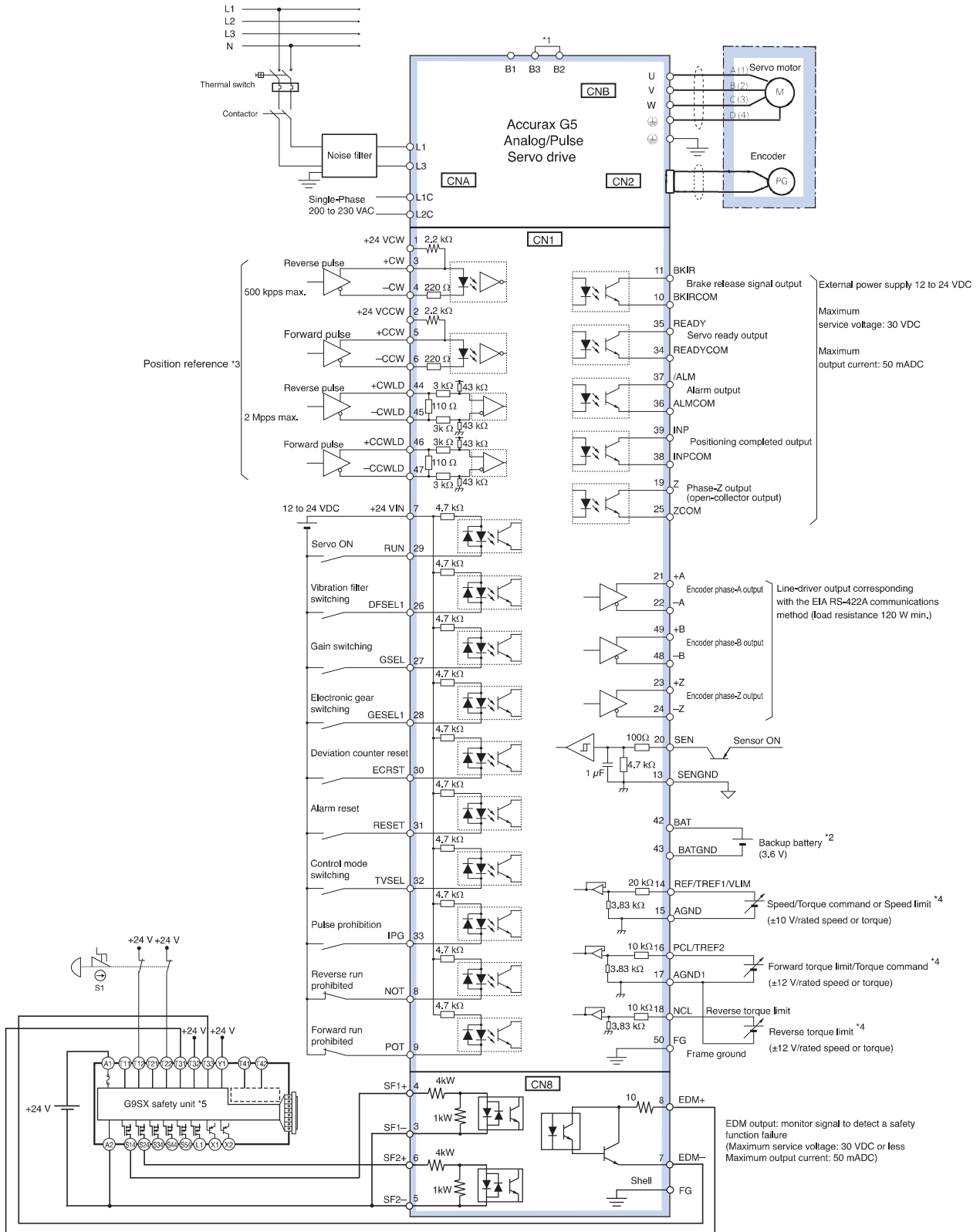

*1 For servo drives from 750 W, B2 and B3 are short-circuited. If the internal regenerative resistor is insufficient, remove the wire between B2 and B3 and connect an external regenerative resistor between B1 and B2.
 *2 For use only with an absolute encoder. If a backup battery is connected to CN1 I/O connector, an encoder cable with a battery is not required.
 *3 Only available in Position control mode.
 *4 The input function depends on control mode used (Position, speed or torque control).
 *5 Wiring diagram example using the G9SX safety unit. If a safety unit is not used, keep the factory safety bypass connector installed in the CN8.

Note: The input function of pins 8, 9 and 26 to 33, and output function of pins 10, 11, 34, 35, 38 and 39, can be changed via parameter settings.

Three-phase, 400 VAC (for Analog/pulse servo drives)

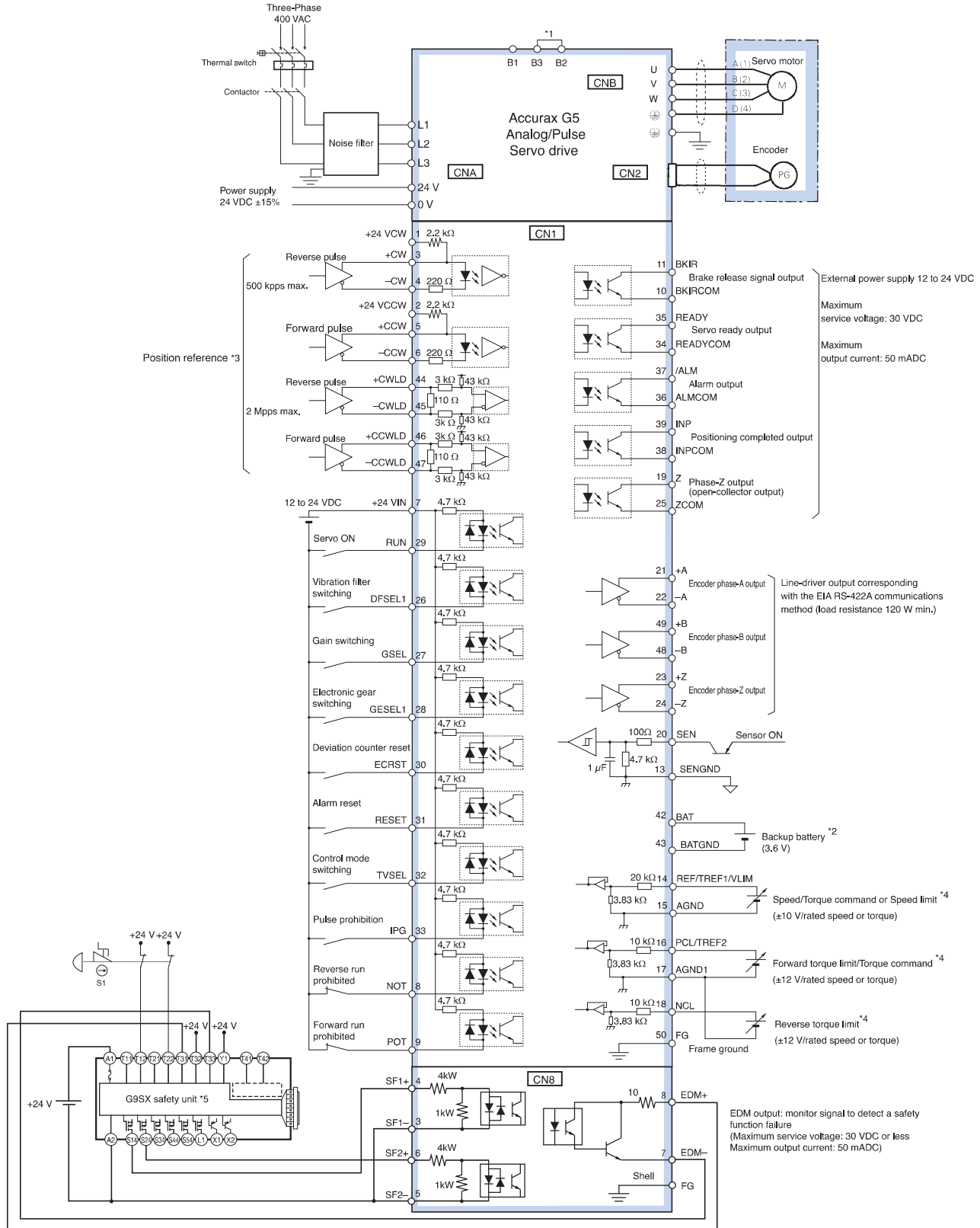

*1 Normally B2 and B3 are short-circuited. If the internal regenerative resistor is insufficient, remove the wire between B2 and B3 and connect an external regenerative resistor between B1 and B2.
 *2 For use only with an absolute encoder. If a backup battery is connected to CN1 I/O connector, an encoder cable with a battery is not required.
 *3 Only available in Position control mode.
 *4 The input function depends on control mode used (Position, speed or torque control).
 *5 Wiring diagram example using the G9SX safety unit. If a safety unit is not used, keep the factory safety bypass connector installed in the CN8.

Note: The input function of pins 8,9 and 26 to 33, and output function of pins 10, 11, 34, 35, 38 and 39, can be changed via parameter settings.

Ordering information

Accurax G5 series EtherCAT reference configuration

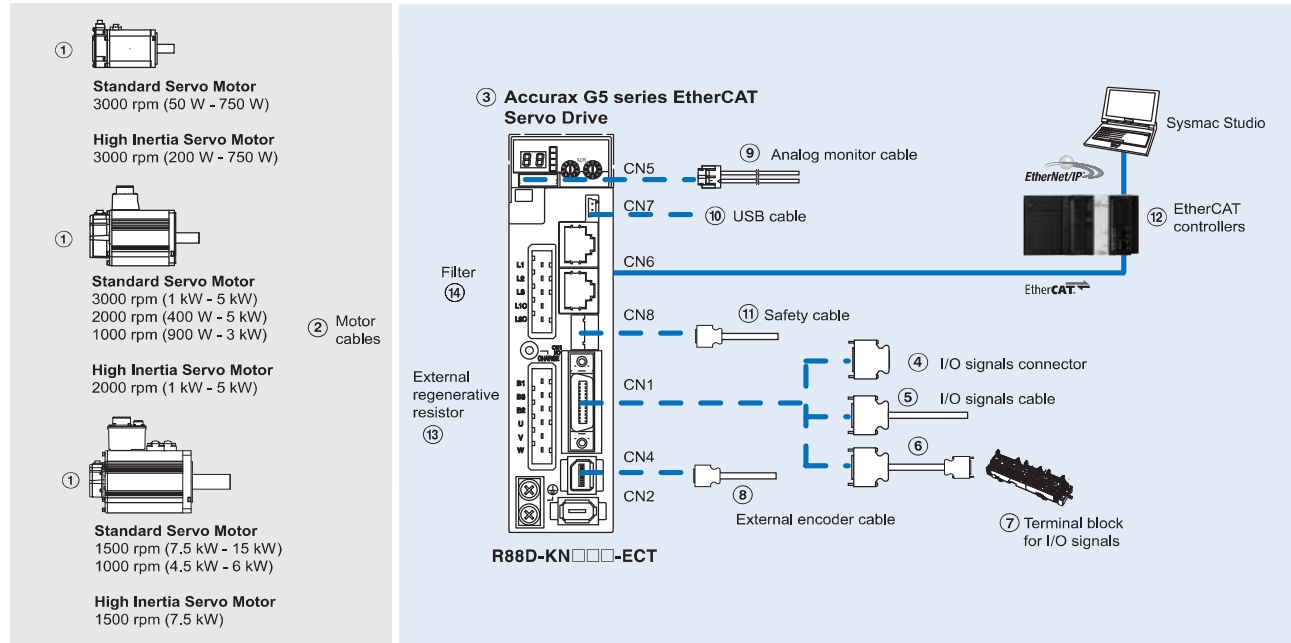

Note: The symbols ①②③④⑤... show the recommended sequence to select the components in Accurax G5 servo system

Servo motors, power & encoder cables

Note: ①② Refer to the Accurax G5 servo motor chapter for servomotor, motor cables or connectors selection

Servo drives

Symbol	Specifications		Servo drive models	① Compatible G5 series rotary servo motors	
				Standard models	High Inertia models
③	1 phase 230 VAC	100 W	R88D-KN01H-ECT	R88M-K05030(H/T)-□	-
			R88D-KN02H-ECT	R88M-K20030(H/T)-□	R88M-KH20030(H/T)-□
			R88D-KN04H-ECT	R88M-K40030(H/T)-□	R88M-KH40030(H/T)-□
			R88D-KN08H-ECT	R88M-K75030(H/T)-□	R88M-KH75030(H/T)-□
			R88D-KN10H-ECT	R88M-K1K020(H/T)-□	-
			R88D-KN15H-ECT	R88M-K1K030(H/T)-□	-
			R88D-KN15H-ECT	R88M-K1K530(H/T)-□	-
	3 phase 400 VAC	600 W	R88D-KN06F-ECT	R88M-K40020(F/C)-□	-
			R88D-KN10F-ECT	R88M-K60020(F/C)-□	-
			R88D-KN15F-ECT	R88M-K75030(F/C)-□	-
			R88D-KN15F-ECT	R88M-K1K020(F/C)-□	R88M-KH1K020(F/C)-□
			R88D-KN15F-ECT	R88M-K1K030(F/C)-□	-
			R88D-KN15F-ECT	R88M-K1K530(F/C)-□	-
			R88D-KN15F-ECT	R88M-K1K520(F/C)-□	R88M-KH1K520(F/C)-□
3 phase 400 VAC	2.0 kW	R88D-KN20F-ECT	R88M-K90010(F/C)-□	-	
		R88D-KN20F-ECT	R88M-K2K030(F/C)-□	-	
		R88D-KN30F-ECT	R88M-K2K020(F/C)-□	R88M-KH2K020(F/C)-□	
		R88D-KN30F-ECT	R88M-K3K030(F/C)-□	-	
		R88D-KN30F-ECT	R88M-K3K020(F/C)-□	R88M-KH3K020(F/C)-□	
		R88D-KN30F-ECT	R88M-K2K010(F/C)-□	-	
		R88D-KN50F-ECT	R88M-K4K030(F/C)-□	-	
3 phase 400 VAC	7.5 kW	R88D-KN75F-ECT	R88M-K5K030(F/C)-□	-	
		R88D-KN75F-ECT	R88M-K4K020(F/C)-□	R88M-KH4K020(F/C)-□	
		R88D-KN75F-ECT	R88M-K5K020(F/C)-□	R88M-KH5K020(F/C)-□	
		R88D-KN75F-ECT	R88M-K4K510C-□	-	
		R88D-KN75F-ECT	R88M-K3K010(F/C)-□	-	
		R88D-KN75F-ECT	R88M-K6K010C-□	-	
		R88D-KN75F-ECT	R88M-K7K515C-□	R88M-KH7K515C-□	
3 phase 400 VAC	15 kW	R88D-KN150F-ECT	R88M-K1K1015C-□	-	
		R88D-KN150F-ECT	R88M-K15K015C-□	-	

Signals cables for I/O general purpose (CN1)

Symbol	Description	Connect to	Model
④	I/O connector kit (26 pins)	For I/O general purpose	– R88A-CNW01C
⑤	I/O signals cable	For I/O general purpose	1 m R88A-CPKB001S-E
			2 m R88A-CPKB002S-E
⑥	Terminal block cable	For I/O general purpose	1 m XW2Z-100J-B34
			2 m XW2Z-200J-B34
⑦	Terminal block (M3 screw and for pin terminals)	–	XW2B-20G4
	Terminal block (M3.5 screw and for fork/round terminals)	–	XW2B-20G5
	Terminal block (M3 screw and for fork/round terminals)	–	XW2D-20G6

External encoder cable (CN4)

Symbol	Name		Model
⑧	External encoder cable	5 m	R88A-CRKM005SR-E
		10 m	R88A-CRKM010SR-E
		20 m	R88A-CRKM020SR-E

Analog monitor (CN5)

Symbol	Name		Model
⑨	Analog monitor cable	1 m	R88A-CMK001S

USB personal computer cable (CN7)

Symbol	Name		Model
⑩	USB mini-connector cable	2 m	AX-CUSBM002-E

Cable for safety (CN8)

Symbol	Name		Model
⑪	Safety cable	3 m	R88A-CSK003S-E

EtherCAT controllers

Symbol	Name		Model
⑫	NJ-series	CPU unit	NJ501-1500 (64 axes)
			NJ501-1400 (32 axes)
			NJ501-1300 (16 axes)
			NJ301-1200 (8 axes)
		NJ301-1100 (4 axes)	
		Power supply unit	NJ-PA3001 (220 VDC)
	NJ-PD3001 (24 VDC)		
	Trajexia stand-alone	Motion control unit	TJ2-MC64 (64 axes)
			EtherCAT master unit
	Position controller unit for CJ1 PLC series	TJ2-ECT64 (64 axes)	TJ2-ECT16 (16 axes)
			TJ2-ECT04 (4 axes)
			CJ1W-NCF8□ (16 axes)
CJ1W-NC88□ (8 axes)			
CJ1W-NC48□ (4 axes)			
CJ1W-NC281 (2 axes)			

External regenerative resistor

Symbol	Regenerative resistor unit model	Specifications
⑬	R88A-RR08050S	50 Ω, 80 W
	R88A-RR080100S	100 Ω, 80 W
	R88A-RR22047S	47 Ω, 220 W
	R88A-RR50020S	20 Ω, 500 W

Filters

Symbol	Applicable servodrive	Filter model	Manufacturer	Rated current	Leakage current	Rated voltage
⑭	R88D-KN01H-ECT, R88D-KN02H-ECT	R88A-FIK102-RE	Rasmi Electronics Ltd	2.4 A	3.5 mA	250 VAC single-phase
	R88D-KN04H-ECT	R88A-FIK104-RE		4.1 A	3.5 mA	
	R88D-KN08H-ECT	R88A-FIK107-RE		6.6 A	3.5 mA	
	R88D-KN10H-ECT, R88D-KN15H-ECT	R88A-FIK114-RE		14.2 A	3.5 mA	
	R88D-KN06F-ECT, R88D-KN10F-ECT, R88D-KN15F-ECT	R88A-FIK304-RE		4 A	0.3 mA / 32 mA ^{*1}	400 VAC three-phase
	R88D-KN20F-ECT	R88A-FIK306-RE		6 A	0.3 mA / 32 mA ^{*1}	
	R88D-KN30F-ECT, R88D-KN50F-ECT	R88A-FIK312-RE		12.1 A	0.3 mA / 32 mA ^{*1}	
	R88D-KN75F-ECT	R88A-FIK330-RE		22 A	0.3 mA / 40 mA ^{*1}	
	R88D-KN150F-ECT	R88A-FIK350-RE		44 A	2 mA / 130 mA ^{*1}	

*1 Momentary peak leakage current for the filter at switch-on/off.

Connectors

Specifications	Model
External encoder connector (for CN4)	R88A-CNK41L
Safety I/O signal connector (for CN8)	R88A-CNK81S

Computer software

Specifications	Model
Sysmac Studio version 1.0 or higher	SYSMAC-SE2□□□
CX-Drive version 2.10 or higher	CX-DRIVE 2.10
CX-One software package including CX-Drive 2.10 or higher	CX-ONE

Note: If CX-One is installed on the same computer as Sysmac Studio, it must be CX-One v4.2 or higher

Ordering information

Accurax G5 series MECHATROLINK-II reference configuration

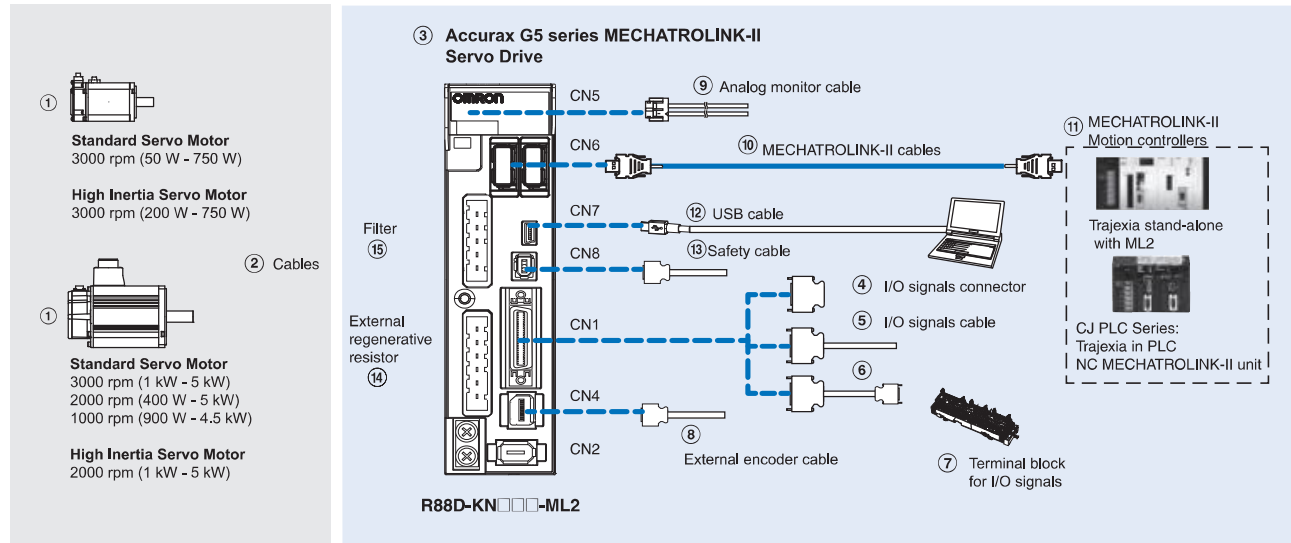

Note: The symbols ①②③④⑤... show the recommended sequence to select the components in Accurax G5 servo system

Servo motors, power & encoder cables

Note: ①② Refer to the Accurax G5 servo motor chapter for servomotor, motor cables or connectors selection

Servo drives

Symbol	Specifications		Servo drive models	① Compatible G5 series rotary servo motors		
				Standard models	High inertia models	
③	1 phase 230 VAC	100 W	R88D-KN01H-ML2	R88M-K05030(H/T)-□	-	
			R88D-KN02H-ML2	R88M-K20030(H/T)-□	-	
			R88D-KN04H-ML2	R88M-K40030(H/T)-□	R88M-KH40030(H/T)-□	
		400 W	R88D-KN08H-ML2	R88M-K75030(H/T)-□	R88M-KH75030(H/T)-□	
			R88D-KN10H-ML2	R88M-K1K020(H/T)-□	-	
			1.0 kW	R88D-KN15H-ML2	R88M-K1K030(H/T)-□	-
					R88M-K1K530(H/T)-□	-
					R88M-K1K520(H/T)-□	-
			3 phase 400 VAC	600 W	R88D-KN06F-ML2	R88M-K40020(F/C)-□
		R88M-K60020(F/C)-□			-	
	R88D-KN10F-ML2	R88M-K75030(F/C)-□			-	
	1.0 kW	R88D-KN15F-ML2		R88M-K1K020(F/C)-□	R88M-KH1K020(F/C)-□	
				R88M-K1K030(F/C)-□	-	
				R88M-K1K530(F/C)-□	-	
	1.5 kW	R88D-KN20F-ML2		R88M-K1K520(F/C)-□	R88M-KH1K520(F/C)-□	
				R88M-K90010(F/C)-□	-	
				R88M-K2K030(F/C)-□	-	
	2.0 kW	R88D-KN30F-ML2	R88M-K2K020(F/C)-□	R88M-KH2K020(F/C)-□		
R88M-K3K030(F/C)-□			-			
R88M-K3K020(F/C)-□			R88M-KH3K020(F/C)-□			
3.0 kW	R88D-KN50F-ML2	R88M-K2K010(F/C)-□	-			
		R88M-K4K030(F/C)-□	-			
		R88M-K5K030(F/C)-□	-			
5.0 kW	R88D-KN50F-ML2	R88M-K4K020(F/C)-□	R88M-KH4K020(F/C)-□			
		R88M-K5K020(F/C)-□	R88M-KH5K020(F/C)-□			
		R88M-K4K510C-□	-			
		R88M-K3K010(F/C)-□	-			

Control cables (CN1)

Symbol	Description	Connect to	Model
④	I/O connector kit (26 pins)	For I/O general purpose	- R88A-CNW01C
⑤	I/O signals cable		1 m R88A-CPKB001S-E 2 m R88A-CPKB002S-E
⑥	Terminal block cable	For I/O general purpose	1 m XW2Z-100J-B34 2 m XW2Z-200J-B34
⑦	Terminal block (M3 screw and for pin terminals) Terminal block (M3.5 screw and for fork/round terminals) Terminal block (M3 screw and for fork/round terminals)		- XW2B-20G4 - XW2B-20G5 - XW2D-20G6

External encoder cable (CN4)

Symbol	Name	Length	Model
⑧	External encoder cable	5 m	R88A-CRKM005SR-E
		10 m	R88A-CRKM010SR-E
		20 m	R88A-CRKM020SR-E

Analog monitor (CN5)

Symbol	Name	Length	Model
⑨	Analog monitor cable	1 m	R88A-CMK001S

MECHATROLINK-II cables (CN6)

Symbol	Specifications	Length	Model
⑩	MECHATROLINK-II Terminator resistor	-	JEPMC-W6022-E
	MECHATROLINK-II cables	0.5 m	JEPMC-W6003-A5-E
		1 m	JEPMC-W6003-01-E
		3 m	JEPMC-W6003-03-E
		5 m	JEPMC-W6003-05-E
		10 m	JEPMC-W6003-10-E
		20 m	JEPMC-W6003-20-E
		30 m	JEPMC-W6003-30-E

MECHATROLINK-II Motion controllers

Symbol	Name	Model		
⑪	Trajexia stand-alone	Motion control unit	TJ2-MC64 (64 axes) TJ1-MC16 (16 axes) TJ1-MC04 (4 axes)	
		ML2 master unit	TJ1-ML16 (16 axes) TJ1-ML04 (4 axes)	
			Trajexia-PLC motion controller	CJ1W-MCH72 (30 axes) CJ1W-MC472 (4 axes)
		Position Controller Unit for CJ1 PLC	CJ1W-NCF71 (16 axes) CJ1W-NC471 (4 axes) CJ1W-NC271 (2 axes)	
			Position Controller Unit for CS1 PLC	CS1W-NCF71 (16 axes) CS1W-NC471 (4 axes) CS1W-NC271 (2 axes)

Filters

Symbol	Applicable servodrive	Filter model	Manufacturer	Rated current	Leakage current	Rated voltage
⑮	R88D-KN01H-ML2, R88D-KN02H-ML2	R88A-FIK102-RE	Rasmi Electronics Ltd	2.4 A	3.5 mA	250 VAC single-phase
	R88D-KN04H-ML2	R88A-FIK104-RE		4.1 A	3.5 mA	
	R88D-KN08H-ML2	R88A-FIK107-RE		6.6 A	3.5 mA	
	R88D-KN10H-ML2, R88D-KN15H-ML2	R88A-FIK114-RE		14.2 A	3.5 mA	400 VAC three-phase
	R88D-KN06F-ML2, R88D-KN10F-ML2, R88D-KN15F-ML2	R88A-FIK304-RE		4 A	0.3 mA/32 mA ^{*1}	
	R88D-KN20F-ML2	R88A-FIK306-RE		6 A	0.3 mA/32 mA ^{*1}	
	R88D-KN30F-ML2, R88D-KN50F-ML2	R88A-FIK312-RE		12.1 A	0.3 mA/32 mA ^{*1}	

*1 Momentary peak leakage current for the filter at switch-on/off.

Connectors

Specifications	Model
External encoder connector (for CN4)	R88A-CNK41L
Safety I/O signal connector (for CN8)	R88A-CNK81S

Computer software

Specifications	Model
CX-Drive version 1.91 or higher	CX-DRIVE 1.91
CX-One software package including CX-Drive 1.91 or higher	CX-ONE

Ordering information

Accurax G5 series Analog/pulse reference configuration

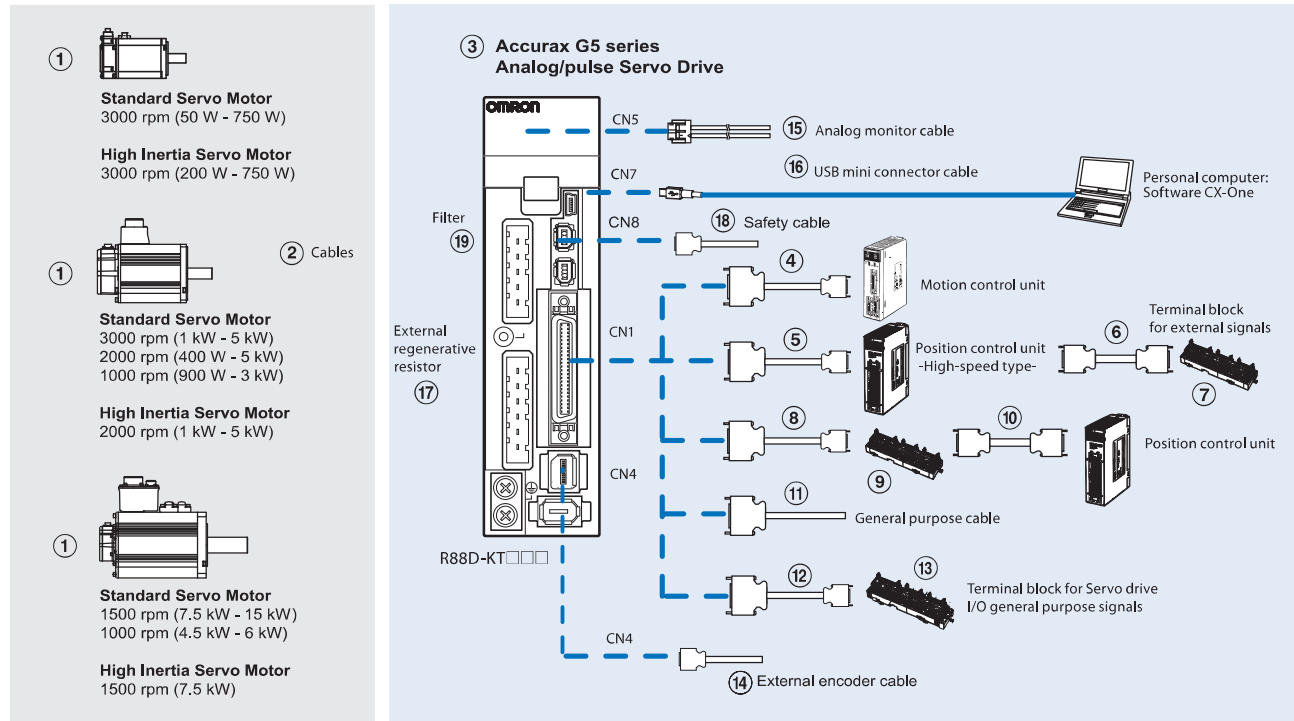

Note: The symbols ①②③④⑤... show the recommended sequence to select the components in Accurax G5 servo system

Servo motors, power & encoder cables

Note: ①② Refer to the Accurax G5 servo motor chapter for servomotor, motor cables or connectors selection

Servo drives

Symbol	Specifications		Servo drive models ^{*1}	① Compatible Accurax G5 series rotary servo motors	
				Standard models	High inertia models
③	1 phase 230 VAC	100 W	R88D-KT01H	R88M-K05030(H/T)-□	-
		200 W	R88D-KT02H	R88M-K10030(H/T)-□	-
		400 W	R88D-KT04H	R88M-K20030(H/T)-□	R88M-KH20030(H/T)-□
		750 W	R88D-KT08H	R88M-K40030(H/T)-□	R88M-KH40030(H/T)-□
		1.0 kW	R88D-KT10H	R88M-K75030(H/T)-□	R88M-KH75030(H/T)-□
		1.5 kW	R88D-KT15H	R88M-K1K020(H/T)-□	-
	3 phase 400 VAC	600 W	R88D-KT06F	R88M-K1K030(H/T)-□	-
		1.0 kW	R88D-KT10F	R88M-K40020(F/C)-□	-
				R88M-K60020(F/C)-□	-
				R88M-K75030(F/C)-□	-
		1.5 kW	R88D-KT15F	R88M-K1K020(F/C)-□	R88M-KH1K020(F/C)-□
				R88M-K1K030(F/C)-□	-
				R88M-K1K530(F/C)-□	-
				R88M-K1K520(F/C)-□	R88M-KH1K520(F/C)-□
		2.0 kW	R88D-KT20F	R88M-K90010(F/C)-□	-
				R88M-K2K030(F/C)-□	-
				R88M-K2K020(F/C)-□	R88M-KH2K020(F/C)-□
				R88M-K3K030(F/C)-□	-
				R88M-K3K020(F/C)-□	R88M-KH3K020(F/C)-□
3.0 kW	R88D-KT30F	R88M-K2K010(F/C)-□	-		
		R88M-K4K030(F/C)-□	-		
		R88M-K5K030(F/C)-□	-		
		R88M-K4K020(F/C)-□	R88M-KH4K020(F/C)-□		
		R88M-K5K020(F/C)-□	R88M-KH5K020(F/C)-□		
		R88M-K4K510C-□	-		
5.0 kW	R88D-KT50F	R88M-K3K010(F/C)-□	-		
		R88M-K6K010C-□	-		
		R88M-K7K515C-□	R88M-KH7K515C-□		
		R88M-K11K015C-□	-		
7.5 kW	R88D-KT75F	R88M-K15K015C-□	-		
15 kW	R88D-KT150F				

*1 Drive Programming – embedded indexer functionality – is available in the Accurax G5 Analogue/pulse models with firmware 1.10 or higher.

Control cables (CN1)

Symbol	Description	Connect to		Model	
④	Control cable (1 axis)	Motion control units CS1W-MC221 CS1W-MC421	1 m	R88A-CPG001M1	
			2 m	R88A-CPG002M1	
			3 m	R88A-CPG003M1	
			5 m	R88A-CPG005M1	
	Control cable (2 axes)	Motion control units CS1W-MC221 CS1W-MC421	1 m	R88A-CPG001M2	
			2 m	R88A-CPG002M2	
			3 m	R88A-CPG003M2	
			5 m	R88A-CPG005M2	
⑤	Control cable (line-driver output for 1 axis)	Position control units (high-speed type) CJ1W-NC234 CJ1W-NC434	1 m	XW2Z-100J-G9	
			5 m	XW2Z-500J-G9	
			10 m	XW2Z-10MJ-G9	
	Control cable (open-collector output for 1 axis)	Position control units (high-speed type) CJ1W-NC214 CJ1W-NC414	1 m	XW2Z-100J-G13	
			3 m	XW2Z-300J-G13	
	Control cable (line-driver output for 2 axes)	Position control units (high-speed type) CJ1W-NC234 CJ1W-NC434	1 m	XW2Z-100J-G1	
			5 m	XW2Z-500J-G1	
			10 m	XW2Z-10MJ-G1	
	Control cable (open-collector output for 2 axes)	Position control units (high-speed type) CJ1W-NC214 CJ1W-NC414	1 m	XW2Z-100J-G5	
			3 m	XW2Z-300J-G5	
	⑥	Terminal block cable for external signals (for input common, forward/reverse run prohibited inputs, emergency stop input, origin proximity input and interrupt input)	Position control units (high-speed type) CJ1W-NC234 CJ1W-NC434 CJ1W-NC214 CJ1W-NC414	0.5 m	XW2Z-C50X
				1 m	XW2Z-100X
2 m				XW2Z-200X	
3 m				XW2Z-300X	
5 m				XW2Z-500X	
10 m				XW2Z-010X	
⑦				Terminal block for external signals (M3 screw, pin terminals)	
	Terminal block for ext. signals (M3.5 screw, fork/round terminals)		–	XW2B-20G5	
	Terminal block for ext. signals (M3 screw, fork/round terminals)		–	XW2D-20G6	
⑧	Cable from servo relay unit to servo drive	CS1W-NC1□3, CJ1W-NC1□3, C200HW-NC113, CS1W-NC2□3/4□3, CJ1W-NC2□3/4□3, C200HW-NC213/413, CQM1H-PLB21 or CQM1-CPU43 CJ1M-CPU21/22/23	1 m	XW2Z-100J-B25	
			2 m	XW2Z-200J-B25	
			1 m	XW2Z-100J-B31	
			2 m	XW2Z-200J-B31	
⑨	Servo relay unit	Position control units CS1W-NC1□3, CJ1W-NC1□3 or C200HW-NC113	–	XW2B-20J6-1B (1 axis)	
			–	XW2B-40J6-2B (2 axes)	
		Position control units CS1W-NC2□3/4□3, CJ1W-NC2□3/4□3 or C200HW-NC213/413	–	XW2B-20J6-3B (1 axis)	
			–	XW2B-20J6-8A (1 axis)	
		CQM1H-PLB21 or CQM1-CPU43 CJ1M-CPU21/22/23	–	XW2B-40J6-9A (2 axes)	
			–	XW2B-40J6-9A (2 axes)	
⑩	Position control unit connecting cable	CQM1H-PLB21 CS1W-NC113 or C200HW-NC113 CS1W-NC213/413 or C200HW-NC213/413 CS1W-NC133 CS1W-NC233/433 CJ1W-NC113 CJ1W-NC213/413 CJ1W-NC133 CJ1W-NC233/433 CJ1M-CPU21/22/23	0.5 m	XW2Z-050J-A3	
			1 m	XW2Z-100J-A3	
			0.5 m	XW2Z-050J-A6	
			1 m	XW2Z-100J-A6	
			0.5 m	XW2Z-050J-A7	
			1 m	XW2Z-100J-A7	
			0.5 m	XW2Z-050J-A10	
			1 m	XW2Z-100J-A10	
			0.5 m	XW2Z-050J-A11	
			1 m	XW2Z-100J-A11	
			0.5 m	XW2Z-050J-A14	
			1 m	XW2Z-100J-A14	
			0.5 m	XW2Z-050J-A15	
			1 m	XW2Z-100J-A15	
			0.5 m	XW2Z-050J-A18	
			1 m	XW2Z-100J-A18	
0.5 m	XW2Z-050J-A19				
1 m	XW2Z-100J-A19				
0.5 m	XW2Z-050J-A33				
1 m	XW2Z-100J-A33				
⑪	General purpose cable	For general purpose controllers	1 m	R88A-CPG001S	
			2 m	R88A-CPG002S	
⑫	Terminal block cable	For general purpose controllers	1 m	XW2Z-100J-B24	
			2 m	XW2Z-200J-B24	
⑬	Terminal block (M3 screw and for pin terminals)		–	XW2B-50G4	
	Terminal block (M3.5 screw and for fork/round terminals)		–	XW2B-50G5	
	Terminal block (M3 screw and for fork/round terminals)		–	XW2D-50G6	
	Terminal block (M3 screw and for fork/round terminals)		–	XW2D-50G6	

External encoder cable (CN4)

Symbol	Name		Model
⑭	External encoder cable	5 m	R88A-CRKM005SR-E
		10 m	R88A-CRKM010SR-E
		20 m	R88A-CRKM020SR-E

Analog monitor (CN5)

Symbol	Name		Model
⑮	Analog monitor cable	1 m	R88A-CMK001S

USB personal computer cable (CN7)

Symbol	Name		Model
⑯	USB mini-connector cable	2 m	AX-CUSBM002-E

External regenerative resistor

Symbol	Regenerative resistor unit model	Specifications
⑰	R88A-RR08050S	50 Ω, 80 W
	R88A-RR080100S	100 Ω, 80 W
	R88A-RR22047S	47 Ω, 220 W
	R88A-RR50020S	20 Ω, 500 W

Cable for Safety Functions (CN8)

Symbol	Description	Model
⑱	Safety connector with 3 m cable (with loose wires at one end)	R88A-CSK003S-E

Filters

Symbol	Applicable servodrive	Filter model	Manufacturer	Rated current	Leakage current	Rated voltage	
⑲	R88D-KT01H, R88D-KT02H	R88A-FIK102-RE	Rasmi Electronics Ltd	2.4 A	3.5 mA	250 VAC single-phase	
	R88D-KT04H	R88A-FIK104-RE		4.1 A	3.5 mA		
	R88D-KT08H	R88A-FIK107-RE		6.6 A	3.5 mA		
	R88D-KT10H, R88D-KT15H	R88A-FIK114-RE			14.2 A	3.5 mA	400 VAC three-phase
	R88D-KT06F, R88D-KT10F, R88D-KT15F	R88A-FIK304-RE			4 A	0.3 mA / 32 mA ^{*1}	
	R88D-KT20F	R88A-FIK306-RE			6 A	0.3 mA / 32 mA ^{*1}	
	R88D-KT30F, R88D-KT50F	R88A-FIK312-RE			12.1 A	0.3 mA / 32 mA ^{*1}	
	R88D-KT75F	R88A-FIK330-RE			22 A	0.3 mA / 40 mA ^{*1}	
	R88D-KT150F	R88A-FIK350-RE			44 A	2 mA / 130 mA ^{*1}	

*1 Momentary peak leakage current for the filter at switch-on/off.

Connectors

Specifications	Model
I/O connector kit -50 pins-(for CN1)	R88A-CNU11C
External encoder connector (for CN4)	R88A-CNK41L
Safety I/O signal connector (for CN8)	R88A-CNK81S

Computer software

Specifications	Model
CX-Drive version 2.10 or higher	CX-DRIVE 2.10
CX-One software packaging including CX-Drive 2.10 or higher	CX-ONE

ALL DIMENSIONS SHOWN ARE IN MILLIMETERS.
To convert millimeters into inches, multiply by 0.03937. To convert grams into ounces, multiply by 0.03527.