

WIM45-UNTL-LIU5X2-0.3-PSG4M

Linear Position Sensor – For Analog Monitoring of Pneumatic Cylinders

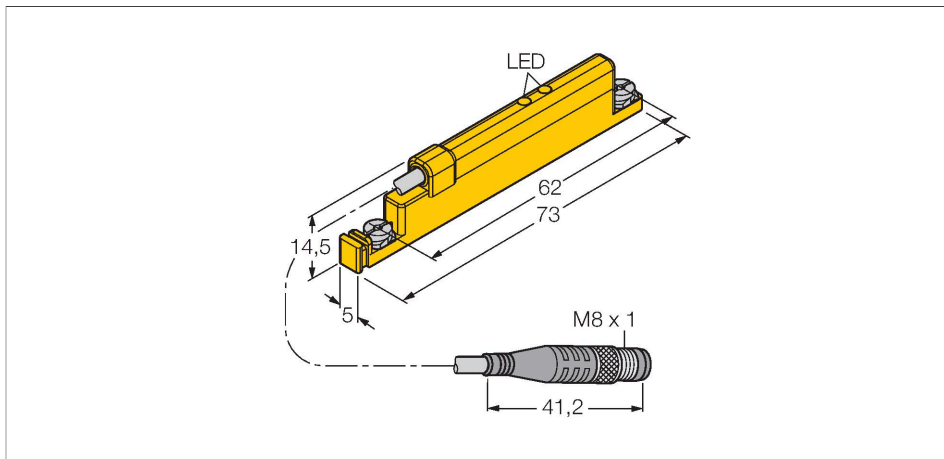

Features

- Plastic, PA12-GF30
- For direct mounting on pneumatic T-groove cylinders
- Magnetic field status displayed via two LEDs
- Measured value storage
- Hardly affected by external magnetic fields
- 4-wire, 15...30 VDC
- 0...10 V and 4...20 mA
- Pigtail with male end, M8 x 1

Wiring diagram

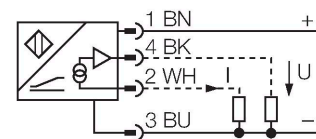

Technical data

Type	WIM45-UNTL-LIU5X2-0.3-PSG4M
ID	1536620
Measuring principle	Magnetic
General data	
Measuring range	45 mm
Resolution	10 bit
Repeatability	≤ 0.1% of measuring range IA - BI
	with non-rotatable piston rod
Reproducibility	≤ 45 μm
Linearity deviation	≤ 1 %
Temperature drift	≤ ± 0.006 % / K
Electrical data	
Operating voltage	15...30 VDC
Residual ripple	≤ 10 % U _{ss}
No-load current	15 mA
Isolation test voltage	≤ 0.5 kV
Short-circuit protection	yes
Wire breakage/Reverse polarity protection	yes / Complete
Output function	4-wire, Analog output
Voltage output	0...10 V
Current output	4...20 mA
Load resistance voltage output	≥ 4.7 kΩ
Load resistance current output	≤ 0.4 kΩ

Functional principle

Magnetic inductive linear position sensors with analog output accomplish control tasks by providing a signal proportional to the position of the piston rod. The polarity of the magnet has no effect on the output signal. The outstanding features of these robust sensors are excellent repeatability, resolution and linearity, excellent electromagnetic capability and a broad temperature range.

Technical data

Mechanical data	
Design	UNTL
Dimensions	73 x 5 x 14.5 mm
Housing material	Plastic, PA12-GF30
Tightening torque fixing screw	0.4 Nm
Electrical connection	Cable with connector, M8 × 1
Cable quality	0.3 m
Environmental conditions	
Ambient temperature	-25...+70 °C
Vibration resistance	55 Hz (1 mm)
Shock resistance	30 g (11 ms)
Protection class	IP67
Display magnetic-field status	2x LED, yellow

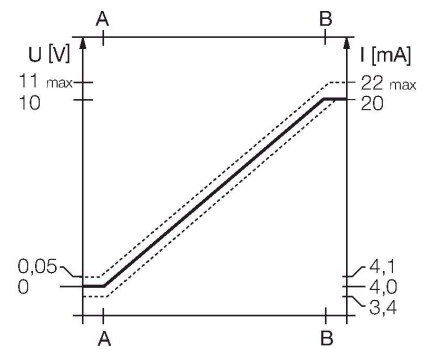

Mounting instructions

Mounting instructions/Description

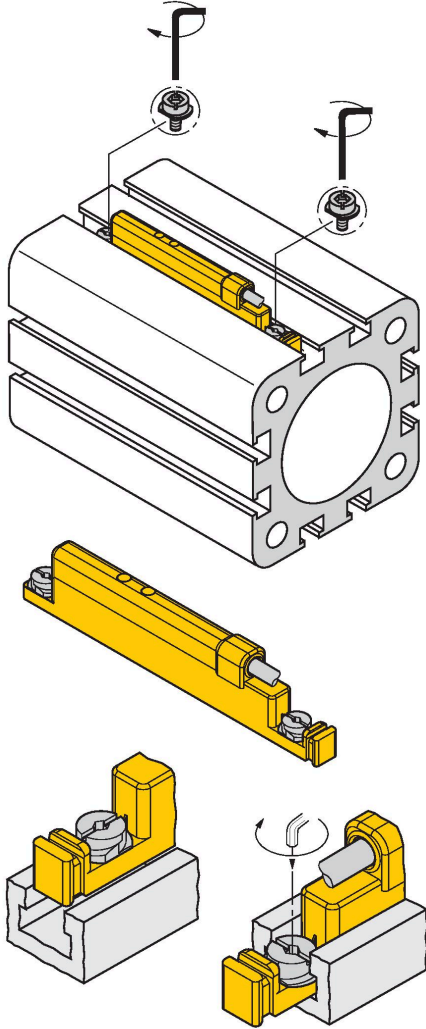

Thanks to the mounting lip, the sensor can be inserted into the groove from above with one hand. The sensor is mounted as follows: Turn the screw clockwise. The sensor is pressed down and thus locked. A quarter turn of the screw with a slotted screwdriver (blade thickness 0.5 mm) or 1.5 mm Allen key is sufficient to fasten the sensor so that it doesn't vibrate. A tightening torque of 0.4 Nm is sufficient for secure mounting without damaging the cylinder. A cable clip is included in the scope of delivery. It enables smooth cable routing in the groove and ensures that the cable is fastened as securely as possible. The corresponding accessories for mounting on other cylindrical housings must be ordered separately.

LEDs:

If both LEDs are on, the magnet is in the measuring range of the sensor and the magnetic field has optional magnetizing force; accuracy and linearity of the output curve are within the specified range.

If only one LED is on, the magnet is within the measuring range, but the magnetizing force is not ideal; the output characteristic may be outside the specified range.

If both LEDs are off, no magnet is in the measuring range of the sensor.