

Mist Spray Unit

LMU100/200 Series

- Intermittent spray to cutting and press gear chains, etc.



LMU100

Control Circuit

LMU100-□□

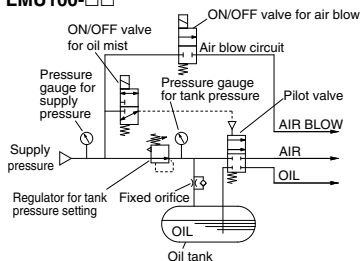

LMU200-□□

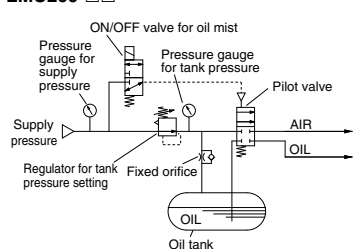

Standard Specifications

Model	LMU100	LMU200
Inlet air pressure	0.1 to 1.0 MPa	
Oil tank set pressure range	0.05 to 0.2 MPa	
Oil	Turbine oil, Non-water soluble cutting oil (JIS, N1 type)	
Dynamic viscosity of oil (40°C)	2 to 200 mm ² /s	
Oil tank capacity (cm ³)	Total capacity: 3000	
Ambient and fluid temperature	Effective capacity: 2500	
Solenoid valve voltage	5 to 50°C	
	100 VAC 50/60Hz, 200 VAC 50/60Hz, 24 VDC	
Port size	SUP	Rc 1/4
	OUT	3 x Rc 1/4
Weight (kgf)	AIR	: T0604 (ø6 tube) applicable
	OIL	: T0425 (ø4 tube) applicable
	AIR BLOW	: T0806 (ø8 tube) applicable
	8.4	7.9

How to Order

LMU 1 00-1 3

Mist spray unit

Air blow circuit

Float switch

1	Available
2	Not available
Rated voltage	
1	100 VAC (50/60 Hz)
2	200 VAC (50/60 Hz)
5	24 VDC

0	None
3	For the upper and lower limit control (SW turns OFF when the float is on the upper side. SW turns ON when the float goes down. Contact capacity 50 VA AC, 50 W DC)

Recommended Equipment

It is recommended to use each mist spray unit type with the mixing valves, magnet holders, branch pipes and nylon tubes listed in the table below.

Mist spray unit	Mixing valve	Magnet holder	Branch pipe	Nylon tube
This unit, with an oil tank and a spray ON/OFF control unit, sends oil and air to the mixing valve.	This valve adjusts the amounts of oil and air from the mist spray unit using built-in oil and air needles, and also discharges oil mist from the nozzle.	This magnet holder enables the mixing valve installed on the arm end to be freely attached to the iron and steel parts such as machining tools, etc.	This pipe is used to separate oil and air from the mist spray unit when using several mixing valves.	This tube is used for the air piping and oil piping between the mist spray unit and the mixing valve.
LMU100-□□	LMV110-□□ LMV120-□□	LMH10	LMD1-□	OIL→T0425□ AIR→T0604□ AIR BLOW→T0806□
LMU200-□□	LMV210-□□ LMV220-□□	LMH20	LMD2-□	OIL→T0425□ AIR→T0604□

Application Examples

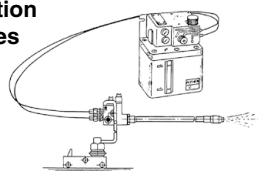

Standing type machining center (Drilling center)

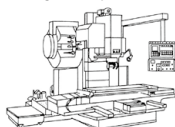

Horizontal machining center

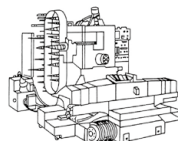

LMU100/200 Series

Construction/Working Principle

LMU100-□□

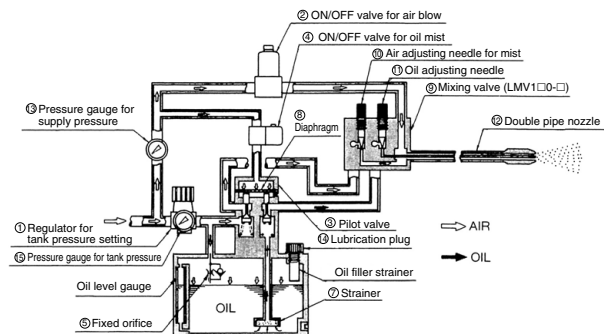

LMU200-□□

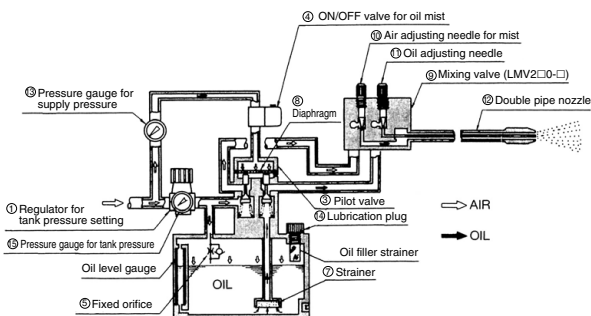

Working Principle

Of the compressed air from the air source, part is directed to the regulator for tank pressure setting (1), while the rest is directed to the ON/OFF valve for oil mist (4), which operates the ON/OFF valve for the air blow circuit (2) and the pilot valve for the mixing circuit (3). Compressed air at a prescribed setting determined by the regulator for tank pressure setting (1) passes through the fixed orifice (5) and gradually fills the oil tank (6), applying pressure to the OIL surface. The OIL in the tank passes through the strainer (7) and is drawn into the pilot valve (3). Operating the ON/OFF valve for oil mist (4) at this point will cause operating signal pressure to be conducted into the pilot valve (3), pushing the diaphragm (8) downwards, and as a result the compressed air from pilot valve (3) and oil from the opened valve will flow through their respective conduits and be drawn into the mixing valve (9).

Air and oil are adjusted with varying quantities by the air for mist from the mixing valve (9) and oil adjustment needles (10) and (11). With dual piping from the mixing valve (9) to the dual pipe nozzle (12), compressed air passes through the outside while oil passes through the inside, and at the tip of the dual pipe nozzle (12) they are sprayed out as a fine mist by the discharged air.

To remove cutting chips, operate the ON/OFF valve for air blow (2), which will cause the supplied compressed air to be drawn directly into the mixing valve (9) and blown out as air through the external piping of the dual pipe nozzle (12). To replenish oil, loosen the oil supply plug (14) to discharge the compressed air from inside the tank through the oil supply plug's side hole. Since it flows gradually from the fixed orifice (5) into the interior of the tank, it is easy to replenish oil from the oil supply hole.

Oil Discharge Rate (Representative Value)

Conditions Oil: Turbine oil class 1 ISO VG32
 Oil temperature: 26°C

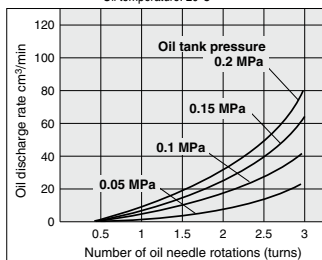

Air flow rate (Representative Value)

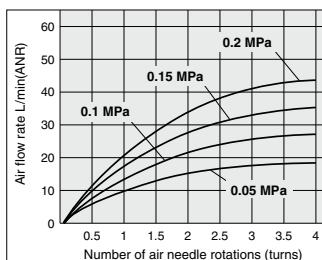

Handling Precautions

Mounting

- Be sure to mount an air filter corresponding to 5mm (equivalent to the SMC AF20) on the SUP side of the mist spray unit.

Adjustment

- After loosening the tank's pressure-setting knob (by rotating it to the left), introduce air from the air source. Use the tank's pressure-setting knob and set the range from 0.05 to 0.2 MPa, set each control valve to ON (manual operation or energized), and inspect carefully to make sure there is no looseness in the fittings at each connecting point. At this time, be sure the air and oil adjustment needles of the mixing valve are in a completely closed position (by rotating it to the right.)

Lubrication

- Completely release air in the OIL pipe. Even small amounts of air in the OIL pipe will cause oil to dribble. Fully open the oil adjustment needle of the mixing valve, and turn the ON/OFF valve for oil mist generation to the ON position, or press and hold down the manual button to release all air from inside the OIL pipe. If air build-up from use of branching pipes, etc. takes place inside the OIL pipe, mount an air release valve at the highest position and let the air out. Be sure to carry out this operation when replenishing the oil after the oil tank becomes empty.

Dimensions/Parts List

LMU100

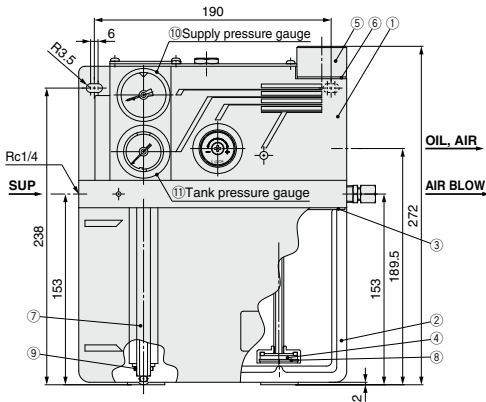
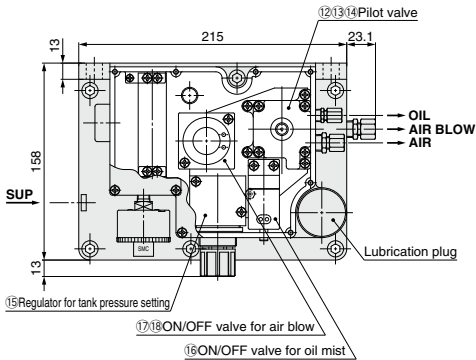

LMU200

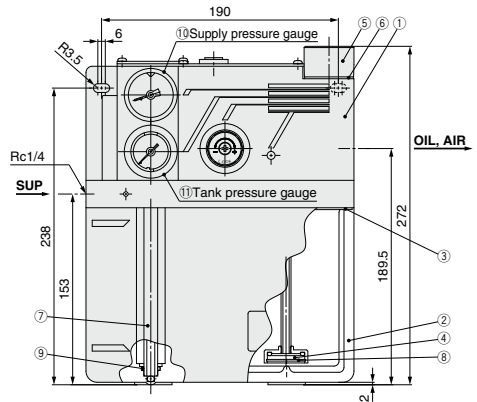
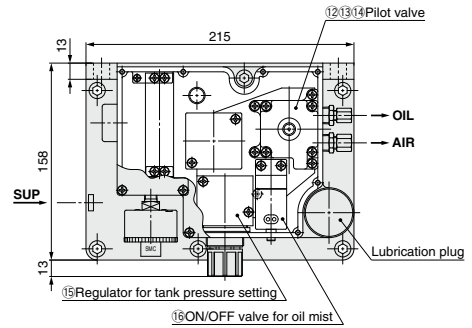

AL800
AL900
ALF
ALT
ALD
ALB
LMU
ALIP
AEP
HEP

Main Parts List

No.	Description	Material	Note
1	Mist spray body	Aluminum die-casted	Platinum silver coated
2	Mist spray tank	Aluminum die-casted	Platinum silver coated

Spare Parts/Replacement Parts Part No.

No.	Description	Material	Qty.	Part no.	
				LMU100	LMU200
3	Body seal	NBR	1	81021-3	
4	Element	Bronze	1	81021-6	
5	Lubrication plug	Brass	1	81021-7	
6	Filler seal	—	1	81021-8	
7	Level gauge	Hard glass	1	81021-9	
8	Type C retaining ring for hole	Stainless steel	1	FG00193	
9	O-ring	FKM	2	KA00622	
10	Pressure gauge	—	1	G46-10-01	
11	Pressure gauge	—	1	G46-4-01-L	
12	Pilot valve	—	1	81022P	
13	O-ring	NBR	1	KA00078	
14	O-ring	FKM	2	KA00099	
15	Regulator	—	1	INA-13-717	
16	Solenoid valve	—	1	VO307K- $\frac{1}{2}$ G1-X328	
17	Solenoid valve	—	1	VO315-003G	
18	O-ring	NBR	4	KA00087	

LMU100/200 Series Related Products

Mixing Valve: LMV Series

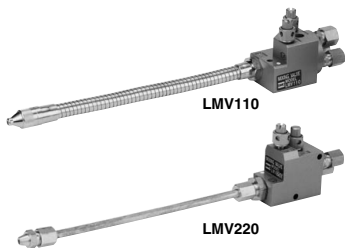

Specifications

Inlet air pressure		0.3 MPa Max.
Ambient and fluid temperature		5 to 60°C
Port size	AIR	T0604 (ø6 tube) applicable
	OIL	T0425 (ø4 tube) applicable
	AIR BLOW	T0806 (ø8 tube) applicable

How to Order

LMV 1 1 0-20

• Mixing valve	1 Available 2 Not available	• Air blow circuit	1 Flexible tubing 2 Copper tubing	• Nozzle tubing length: L	20 200 mm 25 250 mm 30 300 mm 35 350 mm
----------------	--------------------------------	--------------------	--------------------------------------	---------------------------	--

Construction

LMV1□0/With air blow circuit

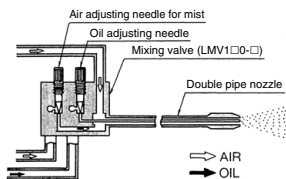

LMV2□0/Without air blow circuit

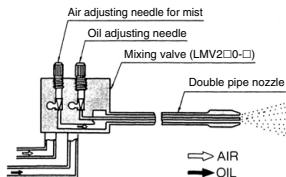

Dimensions

LMV1□0-□

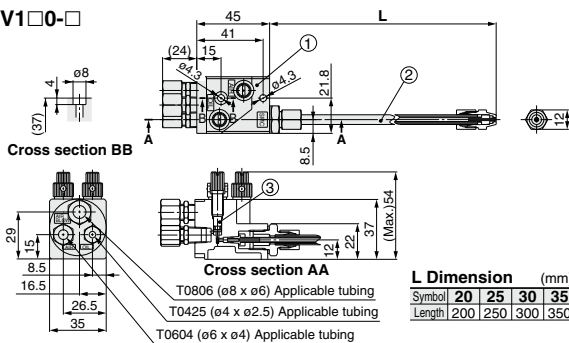

L Dimension (mm)				
Symbol	20	25	30	35
Length	200	250	300	350

LMV2□0-□

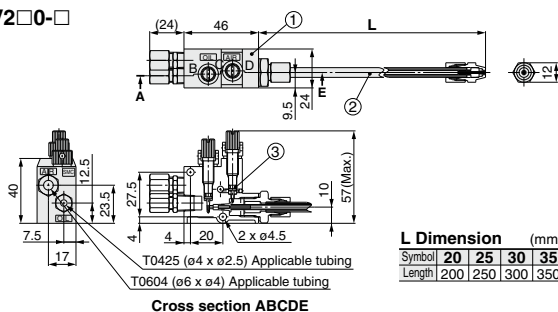

L Dimension (mm)				
Symbol	20	25	30	35
Length	200	250	300	350

Main Parts List

No.	Description	Material	Note
1	Mixing valve body	Aluminum die-casted	Platinum silver coated

Spare Parts/Replacement Parts Part No.

No.	Description	Material	Qty.	Part no.	
				LMV□10	LMV□20
2	Flexible nozzle assembly	—	1	81023-2A-1 to 4 (Note 1)	—
2	Copper piping nozzle assembly	—	1	—	81023-31A-1 to 4 (Note 1)
3	O-ring	FKM	2	123116-2	

Note 1) Numbers indicate nozzle lengths. -1: 200 mm, -2: 250 mm, -3: 300 mm, -4: 350 mm

