

SPECIFICATIONS

CONTACT CARRIER MATERIAL	NYLON or PBT
CONTACT MATERIAL/PLATING	BRASS/GOLD
CONNECTOR HOUSING MATERIAL/PLATING	BRASS/NICKEL
O-RING GASKET MATERIAL	RUBBER (NITRILE OR FPM)
RATED CURRENT [A]	6.0 A
RATED VOLTAGE [V]	300 V
CONDUCTOR INSULATION MATERIAL	PVC
NUMBER OF CONDUCTORS (AWG)	11x18 AWG
PROTECTION CLASS	MEETS IEC IP67
TEMPERATURE RANGE	-40°C TO +105°C (-40°F TO +221°F)
MAXIMUM PANEL THICKNESS	3.5 [0.138]

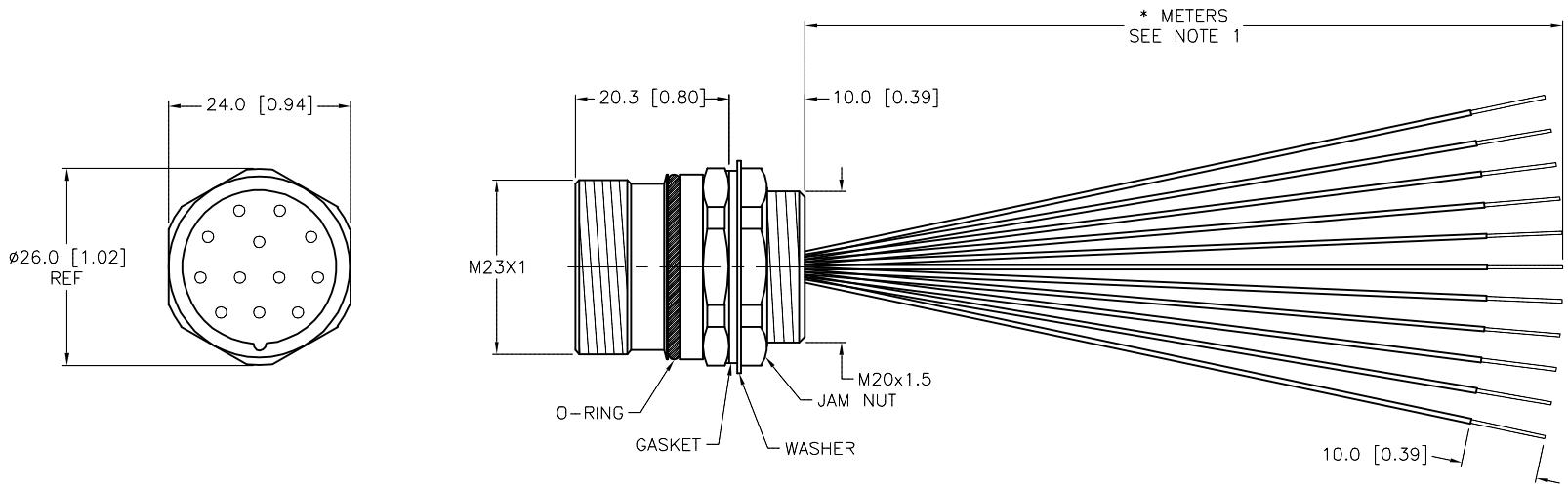

CABLE LENGTH	TOLERANCE*
ALL LENGTHS	+ 4% (OR 50mm) OF LENGTH - 0% (OR 0mm) OF LENGTH WHICHEVER IS GREATER
STRIP LENGTH	TOLERANCE*
0-7mm	±0.5mm
8-29mm	±1.0mm
30-49mm	±2.0mm
50-69mm	±3.0mm
70-100mm	±4.0mm
OVER 100mm	±5.0mm

* UNLESS OTHERWISE SPECIFIED

NOTES:
 1. "*" INDICATES LEAD LENGTH IN METERS. CONTACT TURCK TO ORDER SPECIFIC LENGTHS.

SOURCE DRAWING - FOR REFERENCE ONLY

RELATED DOCUMENTS 1. 2. 3. 4.	3RD ANGLE PROJECTION 	THIS DRAWING IS CONFIDENTIAL AND THE PROPERTY OF TURCK INC. USE OF THIS DOCUMENT WITHOUT WRITTEN PERMISSION IS PROHIBITED.		3000 CAMPUS DRIVE MINNEAPOLIS, MN 55441 1-800-544-7769 (763) 553-7300 (763) 553-0708 fax www.turck.us	
		DRFT	RDS	DATE	10/30/07
MATERIAL SEE SPECIFICATIONS	ALL DIMENSIONS DISPLAYED ON THIS DRAWING ARE FOR REFERENCE ONLY	APVD		SCALE	1=1.0
FINISH SEE SPECIFICATIONS		CONTACT TURCK FOR MORE INFORMATION	UNIT OF MEASUREMENT MILLIMETER [INCH]		IDENTIFICATION NO.
C	RUBBER (NITRILE OR FPM)	ER	11/19/19	75412	
REV	DESCRIPTION	BY	DATE	ECO NO.	

DO NOT SCALE THIS DRAWING

FILE: 777009443

SHEET 1 OF 1